

*The*  
***MultiGen Creator***  
*Desktop Tutor*

*Version 2.6 for Windows® and IRIX*



**MultiGen-Paradigm**  
VISUALIZE REALITY





# Legal Stuff

## MultiGen-Paradigm, Inc. Creator Desktop Tutor Version 2.6

©2002 MultiGen-Paradigm, Inc., a subsidiary of Computer Associates International, Inc. (“Computer Associates”). All trademarks, trade names, service marks and logos referenced herein belong to their respective companies. All rights reserved.

MultiGen-Paradigm, Inc. (MultiGen-Paradigm) PROVIDES THIS MATERIAL AS IS, WITHOUT WARRANTY OF ANY KIND, EITHER EXPRESSED OR IMPLIED, INCLUDING BUT NOT LIMITED TO, THE IMPLIED WARRANTIES OF MERCHANTABILITY AND FITNESS FOR A PARTICULAR PURPOSE.

MultiGen-Paradigm, Inc. may make improvements and changes to the product described in this document at any time without notice. MultiGen-Paradigm assumes no responsibility for the use of the product or this document except as expressly set forth in the applicable MultiGen-Paradigm agreement or agreements and subject to terms and conditions set forth therein and applicable MultiGen-Paradigm policies and procedures. This document may contain technical inaccuracies or typographical errors. Periodic changes may be made to the information contained herein. If necessary, these changes will be incorporated in new editions of the document.

MultiGen-Paradigm, Inc. is the owner of all intellectual property rights in and to this document and any proprietary software that accompanies this documentation, including but not limited to, copyrights in and to this document and any derivative works therefrom. Use of this document is subject to the terms and conditions of the MultiGen-Paradigm Software License Agreement included with this product.

No part of this publication may be stored in a data retrieval system, transmitted, distributed or reproduced, in whole or in part, in any way, including, but not limited to, photocopy, photograph, magnetic, or other record, without the prior written permission of MultiGen-Paradigm, Inc.

Use, duplication, or disclosure by the government is subject to restrictions set forth in subparagraph (c)(1)(ii) of the Rights in Technical Data and Computer Software clause and DFARS 52.227-7013 and in similar clauses in the FAR and NASA FAR Supplement.

Printed in Canada  
Part Number: 03-0295  
April 15, 2003



# Introduction

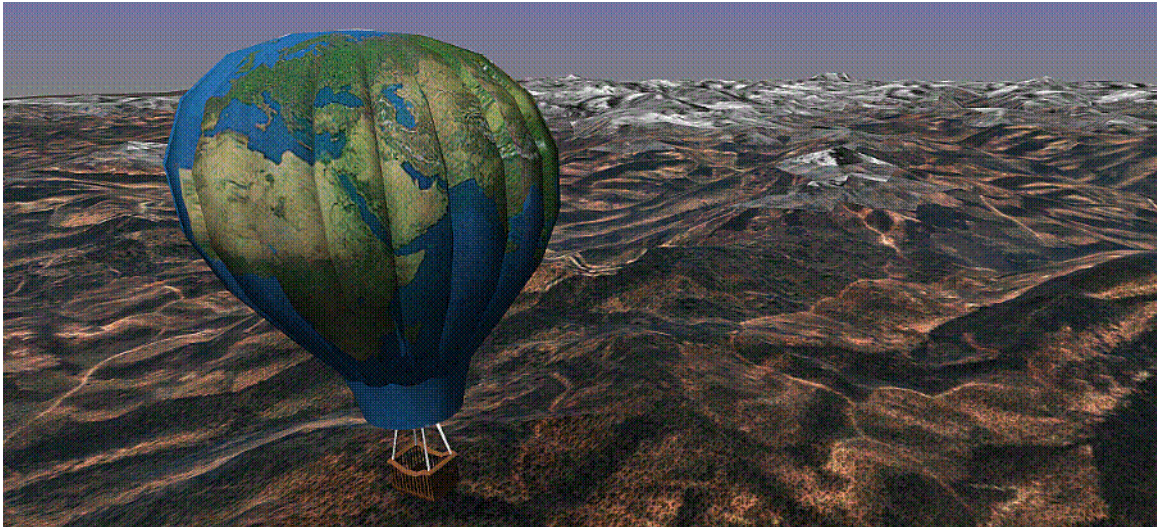

This book is a practical, hands-on guide to mastering the fundamentals of MultiGen Creator. With this booklet, you will quickly learn how to use the various tools and features of Creator to build your realtime models, articulate, shade, and texture your models, and build the world in which to place your models.

You will also find interesting tips on the strategy of model construction that work the first time.

We recommend you work through the chapters in sequence. The chapters in this booklet are organized in production order, reflecting the order of topics you are likely to encounter when making models. With this structure, the booklet also serves as a handy, topically oriented reference.

Upon completing the material in this book, you should be able to:

- **Apply good realtime modeling practices**
- **Import OpenFlight and other data formats for cleanup or extended modeling**
- **Effectively apply all of the core modeling tools to construct, prototype, and optimize realtime models**
- **Construct a solidly structured model database**
- **Add special characteristics to your data structure: Degrees of Freedom, Levels of Detail**
- **Apply lighting, materials, textures to your model or modeled world**
- **Export model data to realtime systems for interactive use**

## What's Ahead



This book assumes you will quickly learn (and have more fun) if you actually *do* something with MultiGen Creator, so:

- Please install MultiGen Creator and use the software as you read through the book.
- To get the tutorial directories and files for the Windows platform, select Custom installation, and select the Tutorial Files option. The tutorial directories and files are automatically installed on the IRIX platform. As an alternative on Windows, you can drag the Tutorial\_Files folder directly from the CD to your MultiGen folder.
- Completed versions of the models constructed in this tutorial are also in the *Program Files\Multigen-Paradigm\resources\tutorials\creator\DesktopTutor\Models* folder, making it easy to jump into any section or check the results of your work.
- For reference, this document is in PDF form (*Tutor.pdf*) in the *Program Files\Multigen-Paradigm\docs\creator* folder.



# Desktop Tutor Contents

---

---

<b>Chapter 1</b>		
<b>Introduction to Visual Simulation</b>	How is Realtime Authoring Different?	10
	Why is Visual Simulation so Interesting?	11
	What are the Components Used in a Visual Simulation?	12
	Can CAD Models be Used for Visual Simulation?	14
	Can I use Cool Cinematic Data?	15
	Good Practice	16
<b>Chapter 2</b>		
<b>Getting Started with MultiGen Creator</b>	The Basics	19
	Starting Creator	19
	Exiting Creator	19
	Opening a File or Creating a New One	20
	Saving Your Work	21
	Window Tour	22
	Moving Around in Your 3D World	23
	Selecting Geometry	25
	Create Your First Model	27
	Working with Color	37
<b>Chapter 3</b>		
<b>Construct Your First Realtime Model</b>	The Genesis of a Realtime Model	43
	A Classic Farmhouse	44
<b>Chapter 4</b>		
<b>Structuring a Database Hierarchy</b>	The Basics	72
	Hierarchy View	72
	Proper Database Structuring	73
	Working with the Database Structure	74
<b>Chapter 5</b>		
<b>Lighting and Shading</b>	Lighting and Shading	82
	Light Sources	87



	Light Source Palette	88
	Creating an Infinite Light Source	91
	Creating a Local Light Source	93
	Creating a Spotlight Source	96
	Interesting Options	101
<b>Chapter 6</b>		
<b>Materials</b>	Setting Material Properties	104
	Applying Materials	106
	Tutorial — The Glass Greenhouse	107
	Modeling Goal	107
	Modeling Objectives	107
	Constructing the Greenhouse	108
<b>Chapter 7</b>		
<b>Applying Textures to Your Farmhouse</b>	Texturing	114
	The Texture Palette	116
	Applying Textures to the House	121
<b>Chapter 8</b>		
<b>Constructing Vehicles</b>	Introduction	130
	Using a Polygon for a Background Image	131
	Tutorial — Modeling with the Wall Tool	132
	Modeling Goal	132
	Modeling Objectives	132
	Creating a Background Polygon	132
	Mapping the Background Texture	133
	Tutorial — Cross-Sectional Modeling	137
	Modeling Goal	137
	Modeling Objectives	137
	Mirror the Truck	143
	Making a 3D Template	145
	Bounding Volumes	147



	Types of Bounding Volumes	147
	Creating and Customizing Bounding Volumes	148
	Bounding Volume Offsets	150
<b>Chapter 9</b>		
<b>Degrees of Freedom</b>	Degree of Freedom Tools	154
	Creating and Positioning DOF Nodes	155
	Tutorial — The Crane	170
	Modeling Goal	170
	Modeling Objectives	170
	Tutorial Steps	170
<b>Chapter 10</b>		
<b>Levels of Detail</b>	Levels of Detail	177
	Modeling Goal	177
	Getting Started	179
	Isolate the Medium Farmhouse	182
	Simplifying the Low LOD	193
	Switching Distances	199
<b>Chapter 11</b>		
<b>Generating Batch Terrain With Features</b>	Creating Terrain Using Batch Processing	204
	Modeling Goal	204
	Getting Started	204
	Set up General Information	209
	Setting up Terrain	213
	Setting up Features	222
	Create a Project File	236
	Generating the Terrain	238
<b>Chapter 12</b>		
<b>Exploring TCT</b>	What is TCT?	246
	Generating a TCT Database with Culture Features	248





## *Introduction to Visual Simulation*

### Introduction

MultiGen Creator is a software package designed specifically for the creation of realtime 3D models for visual simulation. Creator makes it easy to import, structure, edit, prototype, and optimize model databases for use in both large scale visual simulations and entertainment gaming environments.

This section summarizes the essential framework of thought behind the creation of effective real-time visual simulation models.

### Contents

<b>HOW IS REALTIME AUTHORING DIFFERENT?</b>	10	<b>CAN CAD MODELS BE USED FOR VISUAL SIMULATION?</b>	14
<b>WHY IS VISUAL SIMULATION SO INTERESTING?</b>	11	<b>CAN I USE COOL CINEMATIC DATA?</b>	15
<b>WHAT ARE THE COMPONENTS USED IN A VISUAL SIMULATION?</b>	12	<b>GOOD PRACTICE</b>	16
The Realtime Application Program	12		
The Image Generator (IG)	12		
The Visual Database	12		
The Modeling Package	12		
Visual Realism	13		

## *How is Realtime Authoring Different?*

Surprisingly, authoring for dynamic visual simulation or gaming applications is not as much about graphics as it is the creation of efficient *data* that will be utilized to the greatest advantage in a realtime environment. A Visual Simulation Database refers to a file of data that describes a three-dimensional visual scene, as well as supporting data required for retrieving and displaying this data in a visual system.

Let's take a quick look at the goals of realtime applications and data authoring:

- **The emphasis is on immersive interaction between an active audience and responsive simulation.**
- **Real-world dimensions, rules, and constraints may be vitally important to the goals of the simulation.**
- **Frames must be fully rendered and displayed at 30 to 60 frames per second!**

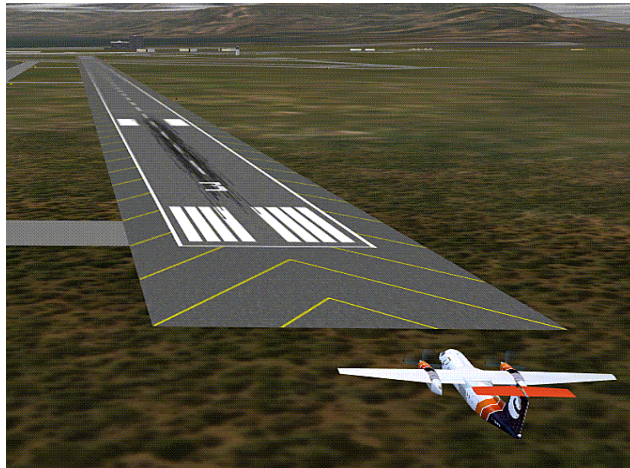

- **Efficient polygonal models contain only the necessary polygons to achieve the desired effect.**
- **Data structures are hierarchically optimized for program traversal and IG state control. Data also contains model controls, real-world constraints, and DIS optimizations.**

MultiGen Creator provides an integrated suite of tools designed specifically to aid in the creation and management of effective *realtime* databases.



## *Why is Visual Simulation so Interesting?*

In commercial and military worlds, immersive visual simulation is a remarkably inexpensive and safe alternative to physically testing new technology, tactics, or evaluating feasibility.

None of this has been lost on the gaming world, where even the most fanciful worlds benefit from realistic motion and model behavior.

And, of course, it is much more comforting to immersively watch an alter-ego get diced in realtime than oneself!

The primary benefits of visual simulation are found in many areas of today's world.



Some popular reasons to use realtime visual simulation are:

- **Walkthroughs and previews**
- **Intuitive immersive visualization of complex events**
- **Commercial and military event planning and rehearsal**
- **Training systems**
- **Accident visualization/reenactment**
- **Interactive/immersive gaming**

Visual simulation saves money, time, resources, and lives.

## What are the Components Used in a Visual Simulation?

### The Realtime Application Program

This program controls the graphical scene, how the user moves through the scene, as well as a wide variety of other dynamic events during the scene. Car driving and flight dynamic models, collision detection, and special effects such as explosions are included in the realtime application program.

### The Image Generator (IG)

The image generator, or IG, is the graphical hardware that draws the scene. It can vary depending on simulation requirements. Typical image generators are Indigo Impacts, Reality Engines or InfiniteRealities. Image generators can also be PCs and gaming consoles.

Image generator performance is measured in polygons-per-frame (*frame budget*) rather than in polygons-per-second. Performance can vary drastically depending on the graphical, CPU, and bandwidth horsepower within the image generator hardware platform. The term *Target IG* is used to reference the specific IG hardware platform that a simulation will run on.

### The Visual Database

The visual database is the data that describes what, when, and how to draw the scene. Creator uses the public domain OpenFlight format to store this information. Creator and OpenFlight are double precision, allowing as much accuracy as necessary when describing complex objects and very large area databases.

### The Modeling Package

Historically simple visual databases were created using text-based editors, Computer Aided Design (CAD) systems, or geometry that was hard-coded within the realtime application.



Today, MultiGen Creator can be used to build all of the individual elements of the visual database.

### Visual Realism

The strategy behind *visual realism* is an interesting and often overlooked element of visual simulation.

Effective models are designed based on what the audience expects to see or experience, not pictographic accuracy.

The perception of realism is gained by meeting the contextual expectation of the end product or simulation. If the user finds the expected visual cues for a given context and they make sense, all other details can be reduced or eliminated without compromising the simulation.

To explore this concept a little further, imagine a typical aircraft as viewed by three individuals. One is a new mechanic learning to perform a pre-flight examination of the aircraft. Another is a junior tower controller identifying and guiding the aircraft to a particular gate. The third is a police rookie learning traffic control around an airport and noticing the plane fly over.

Each has a completely different expectation for what the aircraft represents, how it must behave to be *realistic*, and what visual cues they need to do their job. Any simulation of their environments must take into account the special significance of the aircraft in that particular role.

- **If the focus of a driving simulator is the instrument panel, road, signs, as well as a few navigation points, put your efforts in these areas. Buildings and terrain can be added in incremental detail depending on platform performance, but are not necessary, and may interfere with the goals of the simulation.**
- **If the focus is an interactive dog-fight simulator, go for speed. The audience expectation is dynamic interactive performance and realistic aircraft response. Scenic accuracy is a secondary concern, and is only required for visual orientation or opponent identification. Everything else is easily satisfied by using low performance cost texturing and levels of detail.**
- **In your design, do not overlook the psychological aspects of perceptive reality: What happens when I run off the world? Shoot a target? Run into the bridge? Include these elements into the database.**

## *Can CAD Models be Used for Visual Simulation?*

Yes, with difficulty. Visual simulation modeling is very different than CAD data generation. As a result, even the best CAD models require significant amounts of cleanup work to prepare them for realtime.

CAD tools create accurate engineering data models which contain a great deal of useful information for engineering and drafting:

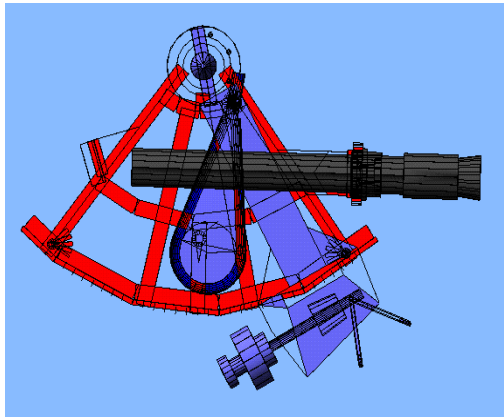

- **CAD goals: Model precision and mechanical integrity**
- **CAD data: Built-in engineering standards, accurate material specifications, and mass property data**
- **Graphic goals: Complex rules based data designed for engineering plots and static image generation**

Use CAD data only when necessary. Because the purpose of this data is not graphical in nature, virtually the entire CAD database offers little or no value for a visual simulation application. You can expect:

- **Significant hand reduction of excessive polygonal data to meet realtime modeling constraints.**
- **Nearly random polygonal data has to be hand organized and structured into useful polygonal groups.**
- **All visual simulation control elements must be added to the database.**
- **In many cases, it is easier to create a realtime model from scratch than to convert CAD data!**



## *Can I use Cool Cinematic Data?*

No doubt about it, cinematic modelers create wonderful *still* images. These images are generated using a variety of tools and processes, none of which are realtime. Some take hours or even days to generate!

For the most part, useful data generated by cinematic modelers includes polygons, color, material, and texture mapping data. Some include animation sequences. With cinematic data, you can expect:

- **Data Emphasis: Passive entertainment and artistic beauty.**
- **Finely detailed graphical models containing thousands of polygons in a flat data architecture (some tools offer structuring capability).**
- **Rendered images that incorporate ray traced spline surfaces with sophisticated material, surface, and lighting effects.**



Use cinematic data only when necessary, and only from sophisticated packages offering polygon reduction and data structuring. Because cinematic data is *too* graphical in nature, you can expect:

- **Significant hand reduction of excessive polygonal data to meet realtime modeling constraints.**
- **Flat polygonal data structures have to be hand organized and structured into useful polygonal groups.**
- **All visual simulation control elements must be added to the database.**
- **As with a CAD model, it is often easier to create a realtime model from scratch than to convert cinematic data!**

## *Good Practice*

The real secret behind a good visual database design is the liberal application of good rules of practices. As you move through the rest of this booklet, you will find a number of tips and tactics mentioned in their particular contexts.

By noting and applying each tip while you explore MultiGen Creator, you will find that your models will be easier to construct and manage.





## *Getting Started with MultiGen Creator*

### Introduction

The MultiGen Creator coordinate system, tools and controls let you build, move, and control your models to create a robust 3D world.

In this section, we explore the fundamentals of Creator space, preferences, and tools. This session also begins to explore the basic techniques of creating effective realtime models with MultiGen Creator.

### Contents

<b>THE BASICS</b>	19	<b>MOVING AROUND IN YOUR 3D WORLD</b>	23
		The Coordinate System	23
<b>STARTING CREATOR</b>	19	Zooming	24
<b>EXITING CREATOR</b>	19	<b>SELECTING GEOMETRY</b>	25
		Mouse Selection	26
<b>OPENING A FILE OR CREATING A NEW ONE</b>	20	<b>CREATE YOUR FIRST MODEL</b>	27
<b>SAVING YOUR WORK</b>	21	Clear the Workspace	28
Autosaving Files	21	Turn on the Grid	28
Other Files	21	Tips:	30
		Change the Grid Color	30
<b>WINDOW TOUR</b>	22	Set a Parent	31
		Use Mode to Control What is Created	31

Create a Face (Polygon)	33
Create a 3D Object	33
Raise a Peak	34
Raise a Wall	35
Create a Sphere	35
Move the Sphere	36
<b>WORKING WITH COLOR</b>	37
Opening the Color Palette	37
Applying Colors	37
Editing Colors	38
Restoring the Color Palette	38
Saving and Loading the Color Palette	38
Try This!	39
Admire Your Work!	39



## The Basics

### Starting Creator

This chapter assumes you have already installed MultiGen Creator, and have correctly set up the licensing. The **DesktopTutor** folder that is installed in the **MultiGen-Paradigm\resources\tutorials** directory contains source files necessary to do the exercises in this book. See the *MultiGen Creator Getting Started Guide* for information on installing and running Creator.

To start Creator in Windows, choose **Start>Programs>MultiGen-Paradigm>Creator 2.6** and choose **Creator** from the secondary menu.

**Tip:** You can also create a shortcut for Creator and keep it handy on your desktop. To do this, right click *mgfltx.exe* in the **\MultiGen-Paradigm\bin** directory. Select *Create Shortcut* from the pop-up menu to create the shortcut link, and then drag the shortcut to your desktop.

To start Creator in IRIX, open a shell window, change to the Creator directory (*/usr/local/MultiGen-Paradigm/creator*) and then type *creator*.

When Creator starts, a splash screen displays, and then the application window opens with a new, untitled database. You can stretch or expand the window to cover some or all of the screen using normal window controls.

### Exiting Creator

To exit Creator, choose **File/Exit** or type **Ctrl+Q**.

---

#### Note

Throughout this document, keyboard shortcuts are given when describing commands in Creator. The shortcuts given are Creator defaults, but they can be changed according to your preferences using **Info/Keyboard Shortcuts**.

---



## Opening a File or Creating a New One

Before you begin creating things, open an existing file and become familiar with navigation within the Creator 3D world.

Creator follows Windows platform conventions to open model files. To open existing files, choose **File/Open** (Ctrl+O). To create a new file, choose **File/New** (Ctrl+N). You can have as many model files open simultaneously within Creator as necessary!

To better explore the Creator environment, try opening one of the example model files provided with this tutorial. If you are using Windows, these files are found in the `\Program Files\Multigen-Paradigm\resources\tutorials\creator\DesktopTutor\Models` directory; if you are using IRIX, they are in `/usr/local/MultiGen-Paradigm/resources/tutorials/creator/DesktopTutor/Models`.

When you choose **File/Open**, the *Open Database File* dialog box displays. Note the file information and thumbnail image.

**File Information** Provides information for project tracking such as owner, revision date and number.

**Thumbnail Image** Thumbnail images (\*.icn) are images of the database file generated with the *View/Snapshot* tool. These are handy for cataloging your model files.

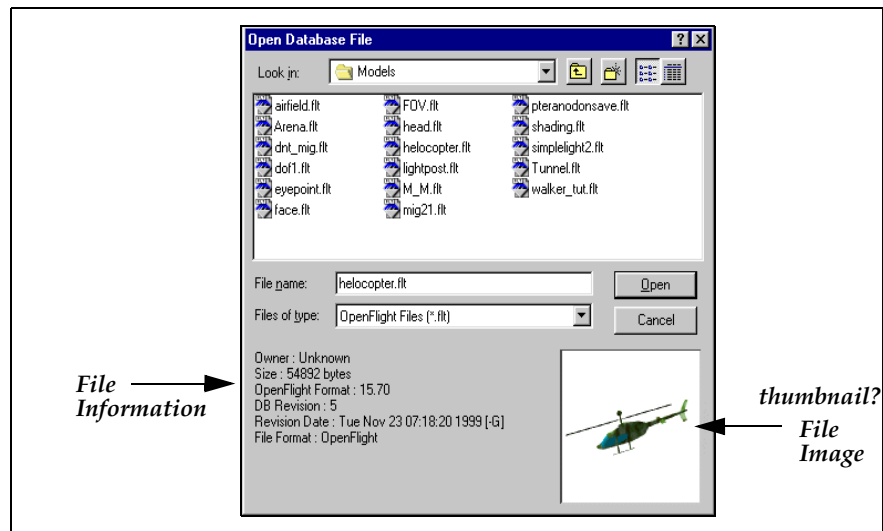

## Saving Your Work

You should develop the habit of saving your work frequently. This prevents your work from being lost in the event of a power loss or system malfunction. Creator provides all of the standard file tools in the **File** menu. You should already know how to use them!

<i>Save</i>	Saves the current file. Prompts before overwriting the original file with current information ( <b>Ctrl+S</b> ).
<i>Save As</i>	Saves the current file as <i>name</i> . Automatically appends the file name with a .flt suffix.
<i>Write Select</i>	Saves only the currently selected section of the model in its own file as <i>name</i> and automatically appends a .flt suffix.
<i>Close</i>	Closes the current file. If the file has not been saved, a dialog box appears asking whether you want to save the file first ( <b>Ctrl+W</b> ).

In addition to saving your model geometry, OpenFlight files also saves related color, material, texture, and other attribute information.

You can save OpenFlight files wherever you want to place them. Most users create project-specific directories containing all the models and textures related to particular projects.

If you are saving the file to a new directory, it is a good idea to directly save your working file once into the project directory using *File/Save As*. You can then use Autosave to automatically update your files.

### Autosaving Files

You can set the *Autosave* features as Preferences by choosing *Info/Preferences* (**Ctrl+Shift+P**) and then clicking the *Flight* tab:

If *Keep Backup Files* is set, Creator makes a backup file for each OpenFlight file opened.

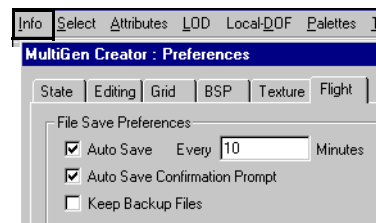

### Other Files

In addition to the OpenFlight file, Creator also creates the file *creator1.prefs*, which saves user-defined preference settings. *creator1.prefs* is read each time Creator is launched. If Creator cannot find this file when it starts up, settings revert to default source definitions.

## Window Tour

Creator windows contain all of the tools, views, and capabilities you need to create your worlds. The *Application* window has a menu bar and toolbar along the top, and a toolbox caddy on the left side of the window. Each *Database* window has its own control bar that controls the eyepoint position. The illustration below points out the important general controls. Open the file `\Program Files\MultiGen-Paradigm\resources\tutorials\creator\DesktopTutor\Models\helicopter.flt` (for IRIX open `/usr/local/MultiGen-Paradigm/resources/tutorials/creator/DesktopTutor/Models/helicopter.flt`) and take a few minutes to explore the interface for a bit. When you are done, leave one Graphics view and one Hierarchy view open.

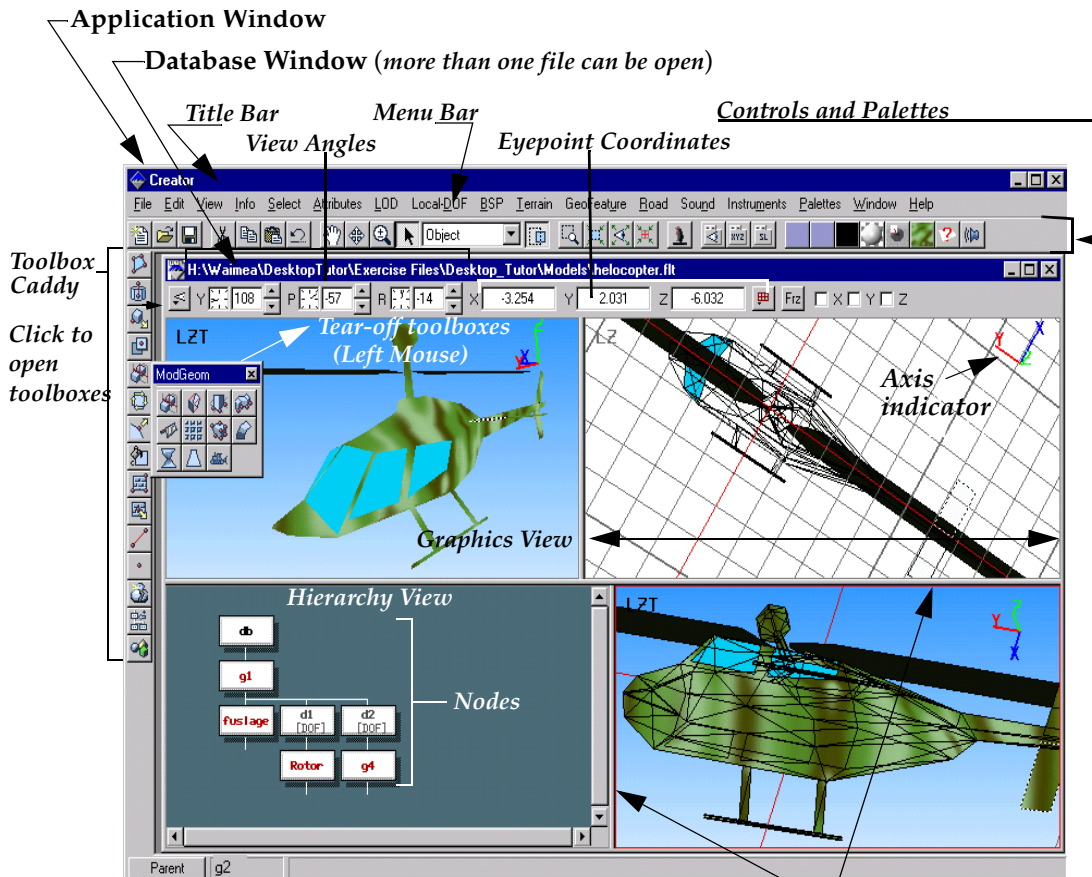

Parent Button: Assigns which node receives new geometry

Up to four viewing panes can be opened by dragging their sashes from the bottom or right edge of the window



## Moving Around in Your 3D World

### The Coordinate System

Creator uses a Cartesian coordinate system: X, Y, and Z.

When a graphics file is first opened, the default eyepoint is positioned at the center of the universe  $(0, 0, 0)$ , and then moved to a point looking in the Y direction and down toward  $(0, 0, 0)$ .

You can set the default eyepoint in the *Info/Preferences/State/Graphic Viewing Defaults* preferences and *View/Viewing Volume* parameters. These settings can be changed to suit particular needs. For example, you could set your view looking off into empty space!

After initialization, you can easily change your view and orientation using the controls shown below. Try each one!

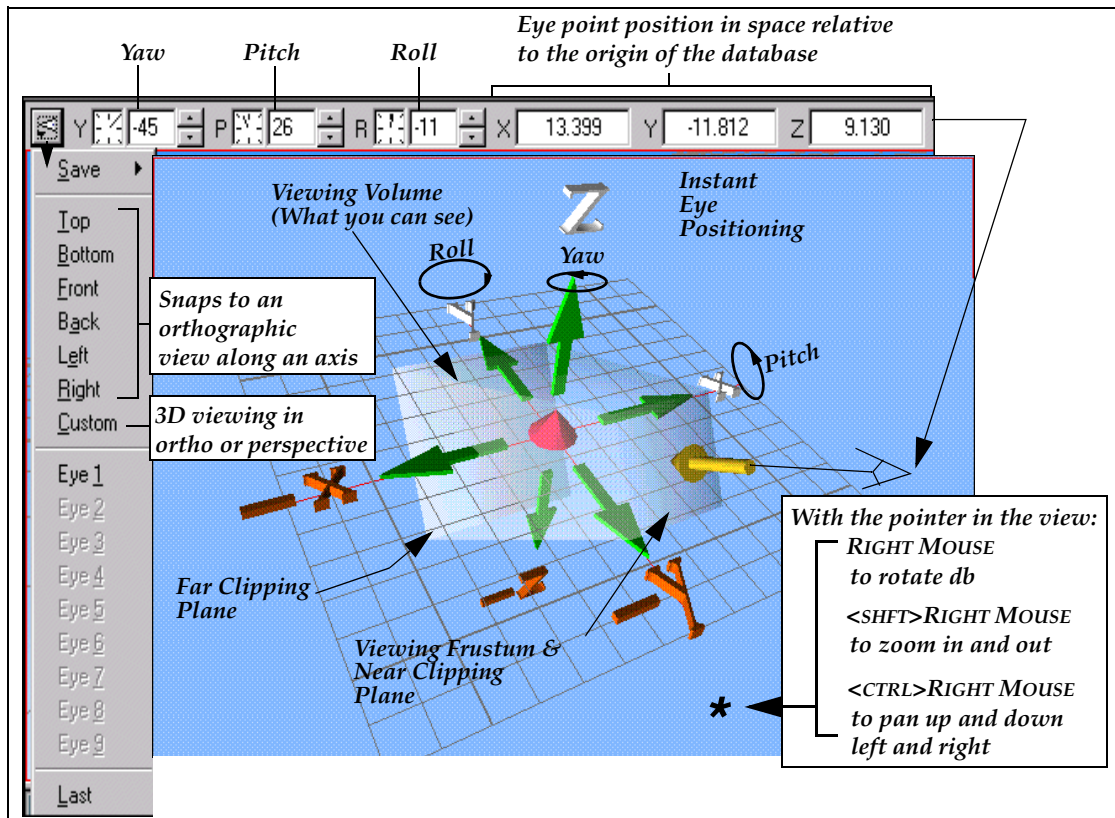

You can use the four view controls near the center of the toolbar to reset your view to defaults or to focus on a particular section of the model.

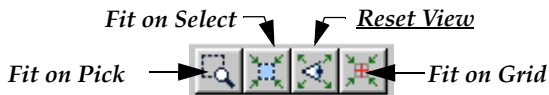

**Fit on Pick**

When this control is selected, the pointer changes to a crosshair. Fence-select an area of the model. This area will be centered in your view (Graphics view only). Shortcut: **Ctrl+F**.

**Fit on Select**

Selecting a portion of the model, or a node in the Hierarchy view and then clicking **Fit on Select** will center the selected item in the view. Shortcut: **v**.

**Reset View**

Resets the view to the default yaw, pitch, and roll specified in the Flight preferences. Shortcut: **u**

**Fit on Grid**

The grid is a graphic display of the coordinate system that can be arbitrarily sized. Fit on Grid centers the entire displayed grid in the view. Shortcut: **Ctrl+Shift+V**.

## Zooming

Pressing the *v* key (Fit on Select) centers your view on any selected item and makes that item the center of rotation for the right mouse Yaw, Pitch, and Roll operation. Centering rotation on the focus of your attention is a uniquely valuable feature for editing.

- Step 1** Select Reset View to center your model in the Graphics view.
- Step 2** Select the right wing by clicking the mouse on it. The entire half of the aircraft will be selected.
- Step 3** Enter *v* on the keyboard, or click Fit on Select.
- Step 4** With the pointer in the Graphics view and holding the right mouse button, drag the cursor around. Note the view rotates around the center of the right wing.
- Step 5** Enter *u* to reset the view, then repeat the process using the left wing. Note how the center of rotation is at the left wing.



## Selecting Geometry

Something must be selected in order to perform any editing activity. But when you click on something, just what is selected? The *scope* or area selected is determined by the current mode. Modes constrain selection to a single vertex or to larger areas of the model (see table below). They can also constrain selection to light sources, sound nodes, or any other specialized node within the database.

Setting a mode identifies the kind or level of database component you want to select for editing.

**Mode button**

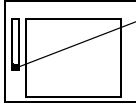







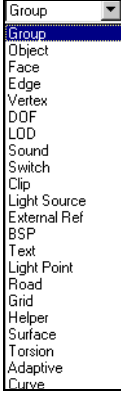



**Graphic Modes**



**Mode Select Menu**



Modes	Selected	Db Nodes
		db (Black)
 <i>Group</i>		g1 (Red)
 <i>Object</i>		o1 (Green)
 <i>Face (polygon)</i>		p1 <div style="display: flex; justify-content: center; align-items: center;"> <div style="border: 1px solid black; padding: 2px; margin-right: 5px;">Sub-face</div>  <div style="border: 1px solid black; padding: 2px; margin-left: 5px;">p1 (Color)</div> </div> <div style="display: flex; justify-content: center; align-items: center;"> <div style="border: 1px solid black; padding: 2px; margin-right: 5px;">Super-face</div> </div>
 <i>Edge</i>		
 <i>Vertex</i>		V1 (face attribute)

Give it a try! As you select each mode, left click the body of the helicopter.

## Mouse Selection

Screen selection is done by clicking or dragging a fence around the item or items to be selected with the left mouse button.

### *To select a single item*

Click once on the item to be selected.

If the item is an edge or a vertex, drag a selection fence across it.

### *To select two or more contiguous items*

Drag the mouse over the items to be selected. Anything that is touched by the fence will be included (if Fence Touching is on).

### *To select two or more separate items*

Click the first item, then Shift-click to select each additional item.

### *To deselect an item*

If you inadvertently include an unwanted item in a selection group, Shift-click to deselect it. The other items will remain selected.

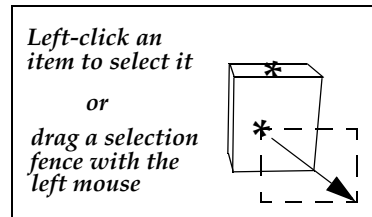

## *Create Your First Model*

You can navigate, select, and use modes! Now you are ready to begin creating something!

Creator is a structured modeler. At first, creating something might appear to be complex because it takes much more space to explain something than time to actually do it, and at all times, you are creating both geometry and an ordered database simultaneously.

But all this really amounts to is selecting a node as a place to put whatever you are creating next (“setting the parent”) and using a tool or two to create the new geometry.

Take the time to understand this section. In actual practice, the activities you see in this section become so automatic, you hardly give them a conscious thought.

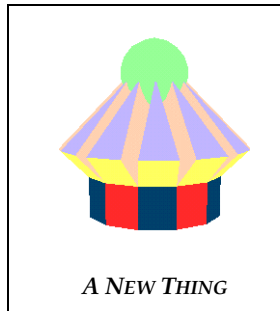

## 2 Getting Started with MultiGen Creator *Create Your First Model*

### Clear the Workspace

- Step 1** If you still have `helicopter.flt` open, close it by selecting *File/Close*, or type **(Ctrl+W)**.
- Step 2** Create a new file by selecting *File/New* or by typing the shortcut: **Ctrl+N**.
- Step 3** Choose *File/Save*, and name the file `thing.flt`
- Step 4** Use the mouse to grab the bottom of the database window and pull the window sash about half way up, displaying the Hierarchy view.

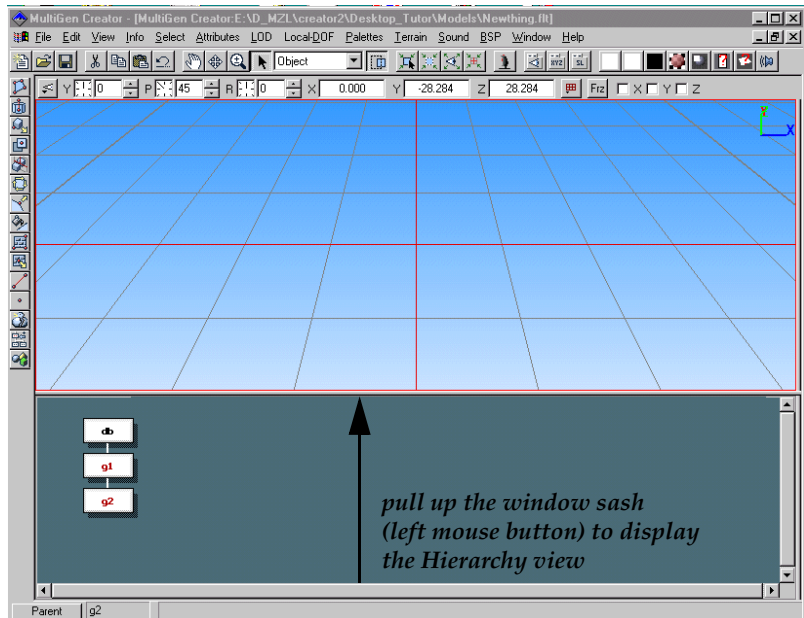

### Turn on the Grid

When creating models, it is useful to have a scale or grid indicating coordinate locations.



**Step 1** Open the View panel and click the Grid On/Off button (see illustration) to turn on the grid.

*The tracking plane and its related grid serve as a surface on which you construct and place graphic objects. The tracking plane can be placed in any location or orientation in space*

The screenshot shows the 'View' panel of MultiGen Creator. The panel includes a toolbar with various icons, a 'Texture' dropdown set to 'Layer 0', 'Draw Mode' set to 'Wire/Solid', and 'Draw Order' set to 'Z Buffer'. The 'Grid' section is highlighted with several annotations:

- Grid On/Off:** Points to the grid icon in the toolbar.
- Grid Snap on/off:** Points to the 'Snap' icon.
- Reset plane to XY:** Points to the 'XY' button.
- Grid Type: Cartesian/Radial:** Points to the 'Grid Type' dropdown menu.
- Grid projected over, under, or Z buffered with objects:** Points to the 'Draw Grid' dropdown menu.
- Grid Larger:** Points to the 'Larger' button.
- Grid Smaller:** Points to the 'Smaller' button.
- Rotate Grid (Use XY to reset):** Points to the 'Rotate' button.
- Tracking plane placement and orientation controls:** Points to the 'WTR', 'FRP', and 'VIEW' buttons.
- Dimension: distance represented by each grid point:** Points to the 'Dimension' input field.
- Turn on/off grid quadrants:** Points to the quadrant control buttons.

To the right of the panel, a diagram shows a 3D coordinate system with a grid on the XY plane. The grid is labeled 'Grid' and the plane is labeled 'Tracking Plane'.

*The grid is for your visual convenience. Visible or not, the tracking plane and grid always exist and extend to "infinity" for coordinate placement.*

**Step 2** Take a moment to try some of the other controls. When you are done exploring, reset the tracking plane to the correct position by clicking the XY button.

**Tips:**

- Slide the View panel to the side of your screen and leave it open. You will find it very useful when constructing geometry
- XY resets the tracking plane to the center of the world and in the correct orientation
- Display the smallest sized grid you find useful, and in the most practical units for the scale of your work

**Change the Grid Color**

If you don't like the default color of the grid and axis lines, you can change them in the *Info/Preferences* menu.

**Step 1** Choose Info/Preferences and click the Color tab.

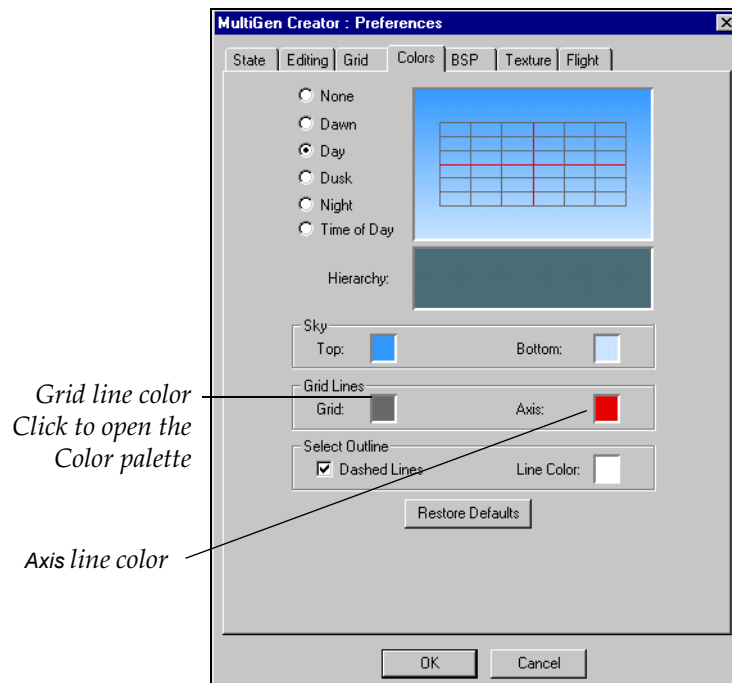

**Step 2** Click the Grid color sample to open the Color palette. Choose a new color, and click OK. The grid in the Graphics view will update with the new color.

**Step 3** Repeat Step 2 to change the color of the axis lines.



## Set a Parent

**Step 1** In the Hierarchy view, click the red Group node *g2*, and then click the Parent button in the lower left corner of the application window. The Set Parent shortcut is Alt-left click the node you want as the parent.

By setting a parent, you are instructing Creator to place the new geometry at a certain point in the data hierarchy. The node we are attaching new geometry to is a *parent*. Nodes attached to a parent are *children* or *child* nodes.

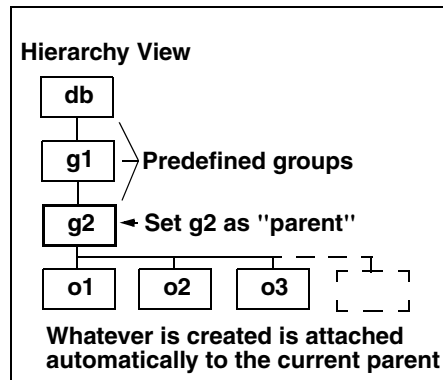

**Tip:** Nodes do not have to be meaningless letter or number codes; you can give them meaningful names for readability. To rename a node's name:

- Select the *g2* node.
- Select *Attributes/Rename* (or enter Ctrl+J).
- Enter a new name for the node in the popup panel. Only the first 7 characters will show on the node itself.

**Tip:** Name only the larger groups of your model. Group nodes named car, sunroof, left door, hood, and wheel are easy to read and understand. It is less important to name objects and polygons underneath the groups unless they have specific significance.

Data structuring dramatically improves the readability of your model organization and structure, particularly when identifying specific model components for special effects. Structuring also significantly improves the quality of life for your programmers.

## Use Mode to Control What is Created

Since you will want each created item to have its own identity in the database, you can use an *Object* mode to instruct Creator to automatically gather future polygons under hierarchical Object nodes.

**Step 2** Select *Object* as your modeling mode. When you create any new geometry, an Object node will be created for you containing the new polygons.

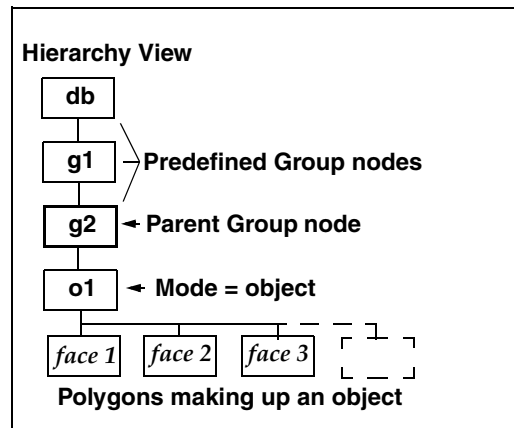
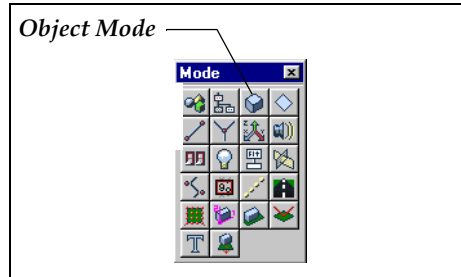

Something to remember about creating with modes:

- If Face mode is selected, polygons (faces) will be created directly under the assigned parent.
- If Object mode is selected, an Object node will be created under the group parent and the polygons will be collected under the Object node. Note: Object nodes are not required and can only contain faces. For this reasons, Many users use Group nodes only.
- To create another object, reselect g1 (or any group) as the current parent and begin generating new geometry.



## Create a Face (Polygon)

Face Creation tools create rectangular faces, n-sided circles, and irregular n-sided polygons. We are going to make a circle, so the *Face Creation/Circle* tool will be the first tool to use. A Circle tool pop-up panel (shown below) will guide your steps.

- Step 1** In Face mode, choose the circle tool from the Face Tools toolbox.
- Step 2** With the left mouse, click the first of two points on the tracking plane. The dialog box prompts you for the second point. By holding and dragging the point with the left mouse, you can move it exactly where you want it.

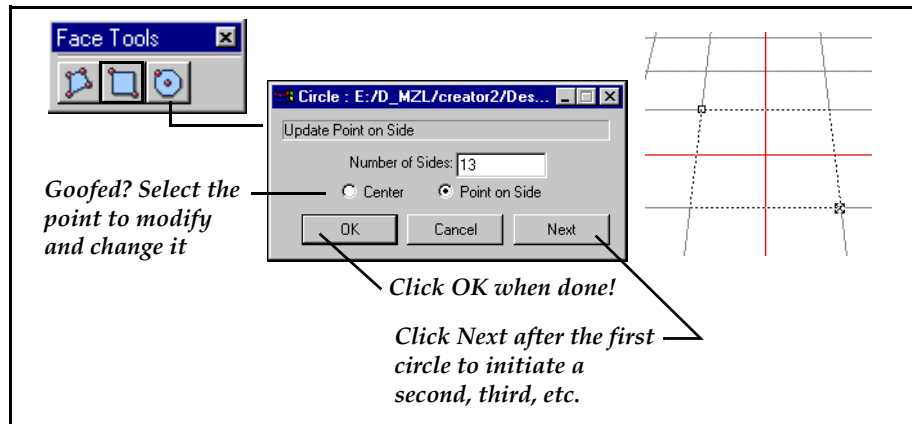

---

### Note

All construction tools permit you to individually select and move control points before clicking OK. To select the errant point, click its option button or hold down Ctrl while clicking the point.

---

## Create a 3D Object

Geometry tools are used to construct more complex objects. The Geometry tools *Wall* and *Peak* are handy in giving dimension to flat polygons.

## Raise a Peak

A peak adds the faces and common center for a peaked roof or pointed end. As with a wall, one or more faces can be peaked simultaneously.

- Step 1** Select Geometry Tools/Peak to start the Peak tool.
- Step 2** Drag the height indicator up to about 4 units, and click OK.

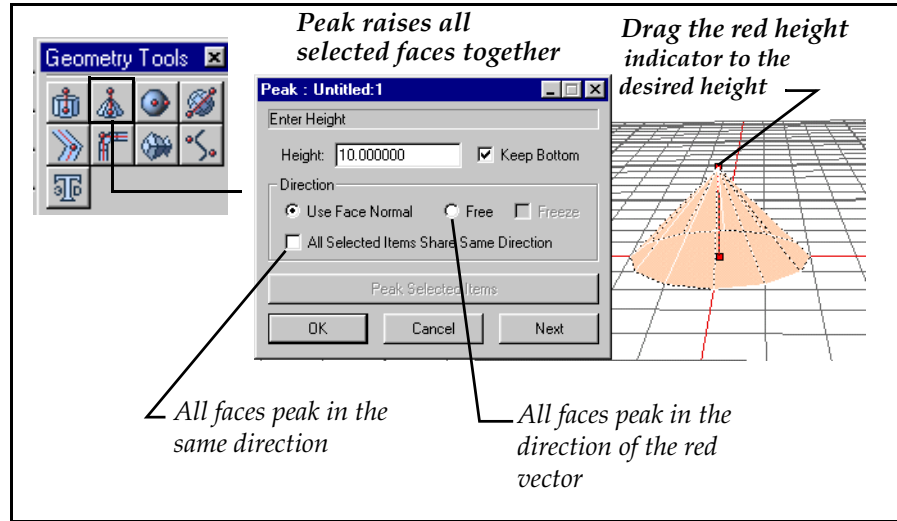

**Tip!** It is important to eliminate unused or non-visible faces in any model you create. Had this object been a “ground object”, you would ordinarily deselect the **Keep Wall Bottom** flag, eliminating an otherwise invisible and unused bottom polygon. In this case, you want to keep the bottom face.



## Raise a Wall

- Step 1** Select the Wall tool.
- Step 2** Use the mouse to raise the walls by dragging the red vector up and down, or enter a specific height in the Height field, such as 6 or 7. Click OK and leave the cylinder selected.

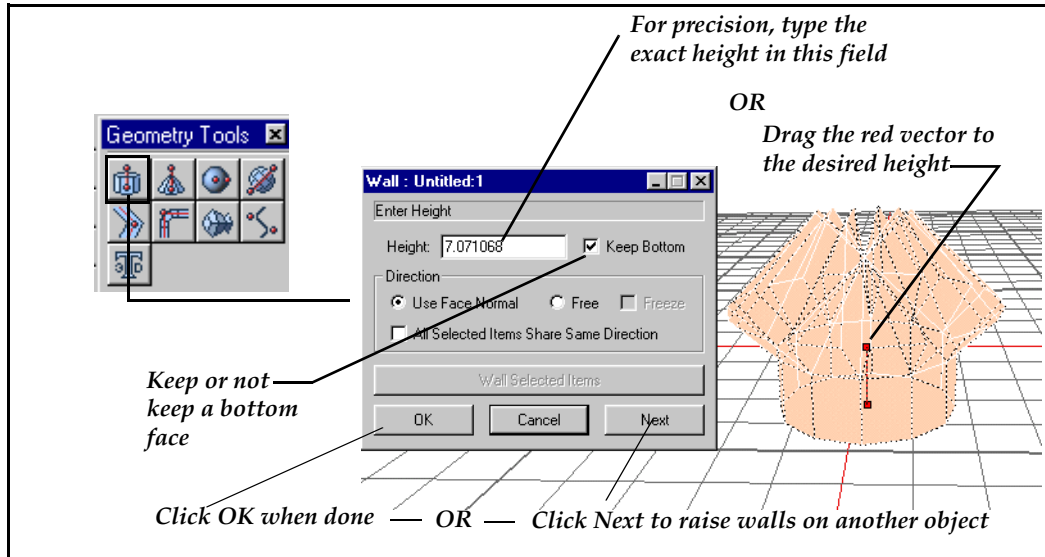

## Create a Sphere

The Sphere tool creates a sphere of sub-divided triangles. You will find the Sphere tool in the Geometry Tools toolbox. This tool must be used carefully because it can generate a very large number of faces.

- Step 1** Select the Sphere tool and enter a Number of Subdivisions such as 3, which should be the default.
- Step 2** Click a point on the grid. Select the point on the side one unit away, and then click OK. Leave the sphere selected.

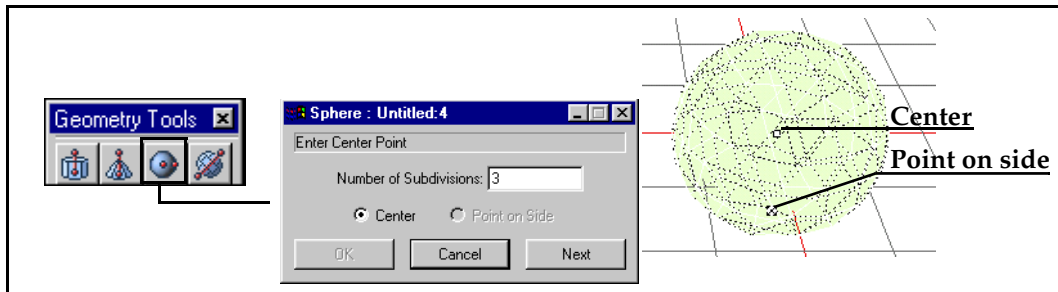

## Move the Sphere

The Translate tool is used to move geometry from one place to another. For this exercise, you will move the sphere from its present location to the top of the peaked 3D object.

- Step 3** In Object mode, select the sphere.
- Step 4** Choose Maneuver Tools/Translate. A From Point will display on the bottom of the sphere. Leave it where it is, and click To Point.
- Step 5** Middle click the point in the center of your 3D object (you may have to rotate your object by dragging with the right mouse to view the top), and click OK. The sphere will be moved to the new location.

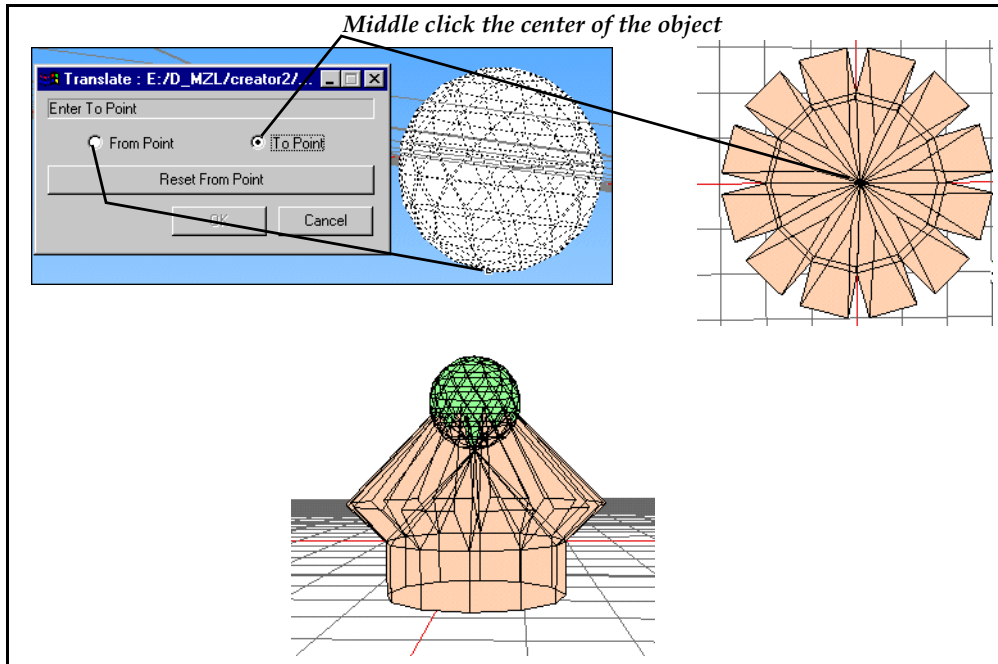

## Working with Color

In MultiGen Creator, you select a primary or “current” color from the Color palette and apply it to one or more selected groups, objects, faces, or vertices. The current color is automatically assigned to all new geometry until a new current color is selected.

### Opening the Color Palette

To open the Color palette, select *Color* from the *Palettes* menu to display the color palette, click the *Current Primary* color icon on the control bar, or use the shortcut, **Ctrl+P**:

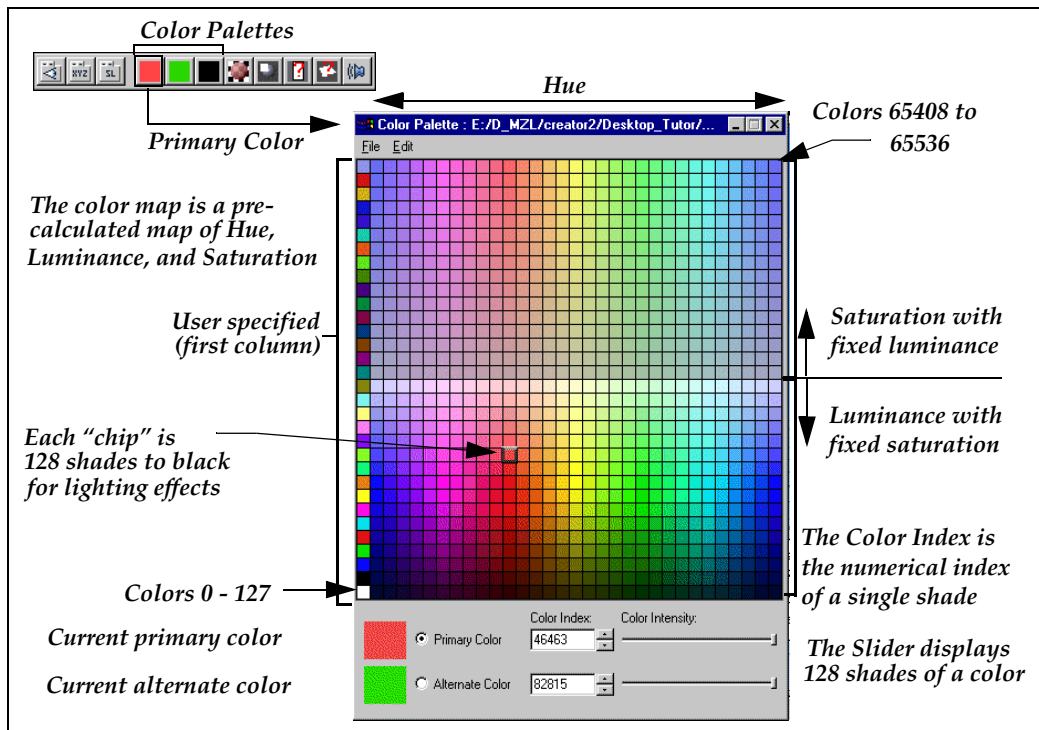

### Applying Colors

The *Current Primary* color is the color applied to geometry. The *Current Alternate* color is used for light points and texture effects.

To apply the *Current Primary* color, select the object to be colored and enter **Ctrl+R**, or choose *Insert Color* in the *Edit* menu.

**Note:** Each OpenFlight file is saved with its own Color palette. You can create custom Color palettes and save them separately to use as a shared Color palette for all common project models.

## Editing Colors

You can edit any color chip in the Color Editor. Double-click a chip in the Color palette to open the Color Editor, or select a chip and choose *Edit/Edit* in the Color palette menu.

Each Color palette entry represents 128 shades of a color (from white to black). The color you create or select in the Color Editor replaces the “top” color. The remaining 127 shades to black are automatically calculated for you.

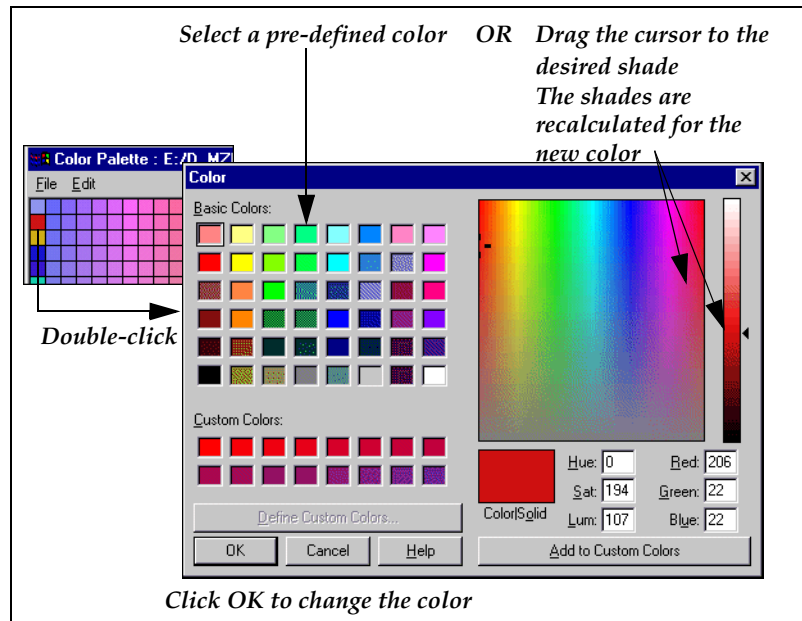

## Restoring the Color Palette

To restore your Color palette to the default color set, choose *Edit/Make HLS Map* in the Color palette menu.

## Saving and Loading the Color Palette

An edited Color palette can be saved as a unique file for sharing between models or in a common project archive.



Save the palette by opening the Color palette, and then selecting *File/Save Palette*. The file name is appended with an extension of .color to keep it self-identifying.

You can load a saved Color palette at any time by opening the current Color palette and selecting *File/Load Palette*.

### **Try This!**

If you haven't already selected and applied colors to your model, go ahead and select various faces and color them!

- Step 1** Set the modeling mode to Face (Shift+F).
- Step 2** Select one face or select several faces in your model. You can select multiple faces by dragging a fence along adjacent faces or by holding down Shift while selecting the faces you want.
- Step 3** Open the Color palette (Ctrl+P), and choose any color as a Primary color. Leave the Color palette open, but slide it off the Graphics view.
- Step 4** Type Ctrl+R to insert the new Current color into your selected object.
- Step 5** Continue selecting and inserting colors into parts of your model until it is all colored. Rotate the model around with the right mouse button to get to all sides.
- Step 6** Close the Color palette and save your file.

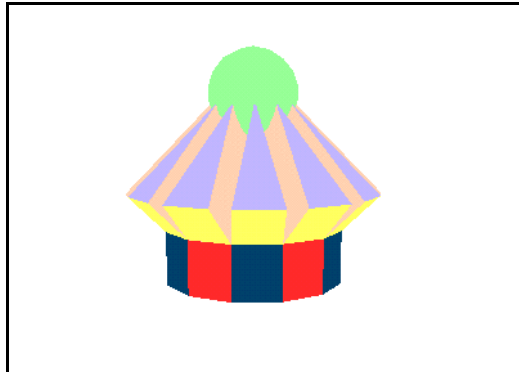

### **Admire Your Work!**

Use the right mouse button to rotate your model and admire your work. You can also make your model fly by itself. Press and hold both the middle and right mouse buttons and drag the mouse a short distance in any direction. Your model will spin until you release the buttons.

## 2 Getting Started with MultiGen Creator

### *Working with Color*

You can also fly your model by pressing Ctrl and clicking one of the eyepoint clocks. Click **OK** in the *Spin View* dialog box to stop the spin.

*To automatically spin your model, press Ctrl and click one of the eyepoint clocks*

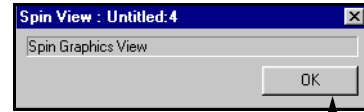
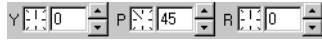

*Click OK to stop the spin*





## *Construct Your First Realtime Model*

### Introduction

Beginning with this chapter, you will construct your first realtime model using MultiGen Creator. During the course of the next few chapters, you will also structure the database, add lighting and texturing. The end result will be a good example of a realtime model.

Throughout this chapter, always remember that you can use the various tools in any meaningful order or combination. As you create each model component, the approach exemplified here is only one of many possible solutions.

### Contents

<b>THE GENESIS OF A REALTIME MODEL</b>	43	Make the Other End	53
A Policy of Good Practice	43	Fix the Wrong Sided Polygon!	53
<b>A CLASSIC FARMHOUSE</b>	44	Create the Front Gable	53
Modeling Goal	44	Raise Gables for Height	54
Modeling Objectives	44	Delete a Hidden Face	55
Define Your Database Parameters	45	Make the Long Roofline	55
Set up Your Viewing Environment	46	Make the Roof Cross-Section	56
From the Ground Up	47	Extend the Roofline	56
Check Your Hierarchy	48	Create the Overhang	57
Preparing for the Walls	48	Create the Front Roof Cross-Section	58
Lay the Floorplan Down	50	Extend the Peak	59
Raise the Walls!	50	Slice to Fit	59
Creating a Gable	51	Cleanup	60

Remove Construction Points	60
Doing Windows	61
How to Select the Correct Face in the Hierarchy View	61
Making Subfaces	62
Cut the Window in!	63
Your Challenge!	63
Preparing for the Front Porch	64
Make the Posts	65
Create the Porch Roof	66
The Chimney	67
Prepare the Hierarchy	67
Position the Tracking Plane	67
Make the Chimney	68
Cleanup	69
Rotate the Chimney	69
Plant the Chimney	70



## *The Genesis of a Realtime Model*

As you construct your first model, you will be introduced to many Creator functionalities. Equally important, you will learn useful tips and techniques that will serve you well in any modeling environment. After this introduction, you will find yourself becoming quicker and more proficient with the various tools and functions as you proceed through the rest of this book.

### **A Policy of Good Practice**

The key to successful realtime model making is to consistently apply a few short rules to every model you make. These rules make up what could be called the *Rules of Good Practice*.

For now, simply skim the rules listed here. Don't be concerned if this is unfamiliar territory. Each rule will be repeated, explained, and demonstrated throughout the examples in this book.

- **Everything in realtime is driven by your polygon budget; the number of polygons your realtime system can process and draw in 1/60th or 1/30th of a second.**
- **Put detail only where needed. Use Levels of Detail to build detail into areas of focus and generalize the rest.**
- **Carefully plan the database structure. A well designed database significantly improves realtime performance.**
- **Be aware of the strengths and limits of your target realtime system. For example, grouping same color polygons can reduce time lost to mode changes on some systems.**
- **Eliminate tiny features that are two pixels or less at scale.**
- **Build the database ground up and inside to out to reduce culling and polygon sorting.**
- **Eliminate T vertices, where a polygon vertex falls along the edge of another coplanar polygon without a matching vertex.**
- **Reduce pixel depth (the number of times pixels are re-drawn) by combining closely overlapped models.**
- **Limit the use of subfaces, particularly for z-buffered systems.**
- **Substitute textures for detail where reasonably possible.**

## *A Classic Farmhouse*

### **Modeling Goal**

This tutorial leads you through the construction of a farmhouse.



The farmhouse was chosen because it poses a number of challenges to the novice and provides many opportunities to make important modeling decisions. The farmhouse also presents the opportunity to explore and try out many of the more interesting features and capabilities of MultiGen Creator.

### **Modeling Objectives**

The objective of this session is for you to become comfortably familiar with the general tools of model construction in MultiGen Creator and the basic strategy of model construction. That you will probably get a little “creative” along the way is, well, simply fun.

The skills you will learn include:

- Fully utilizing mouse and viewing features
- Advanced tracking plane positioning and use
- Fully utilizing Face, Geometry, and Maneuver tools
- Modifying and selecting colors from the Color palette

*Remember:* UNDO is 32 levels deep! Mistakes are OK!



**Define Your Database Parameters**

For a completely new project, a few basic parameters must be defined to determine the scope and measure of your database. As you set each parameter, be sure to note where each parameter is located and what else might be around it.

- Step 1** Create a new file (*File/New*) called *farm.flt*.
- Step 2** Pull up the window sash to split the window into Graphics and Hierarchy views.
- Step 3** Open the Info/Preferences panel and click the Flight tab.
- Step 4** Set Default Database Units to *feet*, and then click OK to close the panel. All units are now regarded as *feet*.

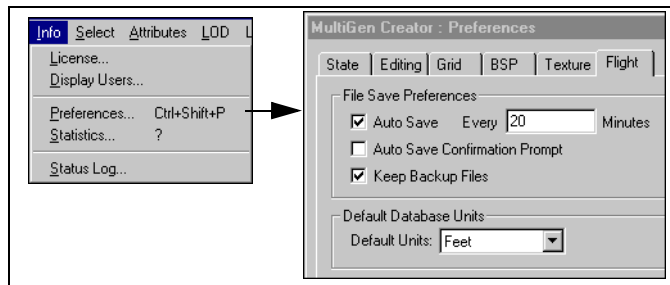

- Step 5** Open the View panel and set up the grid to suit your purpose:

*Setting up Your Display Controls*

*Turn on the grid*

*Turn on Grid Snap*

*Use a rectangular grid type for most modeling*

*Display the grid over the model to begin with*

*View tools control what is displayed*

*Activates various display features. Leave only lighting on for now*

*Set Draw Mode to Wire-Solid for editing*

*Make sure Offset = 0.0*

*A dimension of 1 indicates 1 foot per gridline; 2 indicates 2 feet per gridline, etc.*

## Construct Your First Realtime Model

### A Classic Farmhouse

**Hint!** If the View panel is grayed out, your input focus is not in the *Graphics* window. Click within the Graphics view to make sure the input focus is in that window.

**Step 6** Make sure the Dimension field is set to **1.0**. If this is not the value, change the value to **1.0**.

## Set up Your Viewing Environment

**Step 7** Your screen should look like the screen shown below. Leave the View panel open and drag it to the side for later use:

*Slide the view panel to the side and leave it open for convenience*

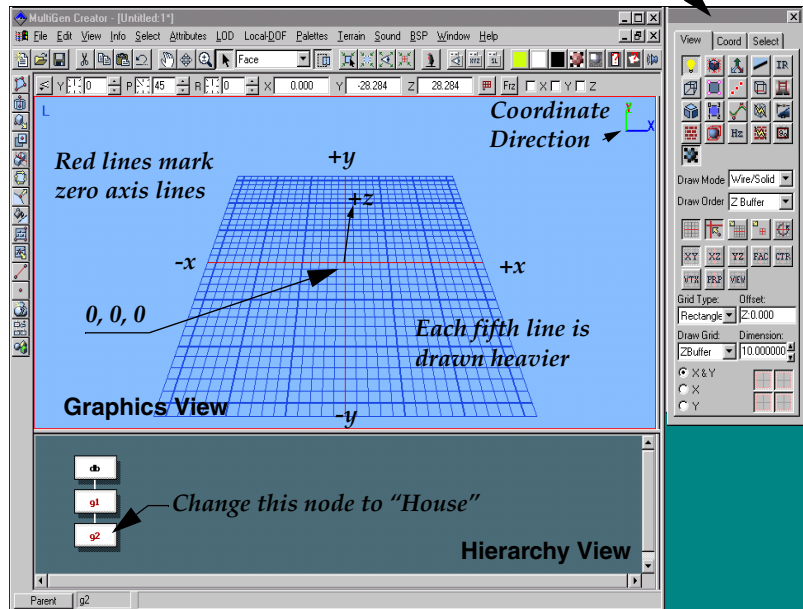

**Step 8** In the Hierarchy view, Alt+click the g2 node to set it as the current parent.

**Step 9** Select the g2 node and change its name to *House* (Ctrl+J). Enter the name into the dialog box and click OK. All of the components making up the house will be hierarchically attached to this node or its children.



## From the Ground Up

Constructing the house from the bottom up ensures a logical structure to the data and reduces polygon sort and handling time for the realtime system. Following this rule, start with the 31' x 23' foundation of the house.

### Building the Foundation

Constructing the foundation includes drawing a single rectangular face and using the Wall tool to raise its sides.

**Important:** Coordinates are given as (x,y) values. The coordinate (+16, +10) means 16 units in the X direction and 10 units in the Y.

**Step 1** Select Object mode.

**Step 2** Select the Face Tools/Rectangle tool.

**Step 3** In the Graphics view, click on the grid coordinates (-15, -13) for the first point and (+16, +10) for the second point (remember the heavy blue lines are five units), and then click OK.

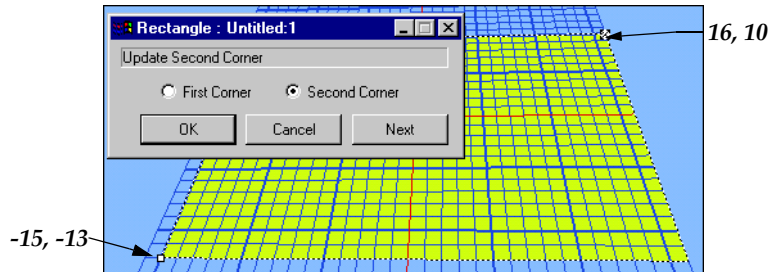
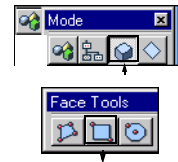

**Step 4** Raise the walls 1.3 feet to complete the foundation. Clear the Keep Bottom checkbox (the bottom is on the ground), and then click OK.

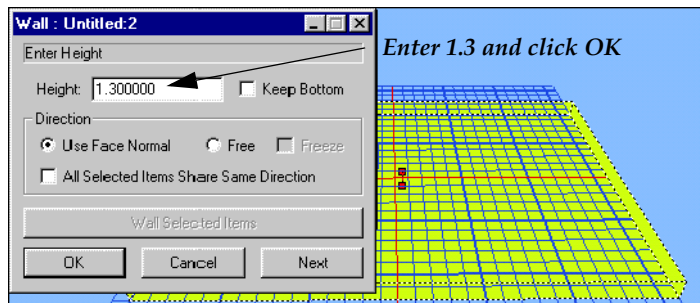

## Construct Your First Realtime Model

### A Classic Farmhouse

#### Check Your Hierarchy

- Step 1** In the Hierarchy view, you should now have an Object node under *House*. Select the Object node, and enter Ctrl+J to change the name to *Foundation*.
- Step 2** Alt-click the House node to reset it as the current parent.
- Step 3** Create a new group under the House node with the Create Group tool, and rename it *Walls*:

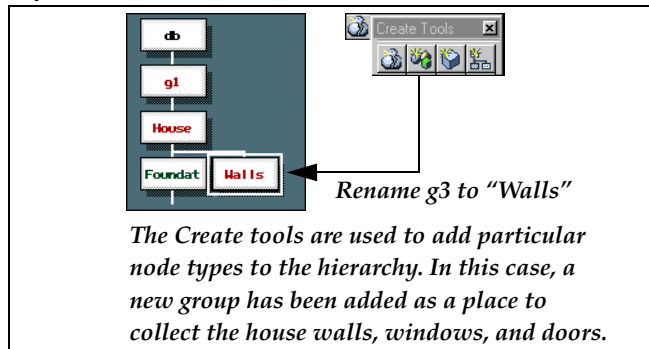

#### Preparing for the Walls

- Step 1** Alt-click the Walls node to make it the current parent. All new objects will be created under the Wall node.
- Step 2** To build the walls on the surface of the foundation, use the View controls panel FAC tool to snap the tracking plane to the top surface of the foundation. Look carefully at this illustration:

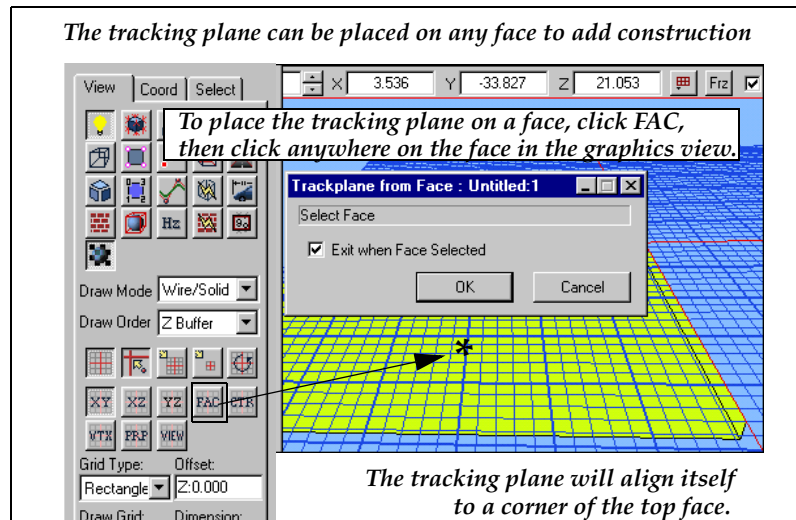

## Construct Your First Realtime Model

### *A Classic Farmhouse*

- Step 3** Align the tracking plane origin to a more convenient corner using VTX. If you place the center of the tracking plane at the lower left front vertex of the foundation, you can enter positive coordinates for the floorplan.

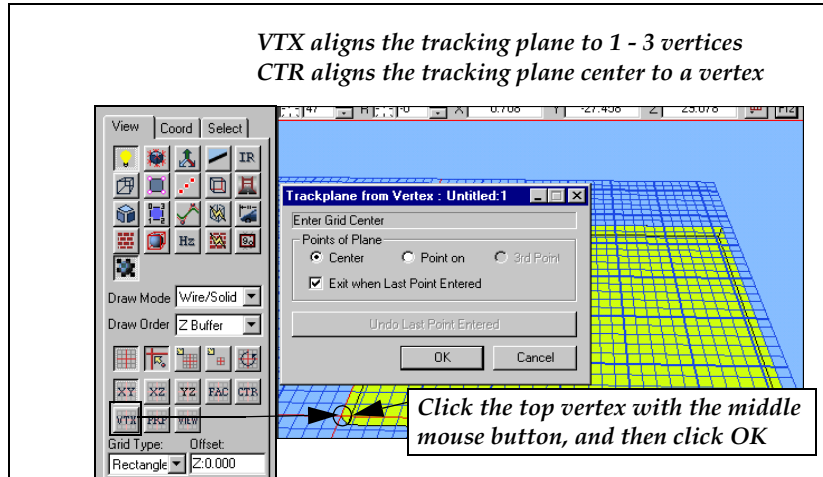

- Step 4** Change the current color (Ctrl+P) to a contrasting color to distinguish the walls as you create and raise them. The color is automatically applied to the new faces.

# Construct Your First Realtime Model

## A Classic Farmhouse

### Lay the Floorplan Down

**Step 1** Use the Polygon tool to create the floorplan.

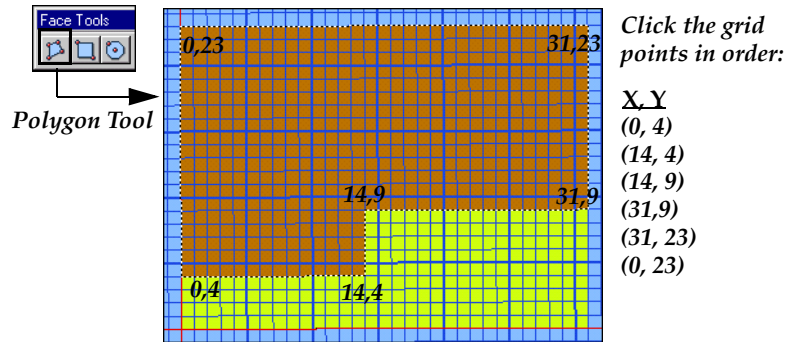

As an aid, set your yaw, pitch, and roll to 0, 90, 0 for a top-down view.



You might notice that the floor plan is a concave polygon (point 14,9). This is not a good practice. Concave faces cause serious performance drags when rasterized, and many realtime systems do not allow them at all.

In this exercise we will use concave faces during some construction steps, then we will delete them.

### Raise the Walls!

**Step 1** With the floorplan still selected, raise the walls to 12 feet using the Wall (Shift+W) tool. Try lowering your pitch 45 degrees to get a better view, and then click OK:

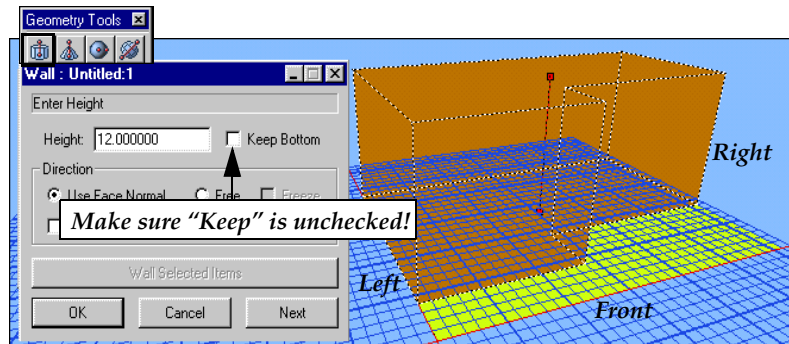

## Creating a Gable

The roofline involves three gables that must be exactly the same height, and the peaks must be precisely located above the wall.



Gables

Use a construction point, a grid offset, and the Project tool to gain precise control. Let's begin!

**Step 1** With the right mouse, rotate the house so you are facing the narrower (right) end, or set the eyepoint controls to (-90, 35, 0). Make sure you can easily see the length of the back wall.

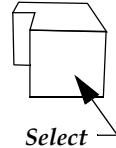

**Step 2** In Face mode (Shift+F), select the end face.

**Step 3** You will need to know where the center of the end face is located to center the gable peak above the face. Choose *Average Vertex* in the Vertex Tools toolbox to mark the center with a construction vertex.

### *Vertex Construction Tools*

*Vertex tools create precisely located temporary anchor points for the placement of the tracking plane or geometry.*

*Select a face  
or a volume*

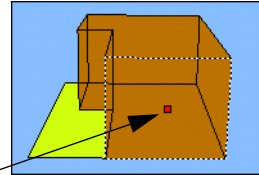

*Construct Average Vertex will mark the averaged center of all included vertices with a temporary construction vertex.*

*When you are done constructing with the vertex tools, you can delete selected construction points with View/Clear Construction.*

## Construct Your First Realtime Model

### *A Classic Farmhouse*

**Step 4** Snap the tracking plane onto the end face with FAC, then click CTR to place the grid center (using the middle mouse!!) exactly on the construction point.

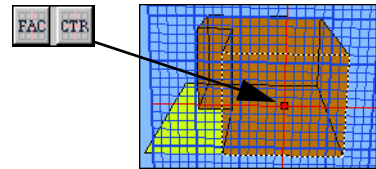

**Step 5** Using the Polygon tool, make a gable triangle. Middle mouse click the end-face upper vertices, and left mouse click the tracking plane for the peak. Use a height of 4 units.

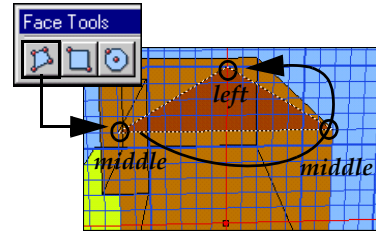

## Make the Other End

### Step 1

With the new triangle selected, Copy (Ctrl+C) and Paste (Ctrl+V). Select the lower right corner of the triangle (using the middle mouse button) as the From point, and again with the middle mouse button, click the far back corner vertex of the house for the To point. Click OK to close the panel.

*From Points and To Points*

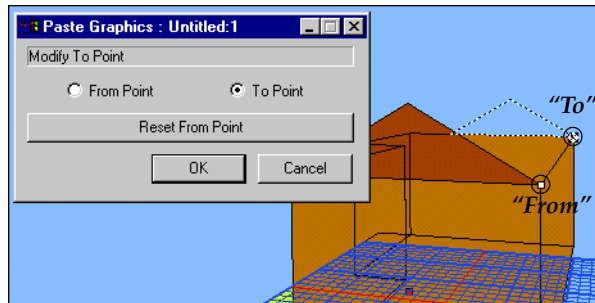

*Many tools calculate a center "From" point for moving a selected object. The From point marks the point on the model that will be placed on the spot that you select as the "To" point.*

*The From point can be offset from the supplied center to a more convenient place on or outside of the object. The "To" point is where you place the object in space.*

## Fix the Wrong Sided Polygon!

The copy of the triangle is facing toward you, rather than toward the other end of the building. From the other end, the triangle would be invisible. To fix the copy, change the direction it is facing by reversing its vertex order:

### Step 1

Make sure the copy of the triangle is still selected, and then select the Reverse Face tool in the Modify Faces toolbox to reverse the order of its vertices (changing its direction).



## Create the Front Gable

### Step 1

Rotate the house so that you are looking at the front of the house again.

### Step 2

Repeat steps 2 through 5 in section, *Creating a Gable*, to create a centered triangle over the front projection.

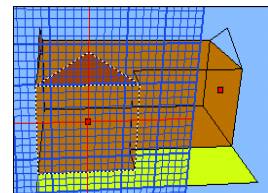

## Raise Gables for Height

With all three gables created, it's time to raise them simultaneously to the same height using a tracking plane offset and the Projection tool. The tracking plane will be offset a specified distance using the original orientation.

**Step 1** Set the modeling mode to Vertex mode (Shift+V).



**Step 2** In the View panel, click the XY grid control to reset the tracking plane to the ground.

**Step 3** Set the Grid Z offset to 20 ft. to prepare for snapping the roof peaks to full height.

*Offsetting the Tracking Plane*

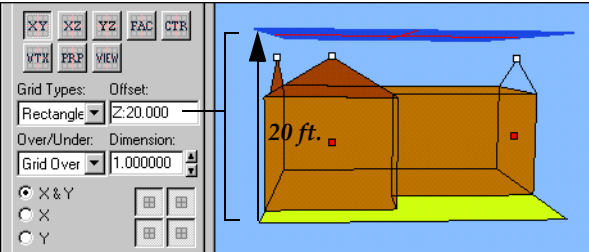
A screenshot of the 'Grid Types' panel in a software interface. The 'Offset' field is set to '20.000'. The 'Grid Over' field is set to '1.000000'. The 'Over/Under' dropdown is set to 'Grid Over'. The 'Dimension' field is empty. The 'X & Y' radio button is selected. The 'X', 'Y', and 'Z' grid icons are visible. To the right of the panel is a 3D view of a brown house with a red roof. A blue horizontal line represents the tracking plane, which is offset from the ground. A vertical arrow indicates the offset distance, labeled '20 ft.'. The house is on a yellow ground plane.

*Offset is useful for a relative displacement of the tracking plane from a known position.*

*Be sure to reset Offset to 0 when done with the offset!!*

**Step 4** Hold down the Shift key and middle-click the three gable tips.

**Step 5** Select the Project tool in the Modify Geometry toolbox to snap the selected vertices straight up to the tracking plane level.

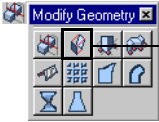
A screenshot of the 'Modify Geometry' toolbox in a software interface. The 'Project' tool icon, which shows a vertical arrow pointing upwards, is selected. An arrow points from the 'Project' tool icon to a 3D view of the house. In the 3D view, the three gable tips are now aligned with the blue tracking plane. The house is on a yellow ground plane.

*Modify Geometry Tools edit the shape of selected objects.*

*Project flattens selected vertices directly to the tracking plane in the Z direction*

**Step 6** Enter 0.0 in the Offset field to reset it!!



## Delete a Hidden Face

Because the top face of the building is a concave face and will soon be hidden from view by the roof, this face should be deleted.

**Step 1** In Face mode, select the "L" shaped top face (only) and delete it with the Backspace or Delete key.

A shortcut is to choose *Select/Select Concave Faces*. This function finds and selects all concave faces for you. Use the Delete key to delete them.

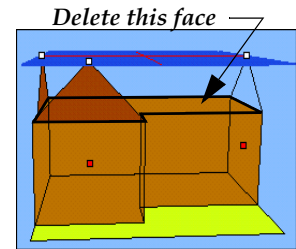

## Make the Long Roofline

Building roofs can be very simple flat faces for flight or distance viewing, or "thick" roofs can be constructed for close up views.

Because this house will be viewed closely from the ground, the roof cannot be a simple flat face. The roof, however, requires some dimensionality. Prepare the hierarchy and tracking plane for the new geometry:

**Step 1** In the Hierarchy view, Alt+click the House node to make it the current parent.

**Step 2** In the Create Tools toolbox, select the *Group* icon to create a new group. Name this group (Ctrl+J) "Roof".

**Step 3** Alt+click the Roof node to make it the current parent.

**Step 4** Using the right mouse, turn the model to look at the right end again.

**Step 5** In the View panel, use FAC and CTR to set the tracking plane onto the centered red construction point as you did earlier.

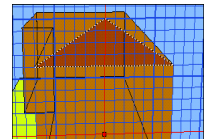

## Make the Roof Cross-Section

**Step 1** Create two polygons to outline the roof cross-section with the Polygon tool. See the illustration below, entering the points exactly as shown:

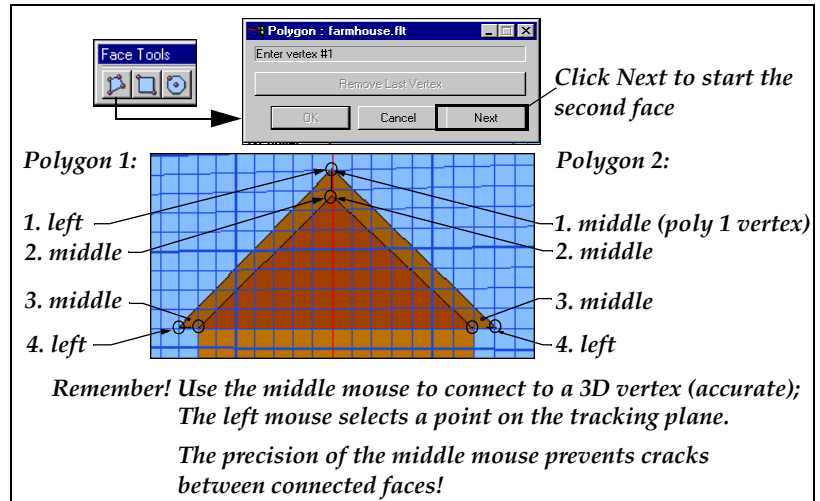

## Extend the Roofline

- Step 1** Select both new faces (Shift+click), and rotate the model slightly so the far end corner of the house is visible.
- Step 2** Select the Wall tool and check the Keep Bottom checkbox. The back end faces will be automatically created.
- Step 3** Middle-click the far end of the building to extend the roof, and then click OK to close the wall dialog box.

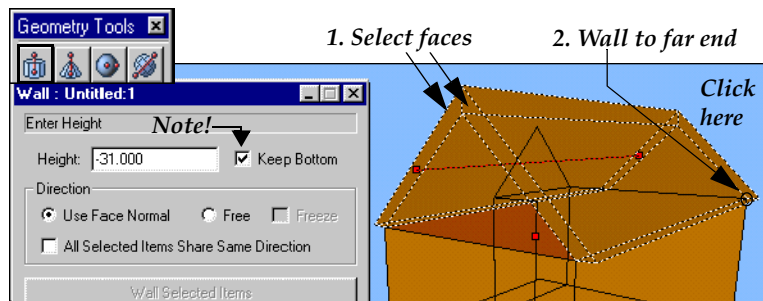

## Create the Overhang

The Scale tool is handy for creating the overhang at both ends of the roof simultaneously by enlarging the roof in the X direction only.

- Step 1** Choose FAC and snap the grid to the top face of the roof (see illustration below). It is easier to scale against a known measure.
- Step 2** Select the Roof group in the Hierarchy view to select all polygons making up the roof.
- Step 3** Open the Maneuver toolbox and select the Scale tool (Shift+S).

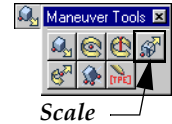

- Step 4** Scale the roof in the X direction to extend the roof out by about a foot beyond the gable, approximating using the slider, or by entering 1.055 in the X multiplier field. Because the scale is centered on the roof, the roof extends in both X directions:

*The Scale tool can be used to rescale in any or all directions by an entered multiplier, slider, or by "pulling" graphics tabs with the left mouse.*

*Use "X" slider to control scale in X axis only*

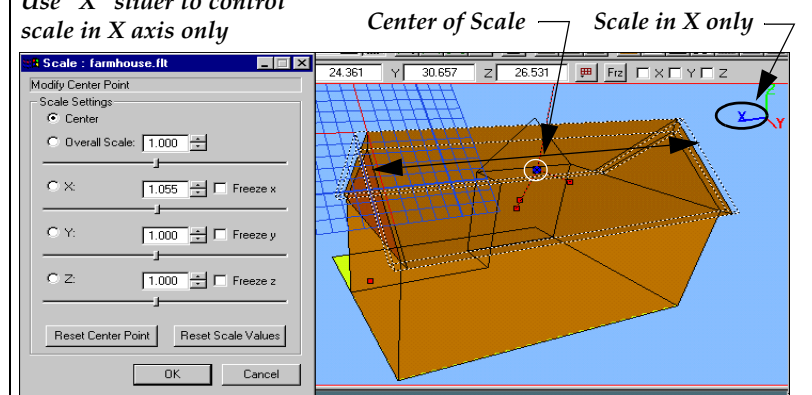

# Construct Your First Realtime Model

## A Classic Farmhouse

### Create the Front Roof Cross-Section

- Step 1** Rotate the house so you are looking at the front.
- Step 2** Create the roof cross-section for the front of the house exactly as before.

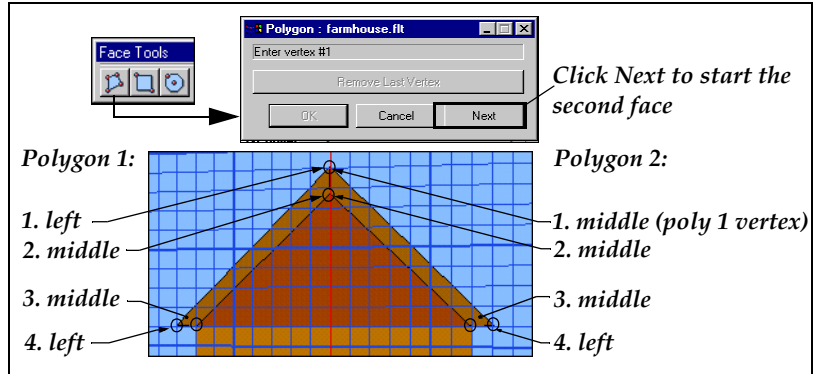

- Step 3** Select the two faces and, using the Wall tool, wall them 1 foot out from the house. Be sure to leave the new faces selected:

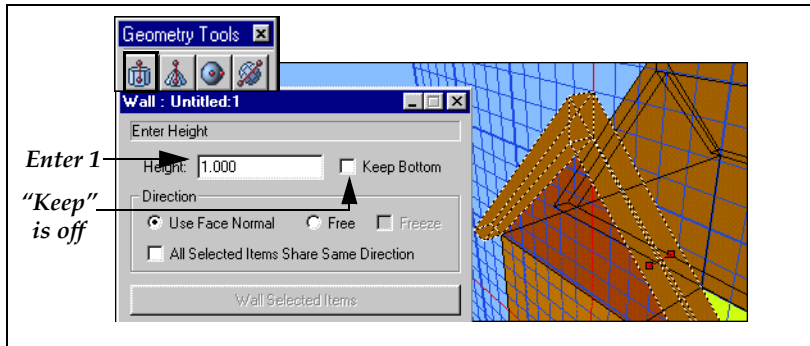

- Step 4** Open the Maneuver toolbox, select the Scale tool (Shift+S), and middle-click on the frontmost peak vertex to move the center of scale to the very front.

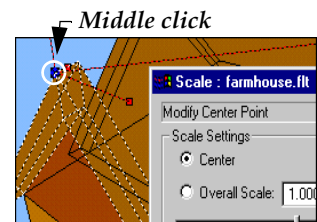

## Extend the Peak

The challenge is to make sure the new roof will fit snugly against the existing roof. By extending the new roof through the existing roof and using the Slice tool to cut the new roof to fit, we get our result. The overlong “excess” roof is easy to select and delete when the slice is complete.

For this step, remember to use the keyboard shortcut *v* to recenter the image in the view, particularly while extending the roof out of view.

**Step 1** In the Scale dialog box, select the Y axis scale, and use the Y slider to extend the roof all the way through and beyond the back of the house (or enter 30 in the Y scale field). Leave the new faces selected.

*Moving the center of scale allowed control over the direction of scaling toward positive Y only.*

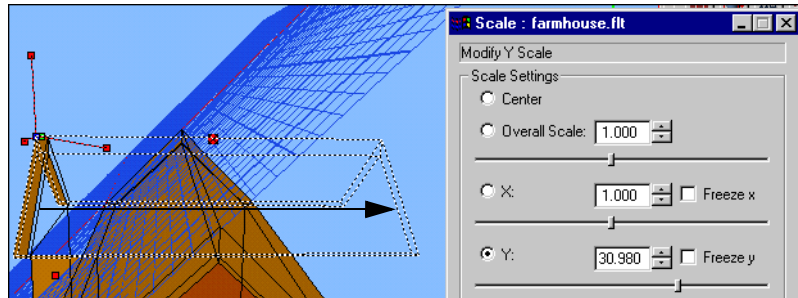

## Slice to Fit

**Step 1** Snap the tracking plane to the long roof face (existing roof) with FAC (see illustration above or below).

**Step 2** In the Geometry Tools toolbox, select the Slice tool to cut the long faces exactly to the angle of the long roof.

*Slice uses the tracking plane as a knife, splitting all selected faces intersecting the tracking plane.*

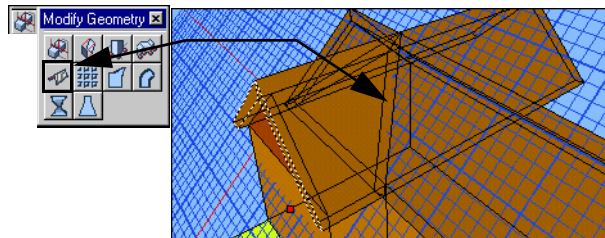

*A soft beep will sound (if you have speakers). Turn off the grid to better see the slice.*

## Cleanup

The roof is essentially complete, except for the removal of unwanted construction scrap. Remove that now:

**Step 1** Select and delete the polygons that extend in the back of the house.

*Use the right mouse to rotate the house for the best view.*

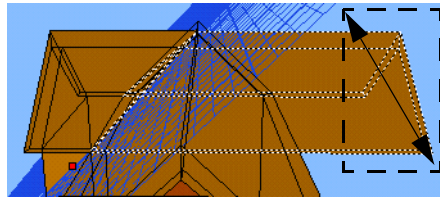

*Using the left mouse, fence select only the end of the extruded roof and delete the faces with the Delete key.*

**Note:** This quicker method of constructing “thick” roof components leaves four interior faces that should be deleted at some point: The two back-to-back interior faces where the halves meet and the underside faces, which can be kept if an interior is required.

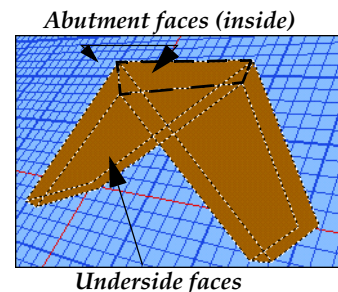

## Remove Construction Points

The red construction points are no longer necessary and can be removed:

- Step 1** Set the modeling mode to Vertex mode (Shift +V).
- Step 2** Click each red construction vertex, or fence select the entire house, selecting all the vertices including the construction vertices.
- Step 3** Choose *Edit/Clear Construction* to remove the construction vertices.
- Step 4** Select Face mode (Shift +F) after clearing the construction points.
- Step 5** Save your file!



## Doing Windows

The use for a model determines the kind of windows you create. At the cost of one face, a wall texture containing a window can be applied to a blank wall that will be viewed at some distance. For close-up “clean” window edges, subfaces can be applied to or “cut into” the wall and a window image texture can be applied to the subface for a cost of two to five faces. Finally, for very close interaction and realism, through-wall windows can be constructed at a minimum cost of 16 faces per window.

This section will concentrate on the creation of the more generally practical subface windows.

For convenience, start with the front wall of the house.

## How to Select the Correct Face in the Hierarchy View

Creating a subface entails selecting a Face node, making it a parent, and creating a new face under it.

**Step 1** Rather than searching for a particular wall by searching the database, simply Alt+click the front face in the Graphics view to set it as a parent. If you also wish to see the Face node in the Hierarchy view, middle-mouse click within the Hierarchy view for the selected face.

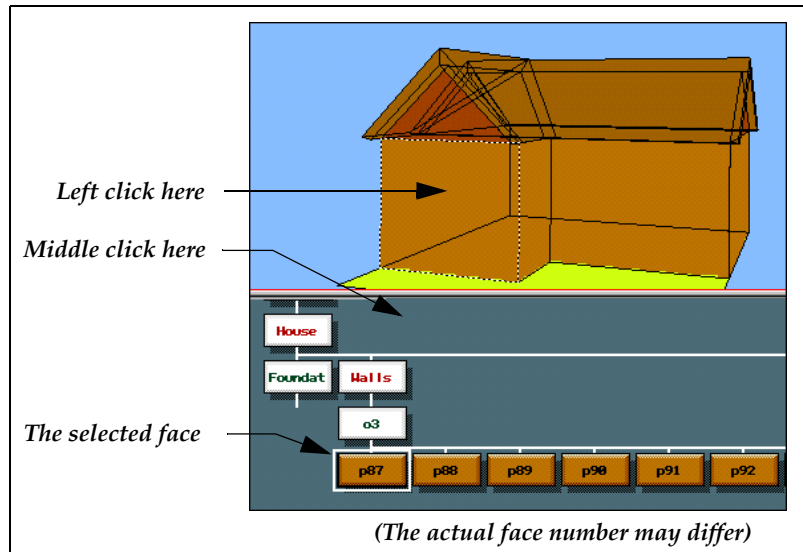

## Making Subfaces

Subfaces are smaller faces within larger faces. Simple subfaces are smaller child faces under larger parent faces. Cut-ins replace the larger single face with triangles surrounding the subface.

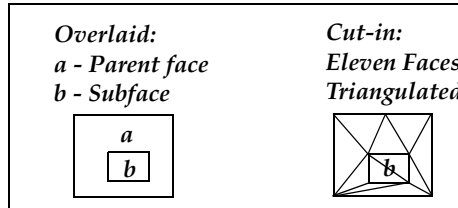

- Step 1** In the View panel, use FAC to snap the tracking plane to the front wall, and CTR to place the center on the lower left corner of the wall (use the middle mouse button).
- Step 2** Select a light greenish color for glass.
- Step 3** With the front face selected and assigned as a parent, use the Rectangle tool to create a window face, placing the lower left point at (4,2) and the upper right point at (9,5). Click OK.

Look very carefully at the Hierarchy view. Note the small rectangle within the Parent node. This symbol indicates the face has a child, or subface.

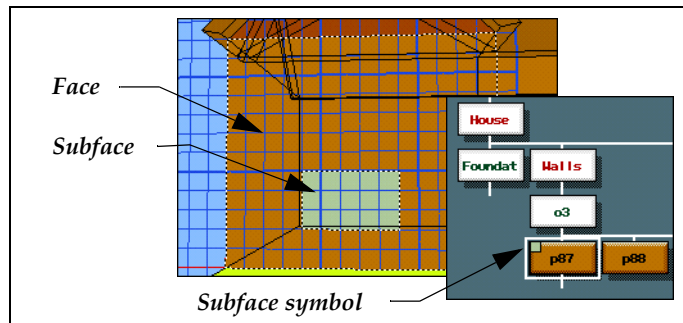

## Cut the Window in!

Child subfaces are not always practical. Not every display system can accept subfaces, and if you wish to make the subface window transparent, the subface must be cut-in.

In Creator, cut-ins simply add two additional steps that replace the parent and child faces with a fully cut-in and triangulated set of faces:

- Step 1**    **Select the parent face.**
- Step 2**    **Choose *Edit/Cut Subfaces*.**

**Note:** The window will be split into two triangles. If you wish to have a solid window (non-triangulated), Shift+click the two faces for the window and choose *Edit/Combine Faces*. The *Combine Faces* option joins two coplanar faces into a single face!

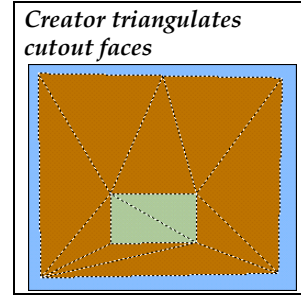

## Your Challenge!

Create the remaining windows and doors around the farmhouse following the same procedures found in sections *Doing Windows* and *Making Subfaces*. Use simple subfaces for the rest of the windows. Be careful about selecting the correct parent face for subfacing.

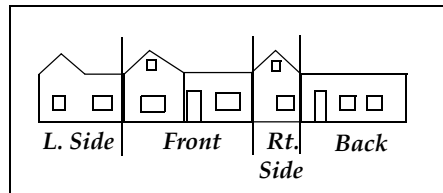

**Note:** As you place the small windows into the gables, the windows may appear to disappear or not get colored correctly because the roof is drawn last and overwrites the upper windows.

For the moment, type **z** on the keyboard to turn on z-buffering to resolve the ordering. Z-buffering is a method to determine the color to paint a pixel if more than one face is drawn in the same area of the screen. Z-buffering is discussed in the next chapter.

## Preparing for the Front Porch

This house only requires a simple front porch roof with three posts, which is an easy addition.

But first, prepare your hierarchy and orient the model for your new construction!

- Step 1** Rotate the house so you are facing the front of the house and looking down on the front porch area (a pitch of 41 is useful).
- Step 2** Snap the tracking plane to the top of the foundation with FAC and center the grid (CTR) to the front left corner of the top foundation face (see illustration below).
- Step 3** In the Hierarchy view, assign the House group node as the current parent (Alt+click on the node).
- Step 4** Create a new group and name it "Porch" (Ctrl+J).
- Step 5** Alt+click on the group Porch to set it as the current parent.
- Step 6** Select Object mode (Shift+O). Each object you create will automatically place its faces under a unique object identifier.

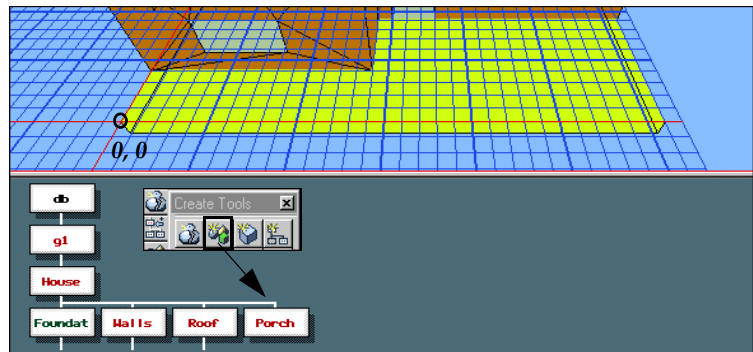

## Make the Posts

- Step 1** Select a color for the porch post.
- Step 2** With the Rectangle tool, create a square face on the tracking plane (0, 0 to 1,1) with the left mouse (see the illustration below).
- Step 3** Select the Wall tool, uncheck the Keep Bottom checkbox, and wall the post to 8 feet, leaving the post selected.
- Step 4** With the post still selected, enter Ctrl+C to copy the post and enter Ctrl+V to paste the copy along the porch.
- Step 5** In the pop-up Paste Graphics panel, select the front-right corner of the original post with the middle mouse button as the From point, and place the To point at (20, 0) with the left mouse button. Leave the second post selected.

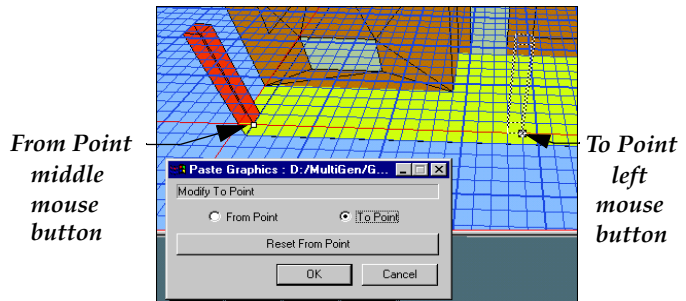

- Step 6** Repeat steps 4 and 5, placing the third post at the front right corner of the porch.

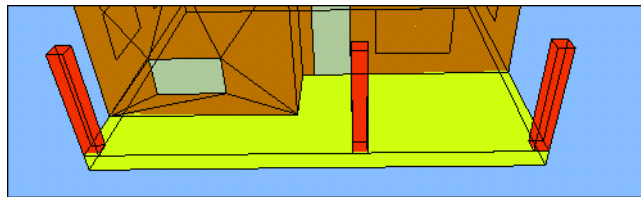

**Create the Porch  
Roof**

- Step 1** Be sure the Porch node is the current parent (Alt+click).
- Step 2** Click the house, type v to re-center the house in the view, and then rotate the house so that the right side is facing you.
- Step 3** Using FAC, snap the tracking plane to the face of the closest post. If necessary, center the tracking plane on the left top vertex of the post, which ensures that the roof sits on the post.

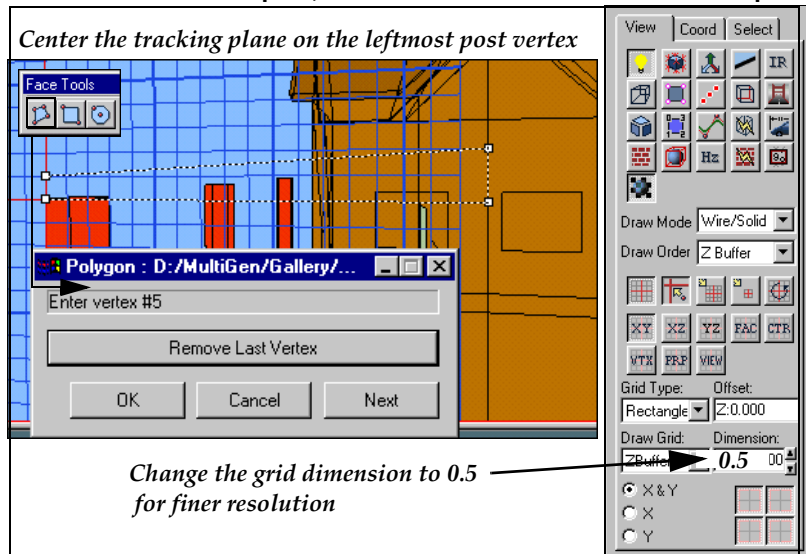

- Step 4** Change the grid Dimension units to 0.5 to work in units of 6 inches.
- Step 5** Use the Polygon tool to outline the roof cross-section as shown in the illustration. Be sure to middle-click the post vertex and left-click the remaining points.
- Step 6** Select the Wall tool.
- Step 7** Check the Keep Bottom checkbox to create the far wall, and then enter a wall height of -31, or simply middle-click one of the far window vertices, which is visible through the wall.
- Step 8** Type v to center the view on the new roof to see the house.



## Construct Your First Realtime Model

### A Classic Farmhouse

**Tip!** The porch roof introduces *interpenetrating* faces which are often used for complex fitting effects without much effort.

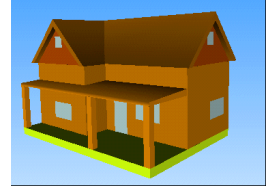

In practice, interpenetrating faces should be used only where necessary, since they both increase the pixel depth (the number of times a pixel is drawn), and require z-buffering to resolve.

## The Chimney

The final touch is the chimney. The challenge is that the chimney must be vertically planted on the roof, with the lower vertices exactly matching the slope of the roof.

Here you can use three new tools: *Revolve about Edge* to lathe the chimney shape; *Rotate about Point* to orient the chimney; and *Plant* to plant the chimney on the roof.

## Prepare the Hierarchy

**Step 1** Assign the House node as the parent and create a new group. Rename the group "Chimney".

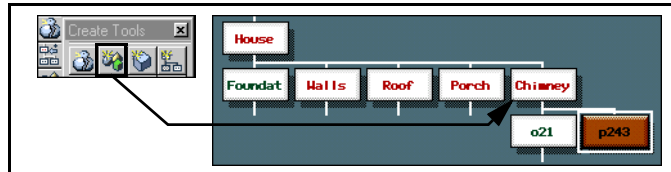

**Step 2** Set the modeling mode to Object mode (Shift+O).

## Position the Tracking Plane

**Step 1** Click XZ in the View panel to snap the tracking plane to the X-Z plane to construct a vertical object.

**Step 2** Click CTR and middle-click the topmost left long roof vertex. The tracking plane will be centered along the roof.

**Step 3** Assign a grid offset of -2.0 to move the tracking plane forward over the roof, where the chimney will be placed.



# Construct Your First Realtime Model

## A Classic Farmhouse

### Step 4 Set the grid Dimension to .5 feet, or 6 inches.

Place the grid here (middle mouse) and offset the grid forward (-2.0)

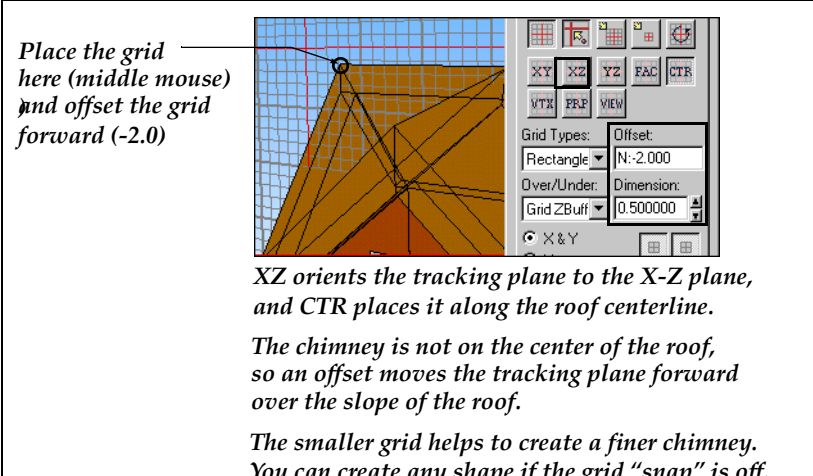

XZ orients the tracking plane to the X-Z plane, and CTR places it along the roof centerline.

The chimney is not on the center of the roof, so an offset moves the tracking plane forward over the slope of the roof.

The smaller grid helps to create a finer chimney. You can create any shape if the grid "snap" is off.

### Make the Chimney

**Step 1** In the Hierarchy view, Alt+click the Chimney node to set it as the current parent.

**Step 2** Using the Polygon tool, outline a half-silhouette of the chimney. Zoom in using Shift+right mouse to access the grid easily. Leave the new face selected:

Polygon Tool

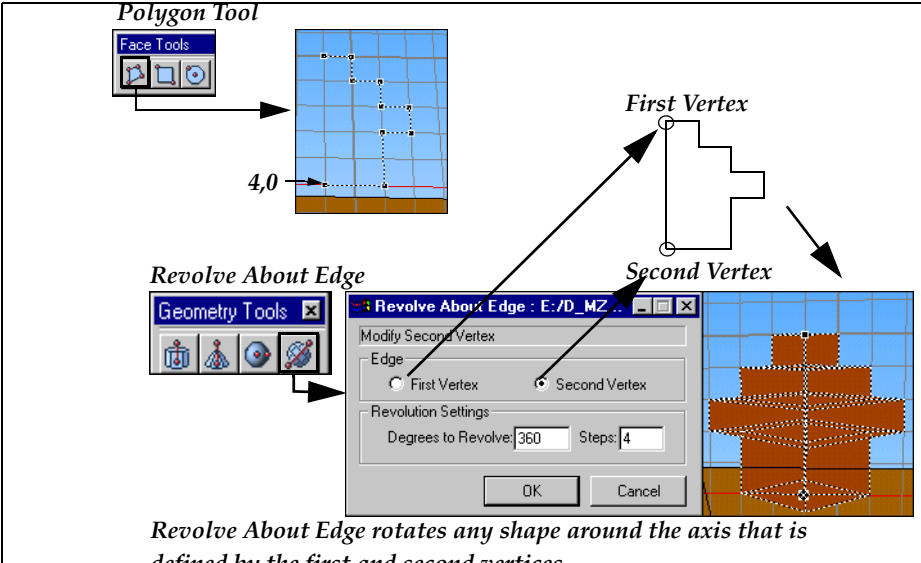

4,0

First Vertex

Second Vertex

Revolve About Edge

Revolve About Edge: E:/D\_MZ...

Modify Second Vertex

Edge

First Vertex  Second Vertex

Revolution Settings

Degrees to Revolve: 360 Steps: 4

OK Cancel

Revolve About Edge rotates any shape around the axis that is defined by the first and second vertices.



- Step 3** Type Ctrl+J and rename the new face "remove" as a reminder to discard the face after the next two steps. Leave the face selected.
- Step 4** Select *Revolve about Edge* in the Geometry Tools toolbox. Set the First Vertex option and middle-click the upper left vertex point, as shown in the illustration above. Set the Second Vertex option and middle-click the lower left vertex to define the edge.
- Step 5** Enter a rotation of 360 degrees and set the number of sides to 4. Click OK, and leave the chimney selected.

## Cleanup

- Step 6** Select the original profile face of the chimney in the Hierarchy view and delete it to remove the hidden face.

**Tip!** It is a good idea to remove construction points and hidden construction faces as soon as they are no longer needed. Final model cleanup becomes a great deal easier when you are not concerned with finding unneeded or hidden leftovers.

All that is left to do is rotate and plant the chimney on the roof!

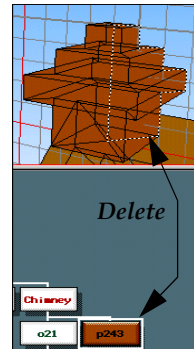

## Rotate the Chimney

The **Maneuver Tools/Rotate About Point** tool is used to rotate selected geometry around a center point placed anywhere in space. The tracking plane controls the plane of rotation.

- Step 1** In the View panel, click XY to reset the tracking plane, and then center it on any low vertex of the chimney with CTR.
- Step 2** Make sure the chimney is selected. If it is not selected, select its node in the Hierarchy view to select all the chimney faces.

## Construct Your First Realtime Model

### A Classic Farmhouse

- Step 3** Choose Rotate About Point in the Maneuver toolbox. Set the Rotation option, and either rotate the chimney 45 degrees using the up/down arrows to change the value in the field or rotate the clock dial, and then click OK. Leave the chimney selected:

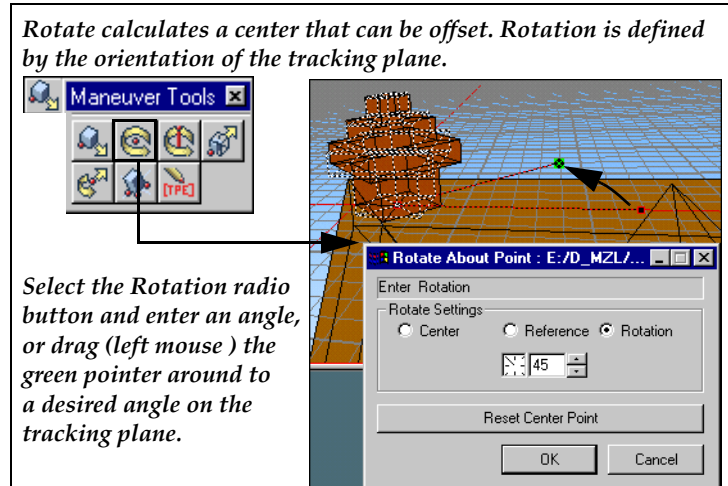

## Plant the Chimney

- Step 1** Snap the tracking plane to the front-facing long roof with FAC.
- Step 2** Select the chimney.
- Step 3** Select *Plant* in the Modify Geometry toolbox to plant the chimney onto the roof:

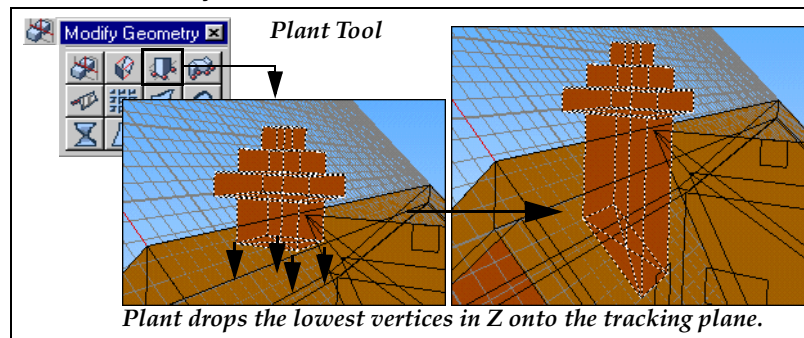

- Step 4** Save your model! You now have a farmhouse!



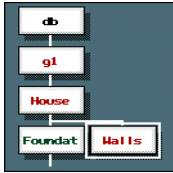

## Structuring a Database Hierarchy

### Introduction

Besides being visually appealing, you also want your model to display correctly in the runtime system. The parts of a model are represented as nodes in a database hierarchy. The runtime system traverses through the hierarchy to display your database components. A well-structured hierarchy ensures that your model displays as you intend at the highest possible speed in the runtime system.

In this chapter, you will learn how to structure and edit an efficient database hierarchy using the Creator graphical interface.

### Contents

<b>THE BASICS</b>	74	Node Attributes	79
		Challenge	81
<b>HIERARCHY VIEW</b>	74	Fixed List Ordering	82
<b>PROPER DATABASE STRUCTURING</b>	75	Z-buffering - An Alternative to Polygon Order	82
<b>WORKING WITH THE DATABASE STRUCTURE</b>	76		
Expanding/Contracting the Structure	76		
Creating Empty Nodes	77		
Selecting Nodes for Editing	77		
Moving Nodes to New Parents	78		
Shifting the Order of Nodes with Siblings	79		
Finding Nodes	79		

## *The Basics*

### **Hierarchy View**

The Hierarchy view shows you the organizational structure of your database components. The components are arranged in levels of nodes connected in one or more tree structures. You can click or select-and-drag nodes with your mouse to edit them in the Hierarchy view.

The Hierarchy view is also a visual data structure editor with the following:

- **Your evolving structure displayed**
- **Point-and-click graphic re-editing of database components**
- **Double-click access to all attribute information and editing**
- **Special effects, such as articulation, lights, and sound clearly displayed**
- **Graphical representation of object and face drawing order**



## Proper Database Structuring

Beginning with the database (*DB*) node, your general database structure should follow this order:

<i>DB Node</i>	Contains descriptive information about the entire database itself. Only one DB node can be at the top of the structure.
<i>Master Groups</i>	A master Group node ( <i>g1</i> or <i>g2</i> ), represents the entire model. All component hierarchies are ultimately attached to this common point. Creator provides <i>g1</i> and <i>g2</i> for you.
<i>Significant Groups</i>	A number of Group nodes, each representing major components of your database. For example, an airport might have significant Group nodes for <i>Runway</i> , <i>Bldg1</i> , and <i>Bldg2</i> . Complex models can have several levels of significant groups.
<i>Objects</i>	Objects can only contain Face nodes (polygons), and are used to mark single objects with no moving parts. For example, an Object node named <i>Rock</i> would contain only those faces making up one rock.
<i>Faces</i>	Face nodes are easily recognized because they are always drawn in the color of their respective face as viewed in the graphic model. Faces can be attached to groups, objects, or other faces becoming <i>subfaces</i> .
<i>Vertex</i>	Vertex attributes are characteristics of face attributes and have no hierarchal significance.

It is important to note that the order shown here also indicates how nodes can attach to one another. The only rules of hierarchy to note are:

- **Group nodes can have anything attached to them**
- **Object nodes can only have faces attached to them**



## Working with the Database Structure

Creator inherently constructs the database structure each time you add any graphical item to the model. This structure will be a very confusing one, however, reflecting more the order in which you created and edited your model than what you intended it to look like.

The first task is to look at what you have and then fix it if necessary. Be sure to try each of the following examples with the farmhouse model as you read on in the chapter.

### Expanding/ Contracting the Structure

In a complex model, the structure can be very large, so it is important to have control over how much and what is shown in the Hierarchy view at any time. Look at the farmhouse structure and try this (if your structure doesn't exactly match, you'll fix it soon):

*A node tail indicates there is more under it*

*Middle mouse expands the structure of a selected node downwards; each click expanding more levels*

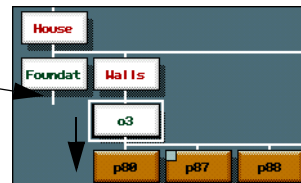

*Alt+middle mouse retracts the structure of a selected node upwards; each click retracting another level*

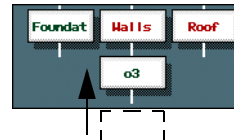

## Creating Empty Nodes

Empty Group or Object nodes are often created to define the structure, and then geometry is later added to them. To create empty Group and Objects nodes, do the following:

- Select an appropriate parent (Alt+click the node).
- Select the Create tools palette.
- Click the Group or Object Create node button.
- Rename the node to something meaningful (Ctrl+J), or choose *Attributes/Rename*.
- Set the new node as parent (Alt+click the node), or click the Parent button.

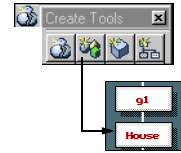

## Selecting Nodes for Editing

To edit nodes, you can select nodes singly, in groups, or in additive groups in the Hierarchy view. You can even select nodes by selecting their image in the Graphic view. Within the Hierarchy view, try each one of the following options:

- Click a node to select one node using the left mouse button.
- Fence select across several sibling nodes by holding down the left mouse button and dragging across them.
- Hold down the Shift key and click or drag across unrelated nodes. If a parent is already selected, you cannot additively select one of its children, which is already selected with the parent.
- Use Shift+click to deselect nodes that are mistakenly selected without losing other selected nodes.

## Moving Nodes to New Parents

Once selected, you can drag either nodes or groups of nodes with the left mouse button from parent to parent at any time within the rules of hierarchy.

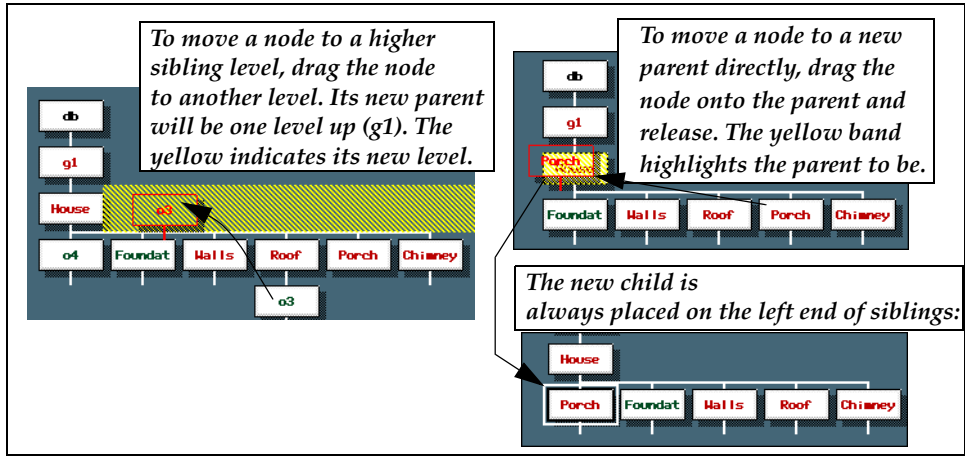

## Attach

In large and complex databases where scrolling is not practical, you can move nodes to a new parent with the Attach hierarchy tool.

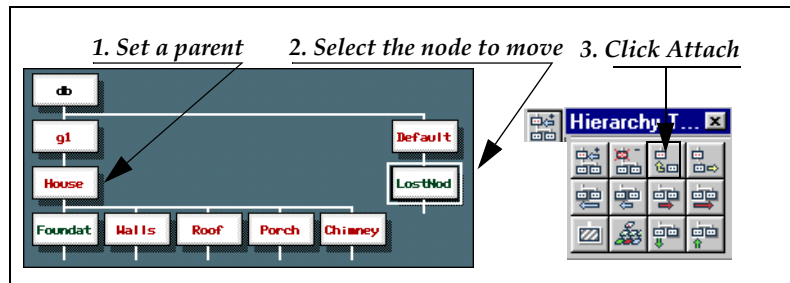

## Beware of Detached Nodes!

Nodes can be dragged and dropped onto the background of the Hierarchy view, essentially detaching them from the hierarchy. Nodes that are left detached have no parent. Detached nodes are not saved with the database and are lost!



## Shifting the Order of Nodes with Siblings

Faces under a group or object are drawn from left to right. If parts of your model are drawn in the wrong order in the Graphics view, you can shift the order of nodes to the left or right to change the drawing order. You can also change the order of nodes to group faces of a common color to reduce switching time (state changes) on your image generator.

For node shifting, use the Hierarchy/Shift buttons for the following:

- **Select one or more sibling nodes**
- **Shift Left** moves the selected nodes one position to the left
- **Shift Right** moves the selected nodes one position to the right
- **Shift Far Left** moves the nodes to the far left of the siblings (to be drawn first)
- **Shift Far Right** moves the nodes to the far right of the siblings (to be drawn last):

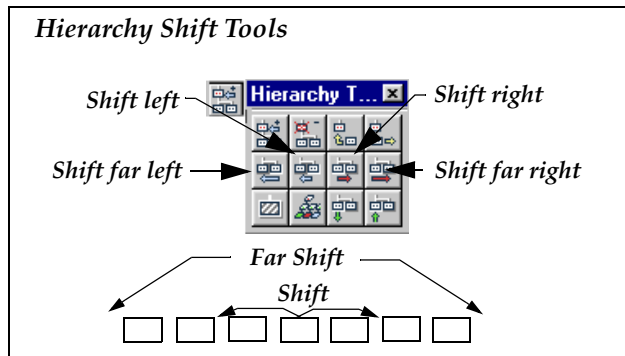

## Finding Nodes

Before you can move or shift nodes, you must find them. In large databases, a node or group of nodes can be deeply buried in layers of structure. Searching for these nodes is nearly impossible.

A much better way to find a node is to select its graphic representation in the Graphics view and click in the Hierarchy view with the middle mouse button. The structure will be expanded and zoomed to your selected object, and the selected node will be highlighted for you.

## Node Attributes

### What is an Attribute?

Every hierarchical node contains information about itself called *attributes* that can be changed or set with various tools.

## 4 Structuring a Database Hierarchy *Working with the Database Structure*

Attribute panels are very useful when wondering, “what color, material, or texture index is used for a face or object?”

### How do I Find Node Attributes?

Select any object or node in either the Graphics view or the Hierarchy view, and type **Ctrl+ =**. You can also simply double-click on any node or graphics object.

*Double click any face and its attribute panel is displayed*

*Global Modify - if selected, a change to this face affects all other selected faces as well*

*Object Name (ID)*

*Each tab reveals color, drawing, or other special fields. You can use the Comments field to imbed special code or controls for your image generator*

*The DB Navigator makes it easy to move through the hierarchy. Each button moves you to the attribute panels of objects above, below, or to either side of the current object*

*Current object, and a display of it*

The image displays two screenshots of the 'Face Attributes' dialog box for object p160. The top screenshot shows the 'Colors' tab, which includes fields for Primary Color (Index: 58239, Name: 58239, Intensity: 1.000000) and Alternate Color (Index: -1, Name: n/a, Intensity: 1.000000). It also has sections for Texture Attributes (Base, Detail, Mapping) and Material Attributes (Index). The bottom screenshot shows the 'DB Navigator' tab, which features buttons for navigating through the hierarchy: SuperFace, Object, Prev, Current, Face, SubFace, Vertex, and Attribute. A 3D preview window on the right shows a blue plane with a black arrow pointing to it.



**Challenge**

With your knowledge of the database structuring tools, rearrange the house database from what you have to the structure shown below. Be sure all faces are under their appropriate object or Group nodes, and the order of groups matches the order shown here.

You might have to create an Object node under the Roof group and then select and move the roof faces under the Object node. Remember to use the Attach option for this.

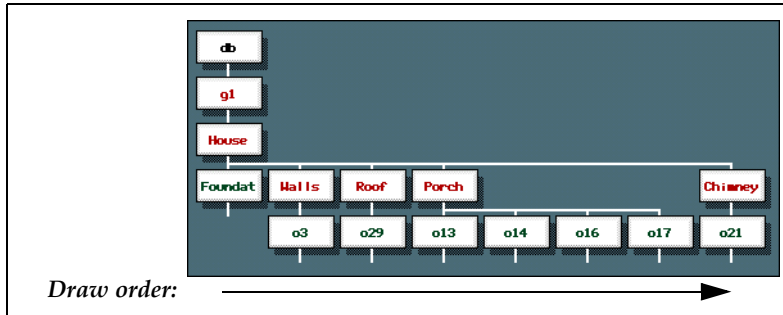

While moving nodes, you might have noticed your graphic image changing in odd ways. MultiGen Creator draws the faces using *fixed list ordering* by default to determine the order in which faces are drawn. The last faces drawn appear to be on top.

What is a fixed list? Turn the page!

## Fixed List Ordering

Ordering your structure for a correct visual result is called *fixed list ordering*, which is the default method. In fixed list ordering, it is important to remember that a model is drawn from left to right, and bottom up.

If your roof looks strange, the roof faces are drawn in the wrong order. Use the shifting tools within the Roof object to move faces that should appear on top to the right of their siblings. The right-most face is drawn last and on top.

**Tip!** You can simply select the faces in the Graphics view and shift them in the Hierarchy view!

## Z-buffering - An Alternative to Polygon Order

Fixed list ordering cannot resolve all possible ordering problems, particularly if one thing protrudes through another. An alternative to fixed list ordering is to view the model in Z-buffer mode by entering *z* on the keyboard. The Z key toggles between fixed list and Z-buffer viewing.

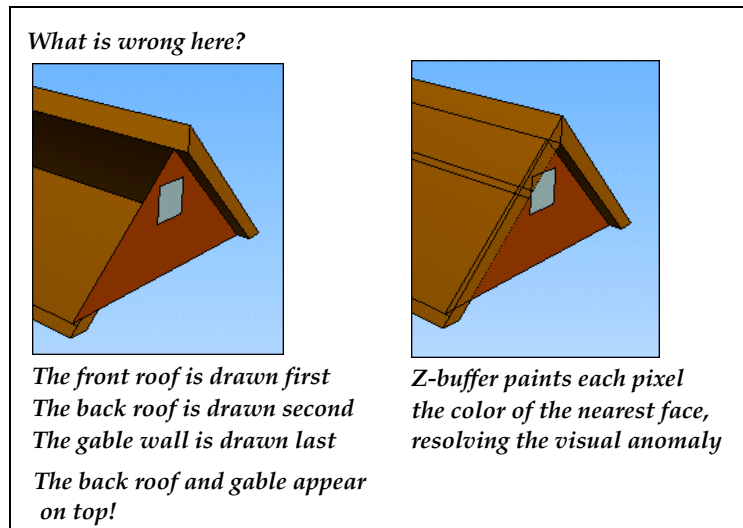

For each pixel, Z-buffering calculates a distance between the screen and everything being drawn in that pixel area. The color of the nearest object drawn is loaded into the pixel, preventing the need to sort or order polygons for drawing.

Z-buffering is great for resolving visual anomalies while editing, but a good structure is what you want to give to your image generator!



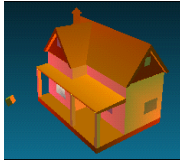

## *Lighting and Shading*

### Introduction

The model constructed so far is flatly colored, and not generally shaded, giving the model a highly unreal look; perhaps even ugly. You can give mood and definition to the objects of your world through the use of lighting and shading effects which can be applied and previewed in Creator.

In this section, you will use Creator lighting and shading tools to enhance your model with lighting effects. At the end of this session, you will be able to position ambient lighting, place local light sources, and specifically locate and orient spotlights anywhere in your model.

### Contents

<b>LIGHTING AND SHADING</b>	88	<b>CREATING A LOCAL LIGHT SOURCE</b>	99
Displaying Shading Effects	89	Characteristics to Note	99
The Four Shades	90	Adding Local Lights to the Database	100
Calculate Shading	91	Important Preference	100
<b>LIGHT SOURCES</b>	93	<b>CREATING A SPOTLIGHT SOURCE</b>	102
Important!!	93	Spotlight Characteristics	102
<b>LIGHT SOURCE PALETTE</b>	94	Adding Spotlights to a Database	103
Modeling Lights	95	Attributes Related to Spotlights	104
Modeling Lights	95	Placing and Orienting Light Sources	105
<b>CREATING AN INFINITE LIGHT SOURCE</b>	97	Create and Position a Spot Light Source	106
Characteristics to Note	97	<b>INTERESTING OPTIONS</b>	107
Adding Infinite Lights to the Database	98	Nightlife Models	107
Attributes of Interest	98	Fog and Fog Controls	107

## *Lighting and Shading*

Shading defines and highlights the shape of objects within the model scene. The shading algorithm used can also modify the appearance of the graphics model, making it appear more complex than it really is.



In the model above, the objects are very coarse in their construction, but Gouraud shading and the placement of two light sources and a modeling light enhance the apparent surfaces of the images.

Creator creates shading effects using a combination of:

- **Three light source types: Infinite, Local, and Spot, which can also be modeling lights**
- **Four shading options for each face: Flat, Lit, Gouraud, and Lit Gouraud**
- **A Lighting mode: "L" activates/deactivates scene lighting**

and

- **Individual models or model components can be independently shaded or lighted in a different fashion from its neighbors**



## Displaying Shading Effects

Creator shading effects are activated when the Lighting mode is active. This is indicated by a capital **L** displayed in the upper left corner of the Graphics view. Lighting mode is toggled on or off by entering **L** on the keyboard, or by choosing *Lighting On/Off* in the View panel.

If you want Creator to automatically activate the lighting mode, set the *Lighting On* check box in the *Info/Preferences/State* panel:.

*Activate lighting with the L key. Lighting mode is indicated in the Graphic view*

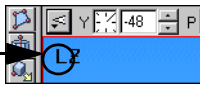

*Lighting On preference can be checked if you want lighting on by default*

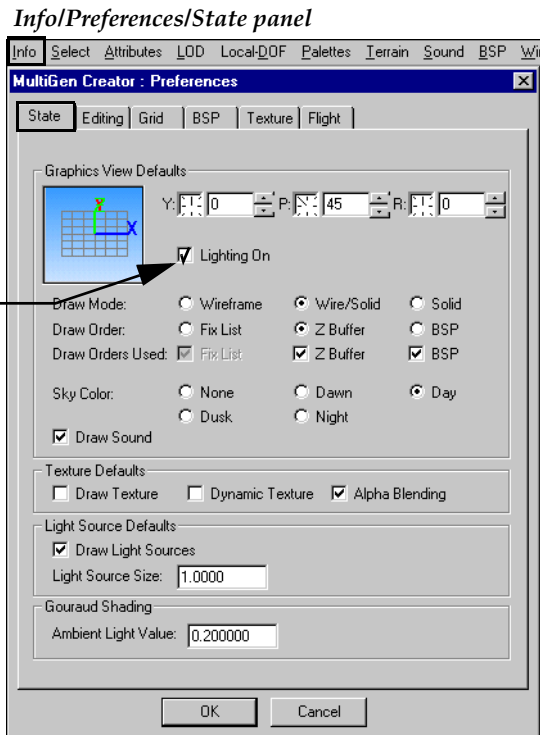

*Draw Light Sources Displays local and spot light sources as cubes that can be precisely placed*

*Gouraud Shading The Ambient Light Value raises the overall Gouraud shading intensity. Use values between 0.0 and 0.3. A value of 1.0 washes out the scene*

When activated, lighting applies up to eight light sources to all or parts of the scene depending how lighting is assigned and constructed in the hierarchy.

For the remainder of this section, be sure the **L** indicator is displayed in your Graphics view. If it is not, toggle it on with the **L** key.

## The Four Shades

Although you can apply shading in any modeling mode, shading actually occurs at the face and vertex levels of your models. Shading is applied to selected faces when you choose **Attributes/Calculate Shading** unless nothing is selected. When no faces are selected, shading is applied to all the faces in the database (when the default Editing preference **Shade All When Nothing Is Selected** is set).

Creator supports the following four types of shading:

<i>Flat</i>	No shading. Faces are displayed only with their assigned colors.
Advantage	No overhead associated with shade computations.
Disadvantage	With wireframe off, the models appear flat and lifeless. Curved surfaces are monotonic with indistinguishable features.
<i>Lit</i>	Each face is shaded uniformly with a lighter or darker shade of color based on its angle relative to any light sources and the blending of face, light source, and material effects.
Advantage	Lit Mode is useful for prototyping lighting effects. Shading is recalculated dynamically.
Disadvantage	Performance is reduced by the calculation overhead of the combined effects.
<i>Gouraud</i>	Each face vertex can be assigned a unique color by using vertex mode and insert color, which is then interpolated across the face. Gouraud shading is always displayed.
Advantage	Gouraud is a smooth shading technique useful for making round faceted shapes appear smooth. Multicolored vertices produce interesting effects.
Disadvantage	Materials are not displayed on Gouraud faces.
<i>Lit Gouraud</i>	Light source colors and intensities contribute to Gouraud shaded surfaces.
Advantage	Multicolored Gouraud faces are affected by light sources, allowing Gouraud surfaces to change shade when moved relative to a light source.



Disadvantage Materials are not applied to lit Gouraud faces.

## Calculate Shading

The key to applying shading in any form is the **Attributes/Calculate Shading** (Ctrl+G) option, which calculates normals for selected or all faces and assigns one of the four shading types to each face.

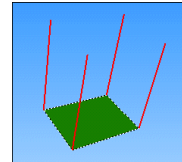

Vertex Normals

All *Lit* lighting effects depend upon each face having vertex normals, which are not automatically calculated and added to new geometry. When creating new geometry, it is a good idea to generate the required normals with Calculate Shading.

To better illustrate shading, light your farmhouse living room.

**Step 1** Open the model *parlor.flr*. For Windows, this file is in the *\Program Files\Multigen-Paradigm\resources\tutorials\creator\DesktopTutor\Models* directory. For IRIX, it is in *usr/local/MultiGen-Paradigm/resources/tutorials/creator/DesktopTutor/Models*. Make sure nothing is selected.

**Step 2** Type L to turn on Lighting mode if it is not already active.

**Step 3** Choose Attributes/Calculate Shading or type Ctrl+G.

*Calculate Shading Dialog Box*

*Update Vertex Normals calculates and sets new vertex normals for each selected face*

*Update Vertex Colors recalculates and sets new vertex colors for each selected face*

*Assigns each selected (or all) faces the selected lighting mode*

*Be careful to keep Update Vertex Colors and Update Vertex Normals off for Gouraud shaded faces with hand entered vertex colors. Your hand entered colors will be lost!*

## 5 Lighting and Shading

### *Lighting and Shading*

**Step 4** Choose the Lit shading model.

**Step 5** Make sure Update Vertex Normals and Update Vertex Colors are both checked, and then click OK. Your living room looks somewhat different!

**Step 6** Save your work, and leave *parlor.flt* open. You will need it to complete the rest of the exercises in this chapter.



## Light Sources

Creator supports individual light sources. These are independently positioned in space and have radiant qualities that affect other objects in the model. You can define any number of light sources, but only the first eight applied can be previewed in Creator.



The image above shows each kind of light source supported by Creator: Wall sconce spot lights, a local lamp light, an infinite light source for general lighting, and a modeling light for enhancing viewing. The window light beams are simply shaded polygons.

- **Infinite light**      **A general light source infinitely far away, such as the sun, causing the light rays to be applied in parallel.**
- **Local light**      **A local light source radiates in all directions from a point in space.**
- **Spot light**      **A local light source with a specific direction and focus.**
- **Modeling lights**      **Any light source that is designated as a modeling light. Its color is applied as if it originates from the eye.**

### Important!!

Light sources act on face vertices, normals, and colors. For radiant lighting effects against walls, such as a candle near a wall, you must split the wall into four or more smaller faces to create vertices close enough to the light source to get a radiant effect.

## Light Source Palette

The Light Source palette contains the light source descriptions of any number of infinite, local, and spot lights. Infinite, local and spot lights are defined in the Light Source palette and are activated and controlled using Light Source nodes.

**Light Source Palette**

Single Click!

Double-click to edit

**Modify Light Source Fields**

**Light Activated for Modeling**  
*Blends the color of the light source with the entire scene. Be careful, this could wash out bright areas*

**Infinite**  
**Local**  
**Spot** } *Select the nature of the light source*

**Azimuth**  
**Elevation** } *Orientation controls for infinite lights*

**Cutoff Angle**  
**Dropoff** } *Controls spot light cone radiance and edge intensity drop off*

**Ambient**  
**Diffuse**  
**Specular** } *Controls the ambient lighting intensity, the light source color, and a specular highlight color*

*Any number of light sources can be created, but only the first eight applied can be viewed in Creator*

**Modify Light Source panel**

**Attenuation**  
**Constant**  
**Linear**  
**Quadratic**

*Attenuation is the light intensity drop-off relative to distance. Attenuation effects are not displayed, but values are retained in the DB*



## Modeling Lights

Light Activated for Modeling creates an additional radiant light source that originates from the eyepoint to brighten your view of the model from various angles. Ambient, diffuse, and specular characteristics defined in the *Modify Light Source* window are applied.

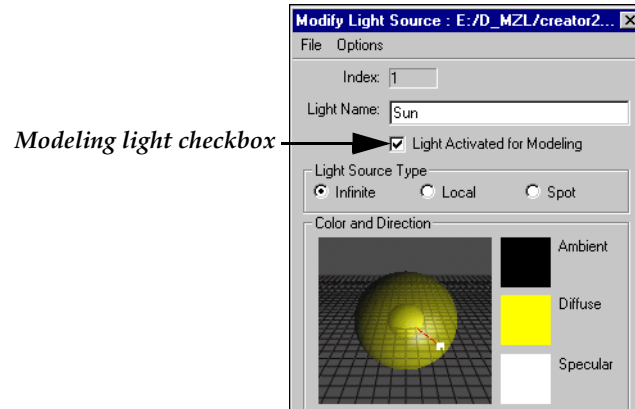

Note the following:

- **Modeling lights are not added to the hierarchy as nodes.**
- **Local or spot light sources with Light Activated for Modeling set contribute their local colors to the more ambient effects of a modeling light and over the objects they directly affect.**

**Beware!** Use some care with modeling lights. Bright modeling lights can easily wash out the colors of your models to white.

**Tip!** For localized lighting effects, keep modeling lights off for all light sources, or use a single low-intensity infinite modeling light to add a soft intensity to the general scene.

Creator defines and applies an infinite modeling light source when Calculate Shading with Dynamic Lighting (L) is executed. The file *parlor.flt* should be open and active.

## Modeling Lights

- Step 1** Make sure dynamic lighting mode is on (L is displayed in the upper left corner of the screen).
- Step 2** Open the Light Source palette.
- Step 3** Double-click the first light (index 1) to open the Modify Light Source window, and move the panel to the side of the screen.

## 5 Lighting and Shading

### *Light Sources*

- Step 4** Be sure the *Light Activated for Modeling* check box and Infinite radio button are selected.
- Step 5** Click the Ambient, Diffuse, and Specular color buttons to change their colors. Select a bright yellow for the Diffuse color, black for Ambient, and White for the Specular highlight.
- Step 6** In the Modify Light Source window, note the vector drawn in the color sphere. Point to the vector with the mouse, and while holding down the left mouse, drag the vector around the sphere. Watch your model each time you release the mouse.
- Step 7** Leave the vector oriented where the model looks the best.
- Step 8** Set and clear the *Light Activated for Modeling* check box. Note its strong effect on the model. Remember: More than one bright modeling light will wash out your scene.

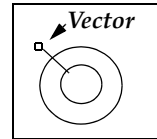

*Not seeing any effect?* Be sure you have used Calculate Shading (**Ctrl+G**) to generate normals for the model faces, and that you are in Dynamic Lighting mode (L).



## Creating an Infinite Light Source

Infinite lights (when modeling lights are turned off) create a general lighting effect over the entire world or a subset of it much like the sun. Light energy radiates uniformly and in parallel from a single direction and infinite distance.

Infinite light sources are defined in the Light Source palette by selecting the type *Infinite*.

*Infinite Light Source*

Light Source Palette: E:/D\_MZL/cr...  
File Edit View

Modify Light Source: E:/D\_MZL/creator2...  
File Options

Index: 1  
Light Name: Sun  
 Light Activated for Modeling

Light Source Type  
 Infinite  Local  Spot

Color and Direction

Ambient: [Black] Diffuse: [Yellow] Specular: [White]

Azimuth: 30 Elevation: 180

Spot Cone  
Cutoff Angle: 30.31 Dropoff: 0.00

Spot Attenuation  
Constant: 1.00 Linear: 0.00 Quadratic: 0.00

Turn modeling light off

Select Infinite

Orb Vector

Ambient color contributes to overall scene radiance. Keep this dark to avoid washout

Diffuse color is the light source color itself

Specular is the color of the highlight on shiny surfaces

## Characteristics to Note

Because infinite light sources are located in space and radiate on objects with parallel rays, they only need to be assigned ambient, diffuse, and specular color characteristics.

The *Azimuth* and *Elevation* dials set the location of the infinite light source in space relative to the center of the world and are changed either directly or by dragging the *Orb vector* around. Be sure to watch the scene as you drag the Orb vector to get the right effect.

## Adding Infinite Lights to the Database

Light Source nodes represent light sources in the database hierarchy, as shown in the illustration below. By adding light sources to the database as nodes, you have more control over their effects.

Use the Create Light Source tool to create Light Source nodes under any Group node.

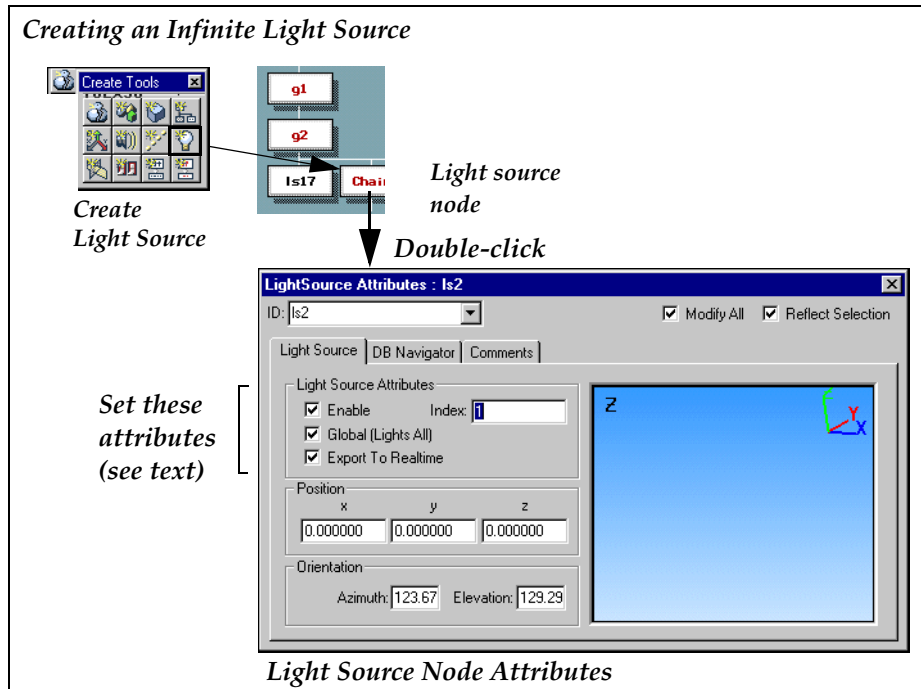

## Attributes of Interest

### *Palette Index*

The Palette Index contains the index of a light source defined in the Light Source palette, in this case, Palette Light Source 1.

### *Enable*

Enables (turns on) or Disables (turns off) the light source and its effect in the database.

### *Global (Lights all)*

The light source radiates onto all objects. If not set, only the children of the Light Source node are illuminated by this light.

### *Export to Realtime*

Indicates this light source should be included in an exported database.



## Creating a Local Light Source

Local light sources radiate light uniformly in all directions from a specific location in space, not unlike an open candle flame or naked light bulb. The characteristics of a local light source are defined in the Light Source palette.

Local light sources must have a database node added to the hierarchy which contains its  $x$ ,  $y$ ,  $z$  location in space.

You define local light sources in the Light Source palette by selecting the Local option button.

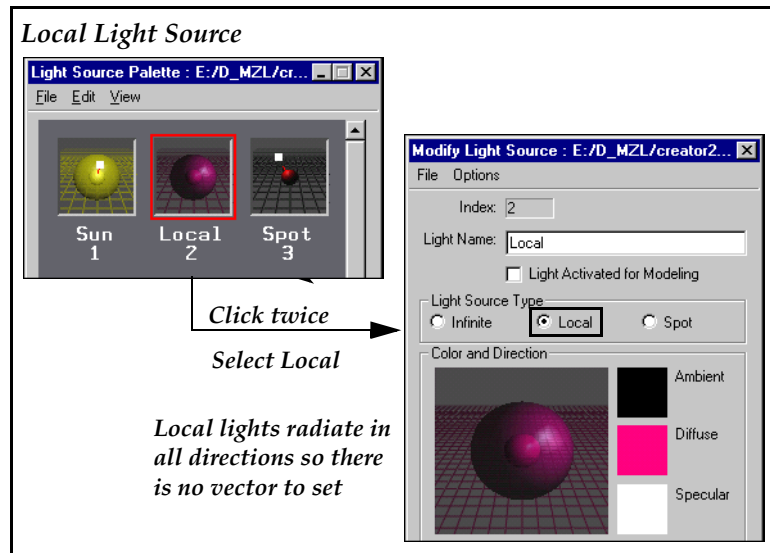

## Characteristics to Note

Because local light sources are located in space and radiate in all directions, local light sources only need to be assigned ambient, diffuse, and specular color characteristics.

**Adding Local Lights to the Database**

Local light sources are represented in the database hierarchy by a Light Source node, shown in the following illustration, and graphically with a light source cube that can be positioned anywhere in world space.

*Creating a Local Light Source*

*Create Light Source*

*Light Source node*

*Double-click*

*Radiates in all directions*

*Light source cube*  
*Use Place Light Source or Translate to position*

*Light Source Node Attributes*

**LightSource Attributes : Local**

ID: Local  Modify All  Reflect Selection

Light Source | DB Navigator | Comments

Light Source Attributes

Enable Index: 2

Global (Lights All)

Export To Realtime

Position

x	y	z
-20.000000	-20.000000	0.000000

Orientation

Azimuth: 128.33 Elevation: 119.00

LZ

*Light Source Cube*

**Important Preference**

Light sources are invisible points that radiate light. For placing lights, select *Draw Light Sources* in the View panel to draw a representative light cube at the light source's position in space. Use the file *parlor.flt* to complete this exercise. For Windows, this file is in `\Program Files\Multigen-Paradigm/resources/tutorials/creator\DesktopTutor\Models` directory. For IRIX it is in `/usr/local/MultiGen-Paradigm/resources/tutorials/creator/DesktopTutor/Models`.



- Step 1** In the Light Source palette, double-click the first light source. Its attributes will display in the Modify Light Source panel. Turn off its modeling light so that the local light source will appear more clearly.
- Step 2** Set *g2* as the current parent.
- Step 3** Create a new local light source in the palette. Be sure to select an obvious diffuse color.
- Step 4** Create a new Light Source node as illustrated. The node index will automatically be set to your new light source.
- Step 5** While the new light source cube is highlighted, use **Attributes/Place Light Source** or the **Translate** tool to place it on the table lamp. Note the effect on the faces facing the light source.

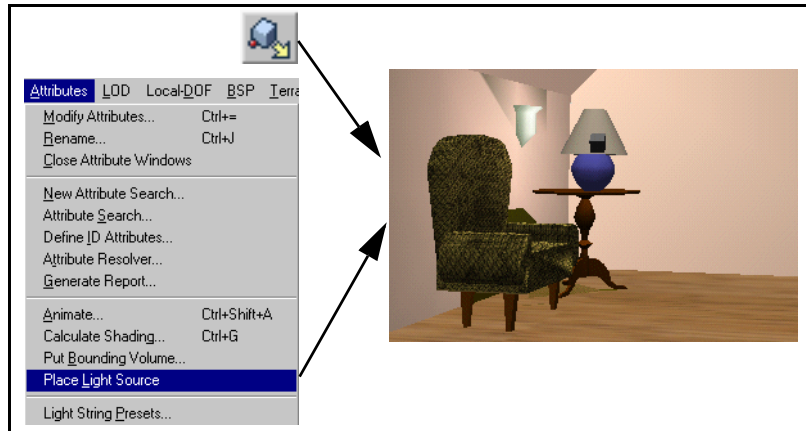

- Step 6** Save your work.

## Creating a Spotlight Source

Spotlights radiate light in a specific direction, affecting only the vertices of objects falling within the spotlight's cone of light. You define spotlight sources in the Light Source palette by selecting the Spot option button and modifying the Cutoff angles.

**Creating a Spot Light Source**

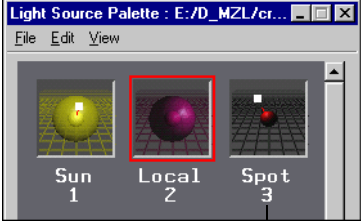

The orb displays your cutoff angles and a direction vector

The Spot Cutoff Angle defines the angle of the cone of light from the center to the edge of the beam

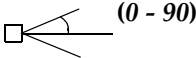

(0 - 90)

The Spot Dropoff more narrowly focuses the cone of light within the cutoff angle

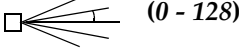

(0 - 128)

**Modify Light Source : E:/D\_MZL/creator2...**

Index: 3  
Light Name: Spot  
 Light Activated for Modeling

Light Source Type  
 Infinite  Local  Spot

Color and Direction

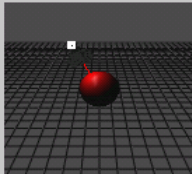

Ambient: [Black] Diffuse: [Red] Specular: [White]

Azimuth: 128 Elevation: -119

Spot Cone  
Cutoff Angle: 39.49  
Dropoff: 11.80

Spot Attenuation  
Constant: 1.00 Linear: 0.00 Quadratic: 0.00

Set ambient, diffuse, and specular color effects

## Spotlight Characteristics

The Cutoff Angle and Dropoff controls limit the size of the spot lighting effect. Remember that spotlights only affect vertices falling within the Spot Cutoff angle. It is easy to miss the target, realizing no visual effect at all.

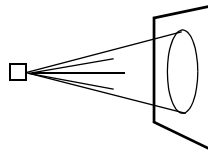

*The wall is missed!  
Vertices are outside of the spot beam with no effect on the wall*

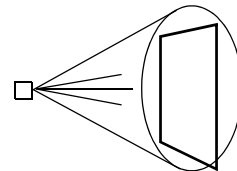

*The wall is hit!  
Vertices are included and the wall is shaded*



## Adding Spotlights to a Database

Spotlight sources are represented in the database hierarchy by a Light Source node, shown in the illustration below, and graphically with a light source cube and vector. You can position the light cube and vector and orient it anywhere in world space using *Attributes/Position Light Source* or choosing Rotate About Point.

Use Create Light Source to create Light Source nodes.

*Creating a Spot Light Source*

**Create Tools**  
Create Light Source

g1  
g2  
ls17  
Chain

Light source node  
Double-click

**LightSource Attributes : Spot**  
ID: Spot  
Modify All Reflect Selection

Light Source DB Navigator Comments

Light Source Attributes  
 Enable Index: 8  
 Global (Lights All)  
 Export To Realtime

Position  
x: 0.000000 y: 0.000000 z: 0.000000

Orientation  
Azimuth: 128.33 Elevation: 119.00

Set to the light palette index of a spotlight

Direction vector

Point the vector at a vertex

**Attributes Related  
to Spotlights**

These Light Source Node attributes affect spotlights:

*Palette Index*

The Palette Index contains the index of a spotlight source that is defined in the Light palette.

*Enabled*

Enables (activates) or Disables (turns off) the spot light source.

*Global (Lights All)*

The light source radiates on all objects with vertices within the spot beam. When Global (Lights All) is cleared, only the objects that are children of the Light Source node with vertices in the light beam will be illuminated.



## Placing and Orienting Light Sources

Local and spotlight sources can be selected and placed anywhere using Light Source mode and *Attributes/Place Light Source*.

**Selecting Light Sources**  
Choose Light Source mode and drag or click a light source in the Graphic view. You can also select its node in the Hierarchy view



**Place Light Sources**  
With the Position option button selected, drag the light source to a point in space  
With Direction selected, use the left mouse to orient a spot light beam

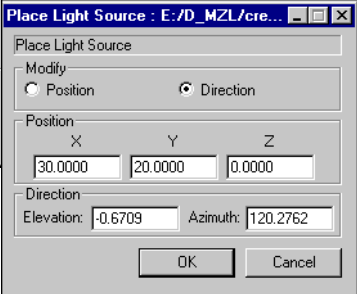

or  
Hand enter any known values

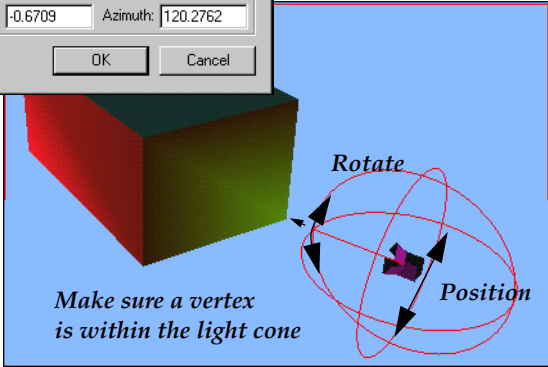

Make sure a vertex is within the light cone

## Create and Position a Spot Light Source

- Step 1** Using the file *parlor.flr*, make sure the first light source modeling light is off. This will enhance the effect of your spotlight.
- Step 2** Set *g2* as the current parent.
- Step 3** Create a new spotlight source in the palette. Select a bold diffuse color. Assign a cutoff angle of 60 degrees and a dropoff of 8.
- Step 4** Create a new Light Source node. The node index will automatically be set to your new light source.
- Step 5** While the new light source cube is highlighted, use Place Light Source to locate the spot on one of the sconces on the wall. Be sure to orient the vector up and toward the wall.
- Step 6** Note the effect on the faces that face the light source. Note particularly how the spot has no effect on vertices outside the light beam.
- Step 7** Save your work and close *parlor.flr*.



## Interesting Options

Lighting effects are often more striking when they are combined with other effects. The two options below might be interesting to you.

## Nightlife Models

Models are often difficult to see with the normal blue background, so a day/dusk/night background is provided to increase the contrast between background and model. Try it with your farmhouse model (*farmhouse.ftl*).

### View Sky Color controls

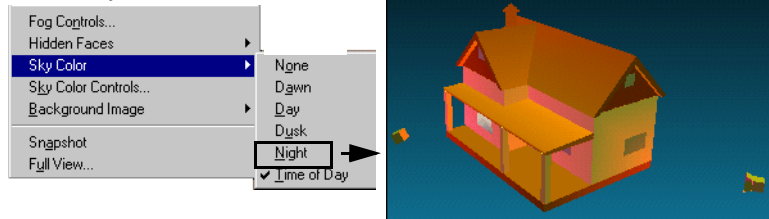

## Fog and Fog Controls

Fogging effects are not passed on to the realtime system with the flight database, but they can be used to create great texture effects, or to proof the look of a model in foggy conditions.

Fog controls are found in the View menu. Try it!

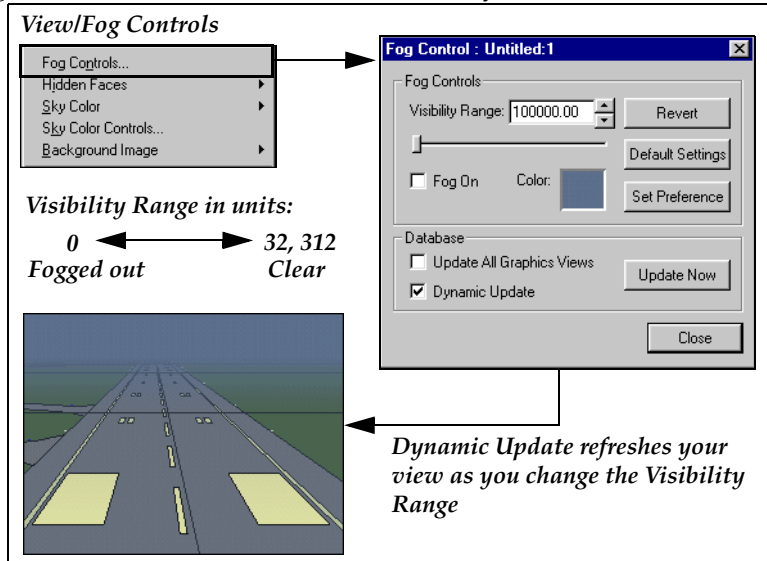



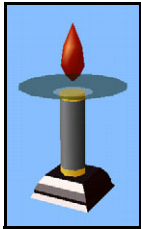

## *Materials*

### Introduction

Color and lighting have added a great deal of interest and mood to our model, yet something still does not feel right about it. It lacks the lustre of real-world objects.

Real world objects also have material qualities. That is, they are shiny, dull, transparent, or luminescent. These qualities add character and give life to an imaginary world, allowing the viewer to more comfortably accept the illusion of reality.

In this section we will create a greenhouse, applying material characteristics to make it more realistic.

### Contents

<b>SETTING MATERIAL PROPERTIES</b>	108	<b>CONSTRUCTING THE GREENHOUSE</b>	112
Material Characteristics	109	Getting Ready	112
		Add a Front Door	113
<b>APPLYING MATERIALS</b>	110	Add a Material	113
		Make it Transparent	114
<b>TUTORIAL—THE GLASS GREENHOUSE</b>	111	Move the Greenhouse	115
		Important Notes	116
<b>MODELING GOAL</b>	111		
<b>MODELING OBJECTIVES</b>	111		

## Setting Material Properties

Each material can be modified with a wide range of values. Double-clicking a material in the Material Palette displays the *Modify Material* window for that material. You can then double-click the Ambient, Diffuse, Specular, or Emissive spheres to display the *Color* window for that property.

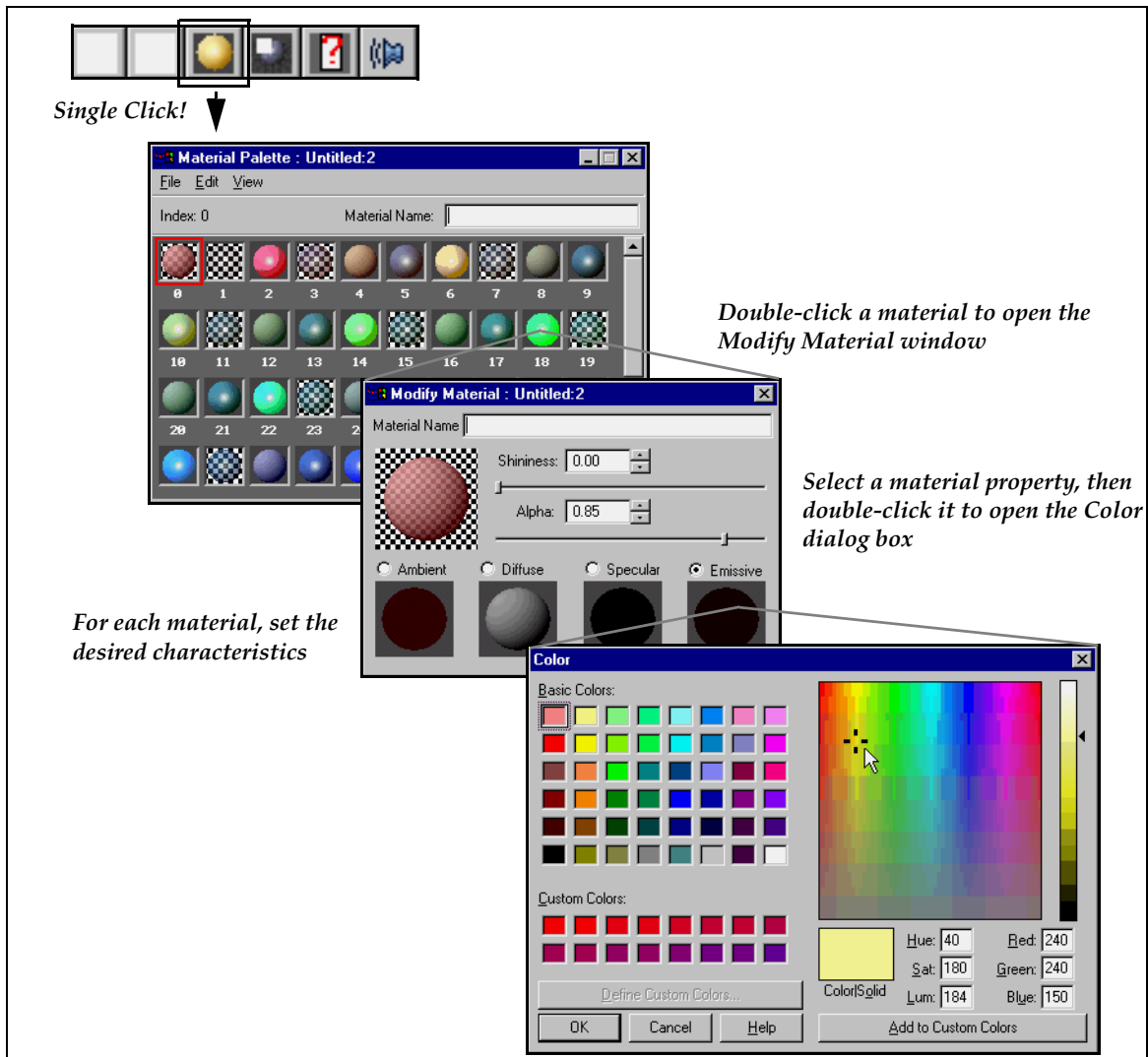

**Material Characteristics**

Each of the 64 materials in the Material palette can be configured with unique characteristics through its *Modify Material* window. To open this window, double-click a material sphere. Material characteristics and qualities include the following:

- Shininess** The quality of specularity or polish. This affects a sense of reflectance by providing a gamma curve for the specular quality.
- Alpha** The quality of transparency. A checkerboard pattern in the background helps you see its effect.
- Ambient** Surrounding, or atmospheric, color tint. Ambient color is uniformly applied as a tint to an object's overall shading.
- Diffuse** The color tint of the general material itself. Diffuse color is uniformly applied as a tint to an object's overall shading.
- Specular** The color of the material's specular highlight. The intensity and scope of the specular highlight is determined by the Shininess parameter. White is commonly used for the color.
- Emissive** Emissive light is a non-reflected highlight emitted by the object, such as a luminescent watch. Objects with emissive lighting are **not** light sources, and do not have any effect on other objects in the model. Emissive light is applied uniformly to the object.

**Modify Material Controls**

Assign a meaningful name to the index →

The sphere shows material characteristics →

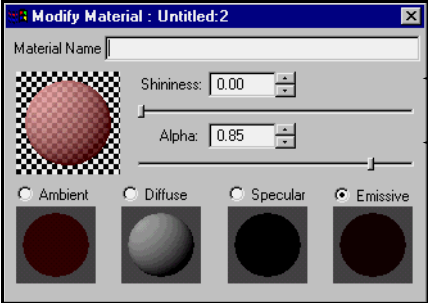

← Adjusts the specular drop off of the object's reflective surface

← Adjusts the level of transparency for the material (0 = invisible)

**Note!**  
Material Color qualities supersede the object's assigned color.  
The Flight Preference Modulate Current Color with Material in Material Palette blends the object color into the material palette spheres.

## *Applying Materials*

Material qualities add a sense of realism to a model. For example, a greenhouse would look OK if properly lighted and shaded, but it could look even better if a transparent material were applied to it.

In Creator, materials are accessed and applied using the Materials palette and the Insert Material tool in the Properties toolbox. Materials are displayed when Lighting is toggled on.

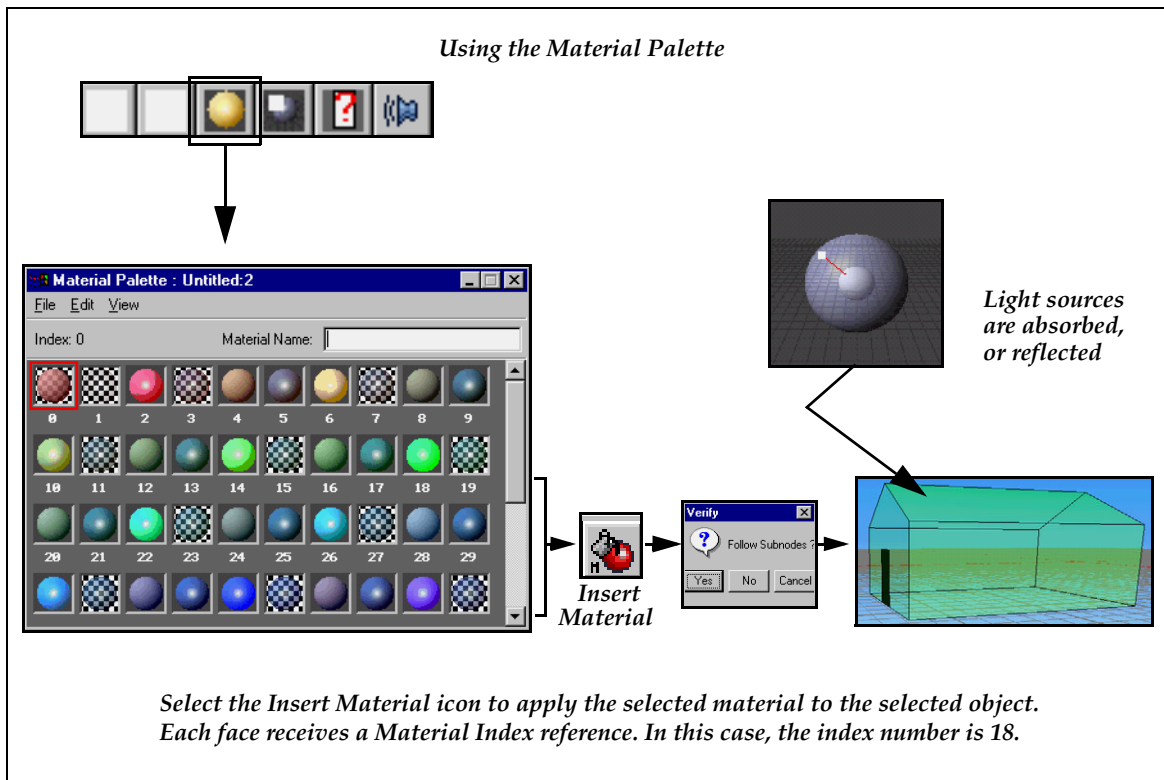

## *Tutorial — The Glass Greenhouse*

### **Modeling Goal**

In this exercise, you will construct a greenhouse and then apply the assigned material qualities to each component in the greenhouse. This demonstrates the various effects that materials can lend to a model.

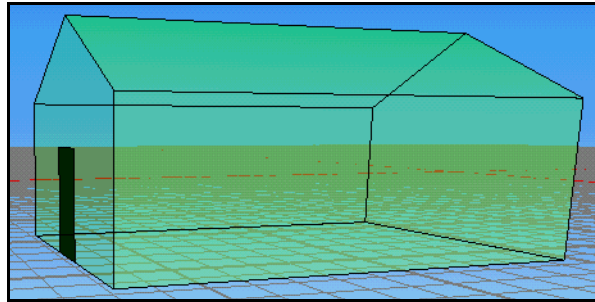



### **Modeling Objectives**

This model demonstrates the use of various tools and some effects material options can lend to the appearance of a model:

- **Polygon tool, to create a basic wall shape**
- **Wall tool, to add depth to the shape**
- **Application of material characteristics, including transparency**
- **Tracking plane control and positioning**
- **An infinite modeling light, to see the effects of shininess**

## Constructing the Greenhouse

### Getting Ready

- Step 1** Save and close any OpenFlight file you have open. Choose *File/New* and create a new file called `greenhouse.flt`.
- Step 2** Choose *Info/Preferences* (Ctrl+Shift+P), and click the Flight tab. Set the Default units to Feet, and click OK.
- Step 3** In the View panel, set grid Dimension to 1, and the grid to the X-Z plane.
- Step 4** Make the g2 node the Parent.
- Step 5** Use the Polygon tool to outline the shape of the greenhouse. Make it 20 feet wide and 15 feet tall at the peak (the wall height is 10 feet). See the illustration.
- Step 6** Rename the p1 node to "Front" (Ctrl+J). 
- Step 7** Select the Front polygon and use the Wall tool (Shift+W) to make the depth 30 feet. Leave Keep Bottom selected. 

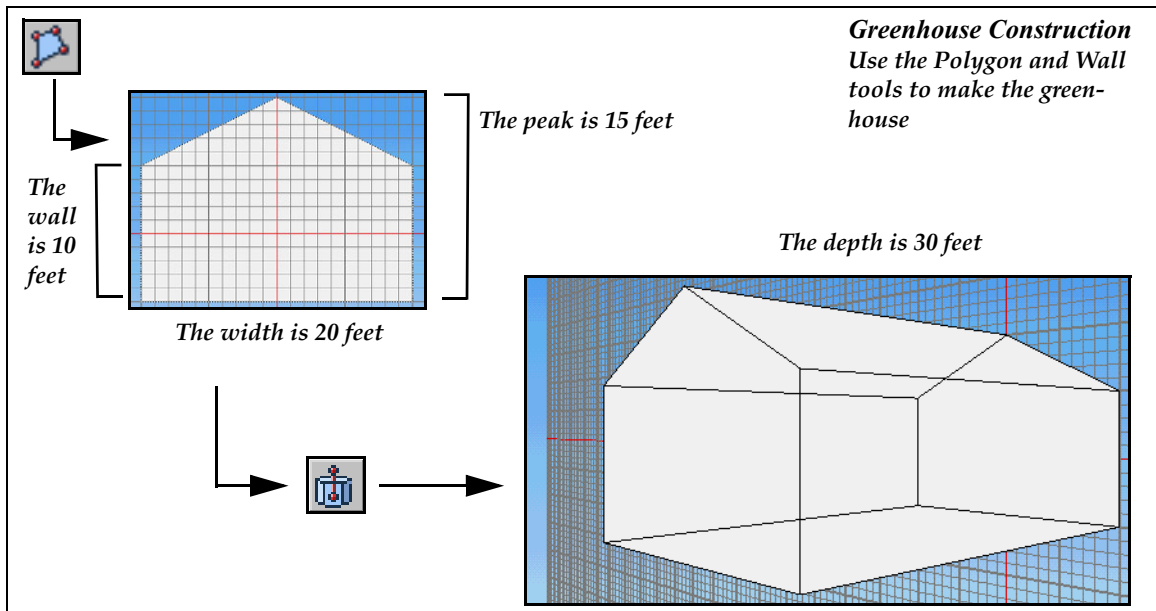

## Add a Front Door

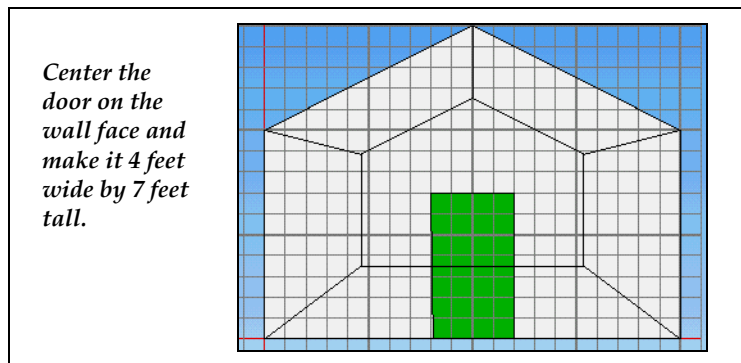

We are ready to add a door to the front of the greenhouse.

- Step 1** In the View panel, select **FAC** to snap the tracking plane to the front wall of the greenhouse.
- Step 2** Make the **Front** polygon the **Parent**. The door will be a subface of the **Front** wall.
- Step 3** Make the **Primary Color** green so the door will be more visible.
- Step 4** Use the **Polygon** tool to outline the door. Make the door 4 feet wide and 7 feet tall.



## Add a Material

We'll choose a material, then apply it to the greenhouse.

- Step 1** Select the **Current Material** icon on the **Toolbar**. 
- Step 2** Choose a light green material, such as material number 18. Name the material *Greenhouse* (type in the **Name** field).
- Step 3** Select the entire greenhouse (choose the **g2** node in the **Hierarchy** view).
- Step 4** Select **Insert Materials** from the **Properties** toolbox. In the **Verify** dialog box, choose *No* (do not follow subnodes). 
- Step 5** If the material is not immediately visible, choose *Attributes/Calculate Shading* (**Ctrl+G**). Select *Lit* and click **OK**.

The material is now visible, but the greenhouse doesn't look right. Let's make the material semi-transparent to simulate the visibility of a glass surface in a real greenhouse.

**Make it Transparent**

**Step 1** Open the Material palette. Double-click the Greenhouse material to display the *Modify Material* window.

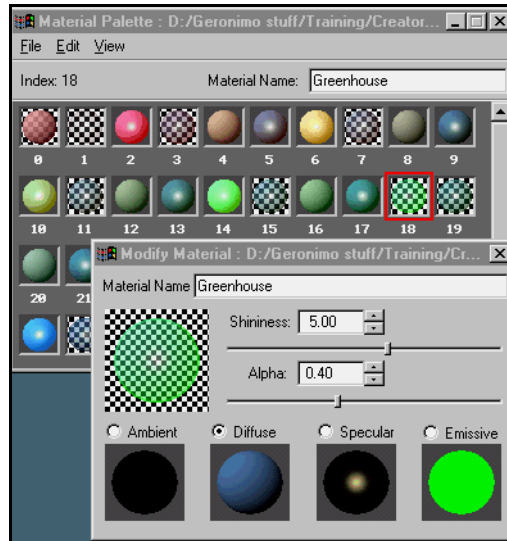

**Step 2** Change the Alpha value to .4 to make the material more transparent (zero is completely translucent, one is completely opaque).

**Step 3** Change the shininess value to 5. This will affect the specular quality. As you change it, you can see its effect on the Specular sphere in the *Modify Material* window.

**Step 4** Close both windows and notice the updated effects on the greenhouse.

*Throw no stones!*

*The greenhouse is now transparent.*

*Make sure the door is not transparent.*

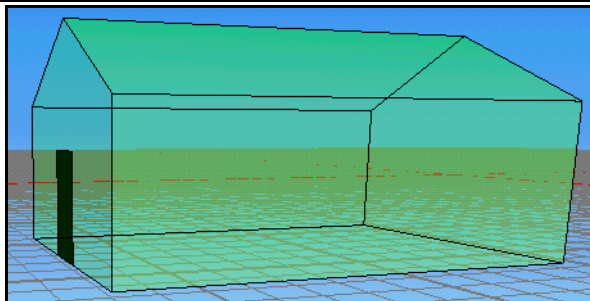

*Rotate the eyepoint around the greenhouse with the right mouse button to see the specular effects. Try changing the shininess value to see the effect on the greenhouse.*



## Move the Greenhouse

Your greenhouse is complete. Now we'll move it to the `farmhouse.flt` file.

- Step 1** Select the entire greenhouse and choose *Edit/Copy* (Ctrl+C). The greenhouse is now copied into the Graphics buffer. To view the Graphics buffer, choose *Edit/View Graphics Buffer*.

*Your greenhouse is visible in the Graphics buffer. Use the Graphics buffer to make sure you have copied the entire object.*

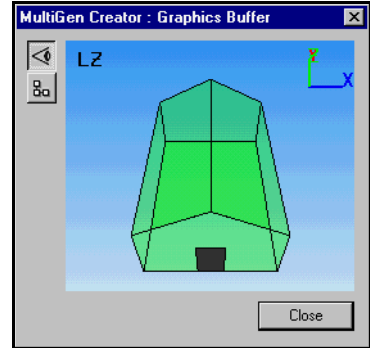

- Step 2** Open the `farmhouse.flt` file. Make sure `db` is set as Parent.
- Step 3** Choose *Edit/Paste* (Ctrl+V) to paste the greenhouse into the `farmhouse` file.
- Step 4** Set the To Point to place the greenhouse behind the farmhouse.

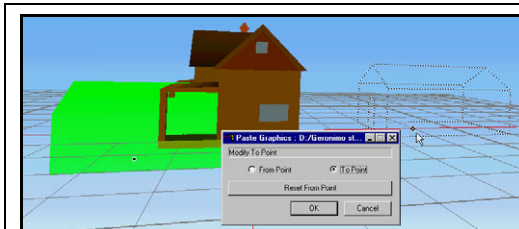

*Position the greenhouse behind the farmhouse using the To Point in the Paste Graphics dialog box.*

***Congratulations!***  
*You just increased the resell value of your farmhouse. But, of course, the taxes are higher now.*

*Remember to save your file!*

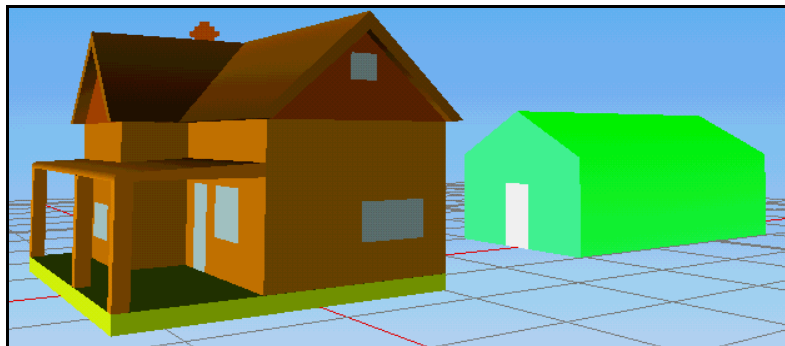

## Important Notes

*Note 1:* Lighting and material effects require the face normals created by Calculate Shading.

*Note 2:* Material qualities (including color) take precedence over face colors. If material colors need to match face colors, change the material color.

*Note 3:* Pay careful attention to database structure when using material transparency. Faces that should appear behind a transparent face need to be drawn before the transparent face in the database hierarchy.

*Note 4:* If you combine material transparency with face transparency, Creator multiplies the two values together to arrive at the final transparency value. For example, if the alpha value of the material applied to the face is 0.5 and the face transparency is 0.5, the net transparency is .25 (more transparent).

As a side note: To see the a face color combined with any material, assign the primary color to the face color, and set the Flight preference *Modulate Current Color with Material*. All materials will reflect the current color. *This is a visual effect only and does not affect either the materials or actual face coloring.*



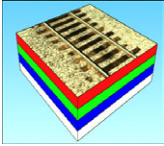

## *Applying Textures to Your Farmhouse*

### *Introduction*

Texturing is a technique to map an image onto a geometrical shape to provide special effects or a level of realism that is not geometrically practical. A single texture mapped to a single polygon or volume is a highly economical alternative to the potentially hundreds of polygons otherwise needed to render a realistic model image.

In this session, you will explore the texturing tools offered by Creator to import and map texture data to your model.

### *Contents*

<b>TEXTURING</b>	118	<b><i>APPLYING TEXTURES TO THE HOUSE</i></b>	125
What is a Texture?	118	Texture Tools	125
Preparing to Explore Texture Mapping	118	What Do They Do?	125
Texture Mapping	119	Your First Window	126
		Apply the Texture	127
<b><i>THE TEXTURE PALETTE</i></b>	120	Roof, Doors, and Other Windows	128
Loading the Palette with Textures	121	Applying a Texture to Many Faces	129
Adding Textures to the Palette	122	A Little Landscaping	130
Predicting Texture Memory Demands	123	The Chimney	131
Important Tip!	123	Admire your Work!	132
Palette Statistics	124	Some Notes	132

## Texturing

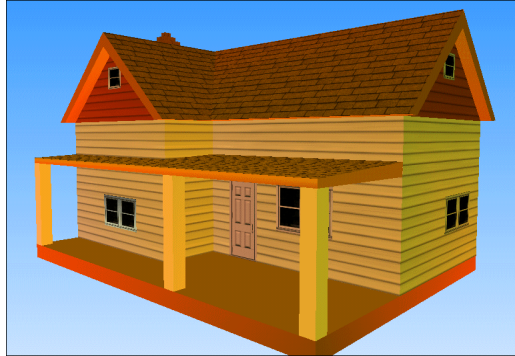

### What is a Texture?

Textures are simply 2D images digitized into rectangular arrays of color data elements and mapped over 3D shapes projected onto the screen.

Each data element of a texture is called a *texel*. The size of the texel is determined by the digitized resolution of the image and its scaled projection to the screen. Texels can be larger or smaller than screen pixels, leading to the need for special processing (*filters*) to maintain image quality.

In 3D, texture images are defined as a  $u, v$  coordinate plane mapped to the  $x, y, z$  coordinates of a geometric model. As the 3D model is transformed and projected to the screen, the mapped texture is also rotated, scaled, and drawn on the screen, while appearing to lay on the surface of the model.

### Preparing to Explore Texture Mapping

**Step 1** Open the file *FarmhouseLit.ftt*. For Windows, this file is in the `\Program Files\Multigen-Paradigm\resources\tutorials\creator\DesktopTutor\Models` directory.; for IRIX, it is in `/usr/local/MultiGen-Paradigm/resources/tutorials/creator/DesktopTutor/Models`. This file contains a Texture palette pre-loaded with the farmhouse textures.

**Step 2** Activate Display Texture by typing "T" on the keyboard. A T will appear in the upper left corner of the Graphic view.



## Texture Mapping

The generalized term *Texture Mapping* refers to the processes of:

- Selecting or identifying the current texture
- Mapping texture  $u,v$  coordinates to geometric coordinates
- Modulating image color data with face and shading colors
- Applying filtering to eliminate aberrations caused by pixel to texel relationships

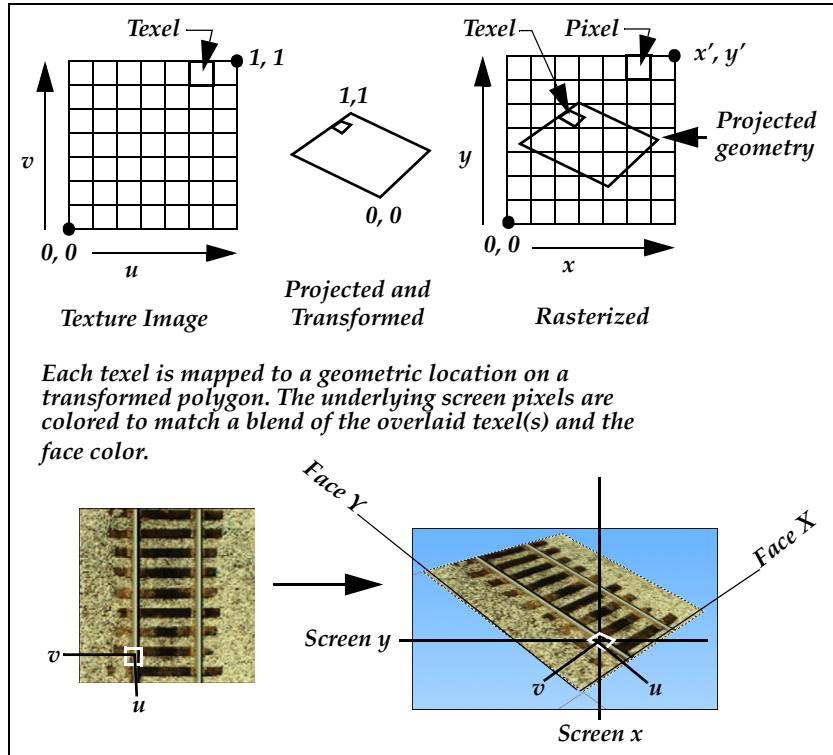



## The Texture Palette

The Texture palette is accessible through the shortcut by clicking the **Current Texture** button or choosing *Palettes/Texture*.

- Using the illustration below, select the Texture palette:

**Accessing the Texture Palette**

The **Current Texture** button displays the current texture, or a "no texture" icon: 

or a "not found" icon: 

Select a texture by clicking the image once

**Bank 0, with mini-images in yellow**

95 banks, each with up to 256 textures; 24,325 total indexes!

There are no limits to pattern size, but patterns larger than 1024x1024 are costly in performance

**File, Edit, and Info menus**

Hold left mouse to drag-arrange pattern positions

One click to select a pattern

Selected pattern is highlighted in red

Selected pattern file name and current index

slider to access 95 banks; click the bank to view it (highlighted in red)

The screenshot shows a window titled "Palette 1" with a menu bar (File, Edit, View, Info). The main area displays a preview of a selected texture (a wooden fence) over a house facade. Below the preview is a row of bank indicators (0-6), with bank 1 highlighted in red. A slider at the bottom allows navigating between banks. Annotations with arrows point to various UI elements and provide detailed instructions on how to use the palette.

**Tip!** Image files are read into memory from the palette from left to right, bottom to top. Load your most used textures in the lower left corner of the first bank to trim access time.



## Loading the Palette with Textures

When working on a project, it is common practice to load up the palette with textures and then save the palette for later use.

In this case, a palette of textures for the farmhouse has been saved and can be loaded into the palette for the next phase of our project.

- **Palette files contain references to textures used in models or entire worlds. Palette files are loaded with the Texture palette *File/Load Palette* option, and have the suffix *\*.txt*.**

*Loading a palette*

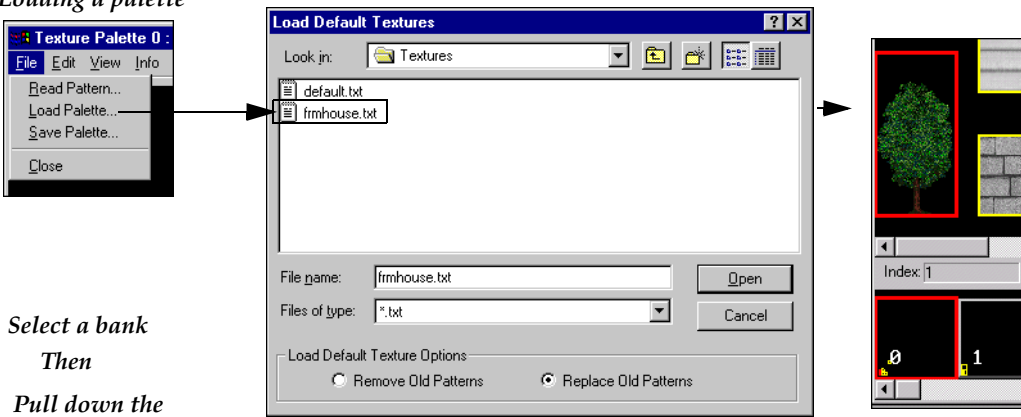

Select a bank  
Then  
Pull down the  
File/Load Palette  
menu item

Palette images  
are loaded and  
displayed

Select the directory `\Multigen-Paradigm\resources\tutorials\DesktopTutor\Textures` (Windows)  
or `/usr/local/MultiGen-Paradigm/resources/tutorials/DesktopTutor/Textures` (IRIX)  
Select the palette file `frmhous.txt`  
Double click the file to load or click 'Open'

## Try it!

### Step 1

Using the illustration above, load the texture palette file `frmhous.txt` from the `\Program Files\Multigen-Paradigm\resources\tutorials\creator\DesktopTutor\Textures` directory. (Windows) or `/usr/local/MultiGen-Paradigm/resources/tutorials/creator/DesktopTutor/Textures` (IRIX) directory. An entire set of textures is loaded into the Texture palette.

### **Adding Textures to the Palette**

Individual image files from any source can be loaded into the palette, and the palette itself can be resaved and kept with project directories.

- Individual texture files are individually loaded using the **File/Read Pattern** option

*Adding a file to the Palette*

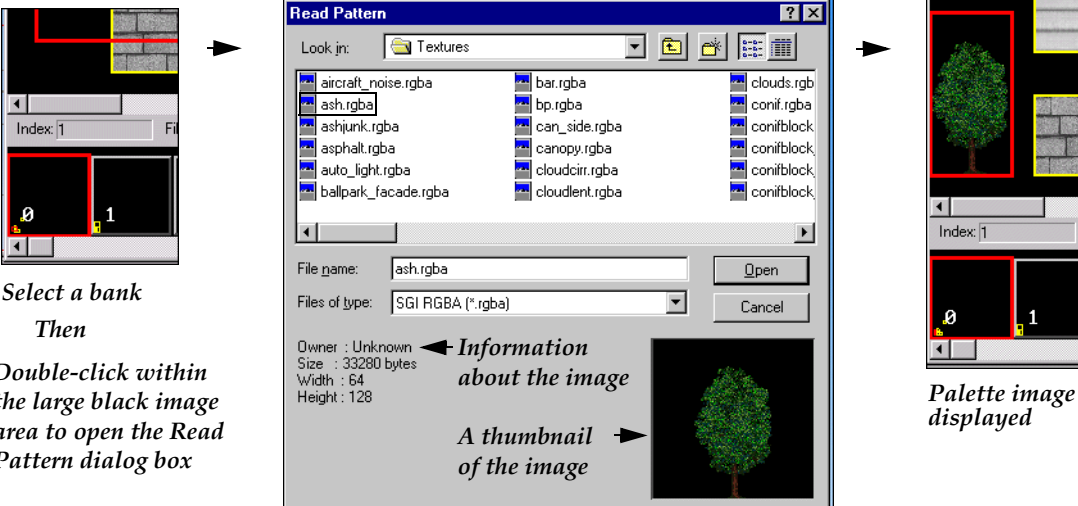

*Select a bank*  
*Then*  
*Double-click within the large black image area to open the Read Pattern dialog box*

*Select the directory*  
*Select the file type or All Files*  
*Double click the file to load*

*Information about the image*  
*A thumbnail of the image*

*Image of Texture (may be partial)*

*Palette image displayed*

### **Try it!**

**Step 1** Using the illustration above, load the `ash.rgb` file `\Program Files\Multigen-Paradigm\resources\tutorials\creator\DesktopTutor\Textures (Windows)` or `/usr/local/MultiGen-Paradigm/resources/tutorials/creator/DesktopTutor/Textures (IRIX)` directory. The `ash.rgb` file is a single file added to the palette.



## Predicting Texture Memory Demands

An essential task related to texturing is keeping track of how much memory textures consume. Creator can support textures greater than 4,096 by 4,096 (a 50MB RGB file), but most image generators have memory restrictions that limit the number and size of your textures.

*It is very important to consider the texture limits of your target system before building your model's texture library!*

**Gray scale textures** (*Intensity Patterns*) typically have one color component, with each texel a shade of gray. The advantage of intensity patterns is they take up very little memory and can be blended with face colors to produce a variety of effects.

**Color textures** (*RGB or RGBA Textures*) usually consist of three or four components, typically *Red, Green, Blue*, or *Red, Green, Blue, and Alpha*. *Alpha* is commonly used for fogging and transparency.

A good basic formula for calculating texture memory requirements is:

*Memory size = X texels \* Y texels \* #components*

### Example:

A 1024 x 1024 intensity texture requires 1024 x 1024 x 1 bytes = 1Mb of texture memory. The same texture in RGB + Alpha requires 1024 x 1024 x 4 bytes = 4 Mb!

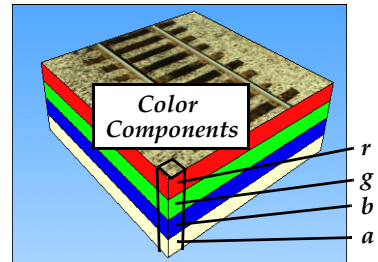

*Each component = 1 byte per texel*

### **Important Tip!**

Never try to save texture space by using odd dimensions. Texture dimensions should always be sized to a power of two to make more efficient use of texture memory and to prevent unwanted side effects from some image generators.

In Creator, the amount of memory required for all of the textures in your model or world is calculated and made available through the *Info/Statistics* window in the Texture palette.

### Palette Statistics

Creator keeps track of the texture load your model represents and makes this information available through the Texture palette *Info/Statistics* menu item. Creator also adds this information to the more general *Info/Statistics* (**Ctrl+?**) menu item.

*Texture Palette Statistics*

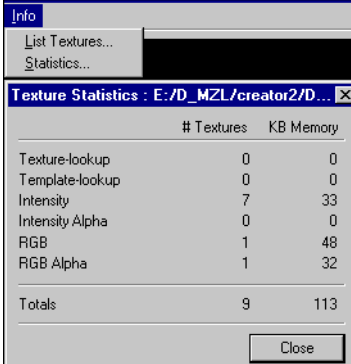

	# Textures	KB Memory
Texture-lookup	0	0
Template-lookup	0	0
Intensity	7	33
Intensity Alpha	0	0
RGB	1	48
RGB Alpha	1	32
Totals	9	113

**Tip!** By taking more advantage of intensity (grayscale) images, the texture memory load imposed by the farmhouse is slight.

**Step 1** After examining the Statistics panel, close the Texture palette. You are ready to texture the house!



## *Applying Textures to the House*

With a texture selected in the Texture palette, your next option is to close the palette and apply, or map, the selected texture onto the house using one of a variety of texture tools.

### **Texture Tools**

Creator provides tools to map textures around various geometric shapes. If mistakes are made, the texture can be reapplied or later adjusted using the Modify Texture tools.

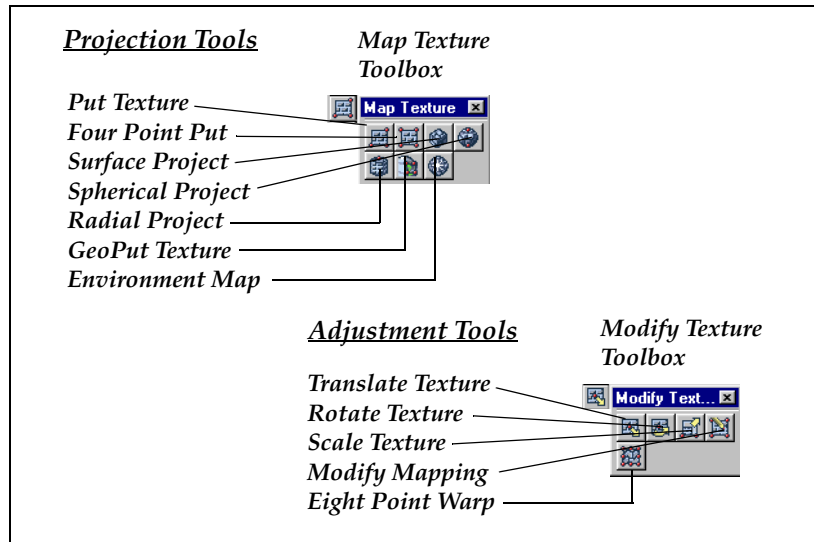

### *What Do They Do?*

<i>Put Texture</i>	Applies a texture onto one or more planar faces using three points.
<i>Four Point Put</i>	Applies a texture onto one or more planar faces using four points.
<i>Surface Project</i>	Wraps a texture around a 3D cubic volume.
<i>Spherical Project</i>	Wraps a texture around a spheroid.
<i>Radial Project</i>	Wraps a texture around a cylinder or cone.

## Your First Window

The first task is to apply a window texture to the windows of the house. You can use one texture to create both single and multiple pane windows using the Put Texture tool.

**Step 1** Set the modeling mode to Face mode (Shift+F) and select one of the large front windows.

**Step 2** Enter Ctrl+I or choose Isolate from the Select menu to isolate the face in its own window. Isolated views place the selected geometry in another window for local editing. When you are done editing, close the isolated window to return to the main view.

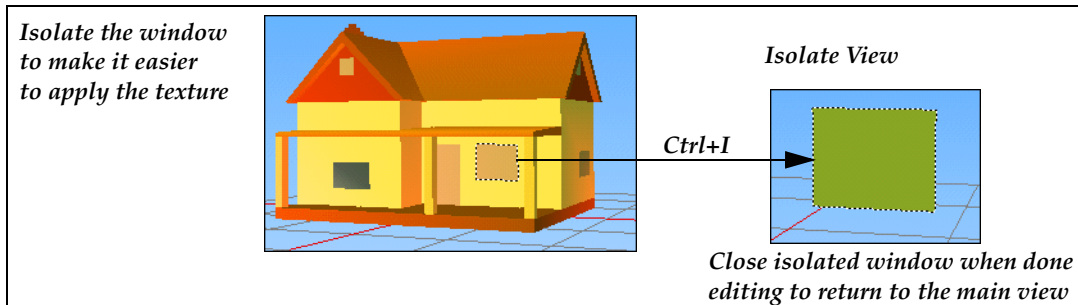

**Step 3** Open the Texture palette, select the second bank (bank 1), and select the window image. Then close the palette.

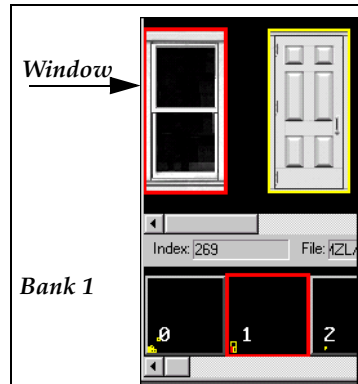

**Step 4** Select the window face in the isolated view (if not already selected) and enter v to zoom and center it in the screen.



## Apply the Texture

The Put Texture tool is used to apply textures to planar faces.

- Step 5** Looking at the illustration, map the window texture to the window face. Be very careful to hold the middle mouse down and drag the Alignment point along the lower edge to correctly position the texture.

*Put Texture aligns textures with Origin, Alignment, and Shear points. These points can be snapped to vertices (middle mouse), or dragged along edges (hold middle mouse), or applied to the tracking plane (left mouse) anywhere around the face(s) to be textured*

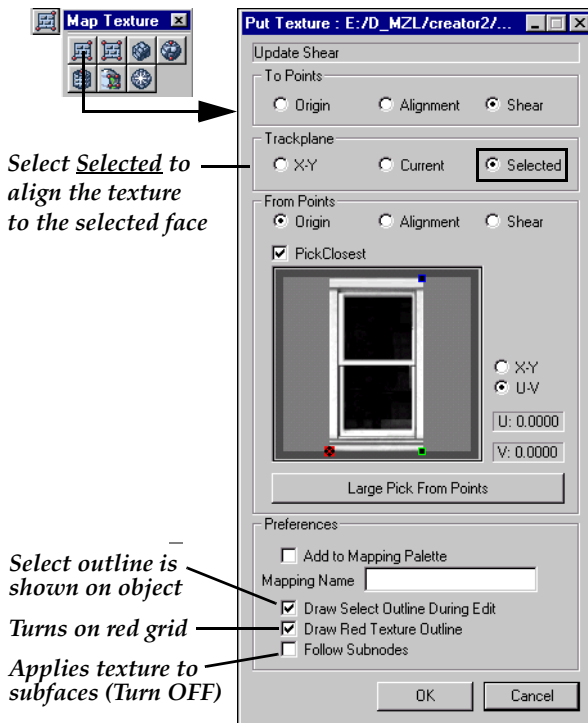

*With the middle mouse, click once(!) the lower left vertex to anchor the Origin.*

*Point to and Hold the middle mouse down to drag the Alignment point to the middle of the bottom edge.*

*With the middle mouse, click the center of the top edge where the red guideline intersects it to center the Shear point*

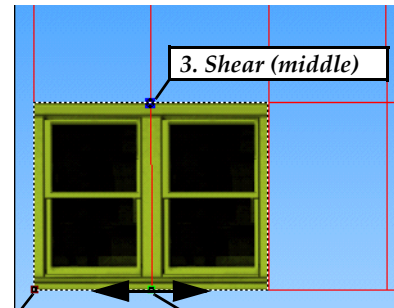

1. Origin (middle mouse)      2. Alignment (drag middle mouse)

*Red grid reveals the plane, size, and orientation of the texture. The texture is clipped against the geometry*

- Step 6** When the texture is applied, close the isolated window:

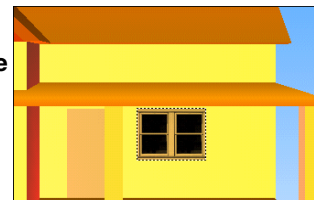

## Roof, Doors, and Other Windows

Isolating the view is most useful when working accurately with texturing the larger windows, but it is not necessary to isolate if you can easily access a smaller feature.

For the smaller windows and the doors, simply select the face, select the Put Texture tool, middle-mouse click on the bottom left, bottom right, and top right vertices of the face, and then click OK.

The challenge for the roof is to make sure the texture on each face is the same size as the other roof faces, and each texture must be oriented to the correct direction.

**Step 1** Select a roof face.

**Step 2** Use FAC to set the tracking plane on the roof face. Make sure the grid dimension is set to 1.0.

**Step 3** Select Put Texture, and in the Trackplane section, select the Current option button. This indicates that you want to apply the texture to the current tracking plane position.

**Step 4** Left mouse click the Origin and Alignment points 3 grid units apart along an edge, and then click OK. The texture will be scaled to size.

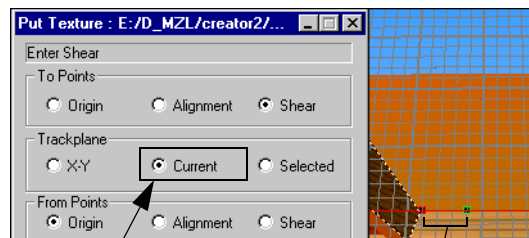

*Current option button*

*3 units apart (Left)*

**Step 5** Repeat steps 1 - 4 for each roof face, working your way around the house until all roof faces are done (Do not forget the porch roof!).

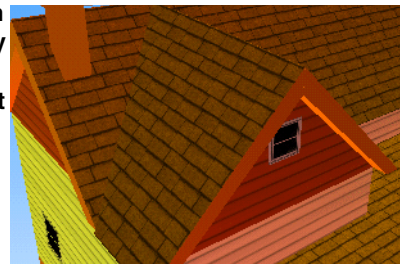

## Applying a Texture to Many Faces

The next step is to add the wall textures. You can take advantage of the shape of the model. Since the walls are just an irregular cylinder, use the Radial Project tool to texture all walls simultaneously!

- Step 1** In the Hierarchy view, select the Walls node to all the wall faces .
- Step 2** Type *v* to center and scale the house to your view.
- Step 3** Open the Texture palette and select the siding texture in Bank 0. Close the palette.
- Step 4** In the View panel, turn off Grid Snap and select XY, then XZ to reset and flip the tracking plane up through the house.
- Step 5** Freeze the X and Y coordinates using the Freeze Flags on the database toolbar. Movement will be along the Z axis only, making sure your texture remains properly aligned.
- Step 6** Using Radial Project, drag the red indicator to vertically scale the texture on the walls. See the illustration. Click OK when it looks right:

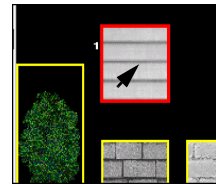

*Radial Project*

Place the cursor on the red indicator and drag it downward.  
Release the mouse button when the siding appears correct.

Be sure to turn off the freeze flags when done!! Click here →

## A Little Landscaping

You can use the multitexture feature to layer and blend multiple textures together on one face. This is useful when you don't want to add additional polygons for details.

Climbing ivy is a nice touch for a side of the farmhouse. You will layer an ivy texture with the siding texture and blend them. The ivy will appear to magically cling to the siding texture.

**Step 1** Unfreeze the X and Y coordinates on the database toolbar.



**Step 2** Select the face on a side of the farmhouse.

**Step 3** Open the View panel. Select FAC to align the trackplane to the face.

**Step 4** Decrease the grid coordinates to 1 unit or less.

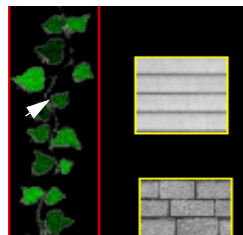

**Step 5** Notice that the siding texture is Layer 0 by default in the Texture pull-down menu in the View panel. Choose Layer 1 for the ivy texture.

**Step 6** Open the Texture palette and select the ivy texture in Bank 0. Close the palette.

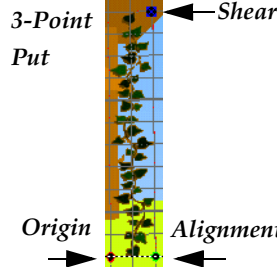

**Step 7** Use either the 3-Point Put tool or 4-Point Put tool to place the ivy texture on the wall. Select a long, narrow rectangular area on the grid that reaches upward. You can also select multiple faces, such as the wall and gable, before you use the Put tool. The same texture can be applied to multiple faces at one time.

**Step 8** Choose Blend in the Texture field in the View panel. The two textures blend together.

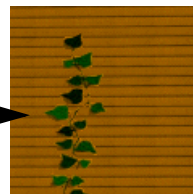

*After choosing Blend, the ivy and siding textures blend together*



## The Chimney

The next step is to add the chimney textures. Again, the Radial Project tool is used, but this time you can use its repetition factor to scale the bricks to look correct.

- Step 1** Select the Chimney hierarchy node, so all of its faces are selected.
- Step 2** Isolate the chimney (Ctrl+I) and type v to center and scale it to your view.
- Step 3** Open the Texture palette and select the brick texture in Bank 0. Close the palette.
- Step 4** In the View panel, turn off Grid Snap and select XZ to flip the tracking plane up. Select CTR and middle-click a center point on the chimney. See the illustration.
- Step 5** Freeze the X and Y coordinates. Movement will be along the Z axis only for texture alignment.
- Step 6** Choose Radial Project and drag the red indicator to vertically scale the brick pattern on the sides so the chimney steps are 1 brick deep.
- Step 7** Slide the Radial Project Repetition Factor slider to shrink the horizontal width of the bricks until they appear correct. Click OK when finished, and close the isolate window.

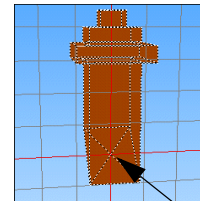

Click Here



**Radial Project**

*Repetition Factor controls how many times the texture is repeated around the volume, scaling horizontally*

*Be sure to turn off the freeze flags when done!! Click here*

## Admire your Work!

Now that you've textured the model, take a moment to admire it.



*The house with lighting and textures (This file is FarmhouseLit.flt)*

## Some Notes

### Important Face Attributes

When applying textures to faces, it is important to be aware of face attributes that can change their appearance. Double-click a face or select a face, and enter **Ctrl+=** to see the Face Attributes window.

■ **Colors tab: Base Texture Attributes** Contains the Texture palette index for the texture that is applied to the face.

■ **Drawing tab: Render Textured Polygons White** Overrides the assigned face color with white, allowing the texture colors to be seen directly without modulation.

■ **Drawing tab: Render Both Sides Visible** The polygon and its texture is visible from both sides.

### Important Preferences for Textures

There are many texture options, tools, and features not covered in this introductory tutorial. A few important preferences include the following, which are located on the State tab of the *Preferences* window.

■ **Draw TextureSet Creator** to display textures by default. This should generally be left cleared (use the T toggle).

■ **Dynamic Texture** Continuously draws textures as you rotate your views. Unless you are editing on a very fast machine, leave this cleared.

■ **Alpha Blending** Blends in Alpha fogging and transparency effects. This must be set to view Alpha effects.





## Constructing Vehicles

### Introduction

One of the most common models needed in simulations is vehicles. Cars, trucks, airplanes, and military equipment, such as tanks and aircraft carriers, all share some common characteristics. For realtime simulation, they must have a relatively low polygon count, yet retain visual realism and flexibility.

Low polygon count is attained using good modeling practices when creating the model. Textures add realism, while keeping polygon count to a minimum. Some vehicles are copies of their real-world counterpart and some vehicles are fanciful inventions that only exist in computer games. Either way, you can use background images to create 3D vehicles from 2D specifications. Scanned images of blueprints, photos, or sketches can be placed on a polygon as a background image, so your vehicle (or other models) can be created to scale.

### Contents

<b>INTRODUCTION</b>	138	Align to Background Image	147
<b>USING A POLYGON FOR A BACKGROUND IMAGE</b>	139	Lofting the Cross-Sections	148
<b>TUTORIAL—MODELING WITH THE WALL TOOL</b>	140	Fine-Tuning the Shape by Moving Vertices	149
<b>MAPPING THE BACKGROUND TEXTURE</b>	141	Tweaking the Model	150
Outline the Truck with the Polygon Tool	142	<b>MIRROR THE TRUCK</b>	151
Wall it up!	142	<b>MAKING A 3D TEMPLATE</b>	153
Add Detail with Texture	143	Tips for 3D Templates	154
Creating Tire Polygons	144	<b>BOUNDING VOLUMES</b>	155
<b>TUTORIAL — CROSS-SECTIONAL MODELING</b>	145	<b>CREATING AND CUSTOMIZING BOUNDING VOLUMES</b>	156
Creating Truck Cross-Sections	145	Make it Visible	157
		Change its Size	157
		<b>BOUNDING VOLUME OFFSETS</b>	158
		Shrink-Wrap it!	160

## *Introduction*

Background images give you a good start when you begin modeling a three-dimensional vehicle from a two-dimensional scanned image. They provide a good point of reference so you can build an object to scale. Background images do not automate the task of modeling or eliminate the need for good modeling practice.

These exercises demonstrate two methods for modeling with background images:

- **The Wall tool method**
- **The Loft tool method (cross-sectional modeling)**

The first technique uses the Polygon tool to outline part of the background image and then the Wall tool to add depth to the outlines. This is a quick and relatively easy technique.

The second technique uses the Polygon tool to make cross-sections, and then the Loft tool to connect them. This technique works well for circular objects, such as the fuselage of airplanes. Since the width of these fuselages varies from front to back, you can construct cross-sections, which are made up of circular or irregular sided polygons, then use the Loft tool to connect the cross-sections together to form the fuselage.

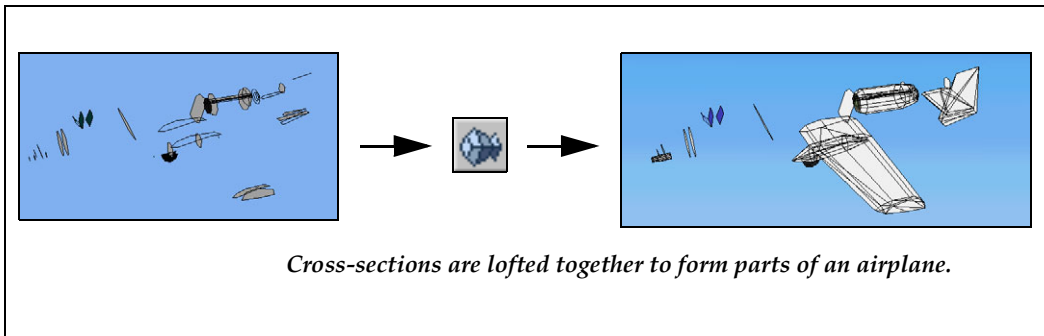

Once the model is complete, the cross-sections are deleted, since they no longer add detail and needlessly increase the polygon count. Note that each vertex in a cross-section becomes a face on the model, so fewer vertices result in a lower polygon count.

Both the Wall and the Loft method has its advantages, and you can use both techniques to create a single model.



## Using a Polygon for a Background Image

The Background Image function is described in the MultiGen *Creator User's Guide*. Another technique which is used in this chapter is to map an image to a polygon and then use the polygon as a background image.

This technique is similar to the Background Image feature but allows you to:

- Change the polygon size to easily scale the scanned image to match the tracking plane
- Use several polygons to represent the height, width, and depth of an object
- Move the eyepoint without changing the scale of the background image

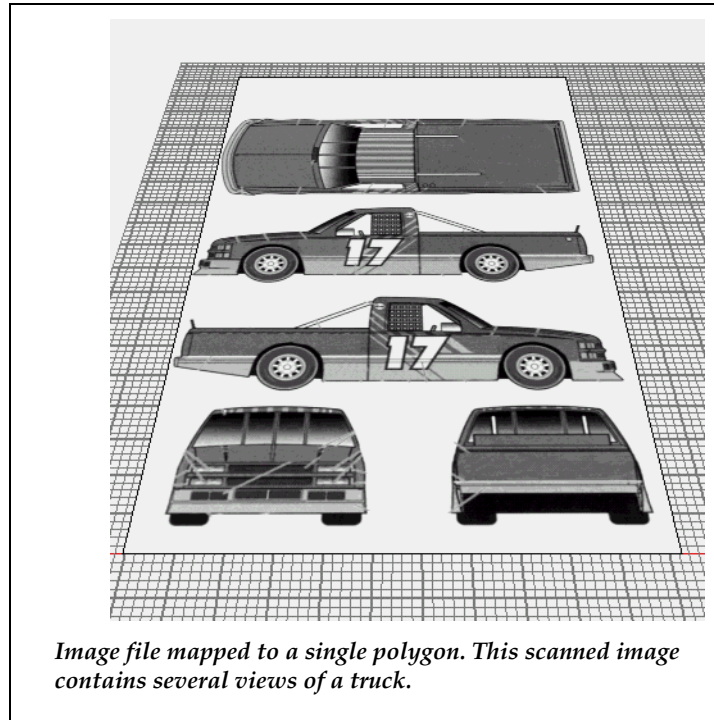

## *Tutorial — Modeling with the Wall Tool*

### **Modeling Goal**

In this exercise, you use a scanned image to create a truck with the Polygon and Wall tools.

### **Modeling Objectives**

This model illustrates polygonal outlining and the use of the Wall tool.

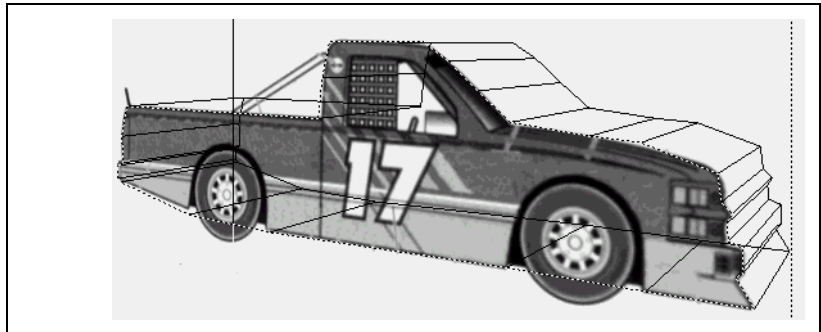

### **Creating a Background Polygon**

- Step 1** Open a new file in MultiGen, and set the grid to 5.0.
- Step 2** Create a polygon approximately 9 units wide by 14 units long.
- Step 3** Click Current Texture in the Toolbar. In the Texture Palette, choose *File/Read Pattern*.
- Step 4** In the *Read New Pattern* dialog box, click OK.
- Step 5** Open the image, *diehard2.jpg* in the `\Program Files\Multigen-Paradigm\resources\tutorials\creator\DesktopTutor\Textures (Windows)` or `/usr/local/MultiGen-Paradigm/resources/creator/DesktopTutor/Textures (IRIX)` directory. This is a scanned image of the front, back, top and side views of a truck. Close the Texture palette by choosing *File/Close* in the *Texture Palette* window.
- Step 6** Turn on textures (press the T key).



## Mapping the Background Texture

**Step 1** In the Graphics view, select the Put Texture tool from the Map Texture toolbox to display the *Put Texture* dialog box.



**Step 2** In the Graphics view, place the Origin point on the lower left-hand corner of the polygon.

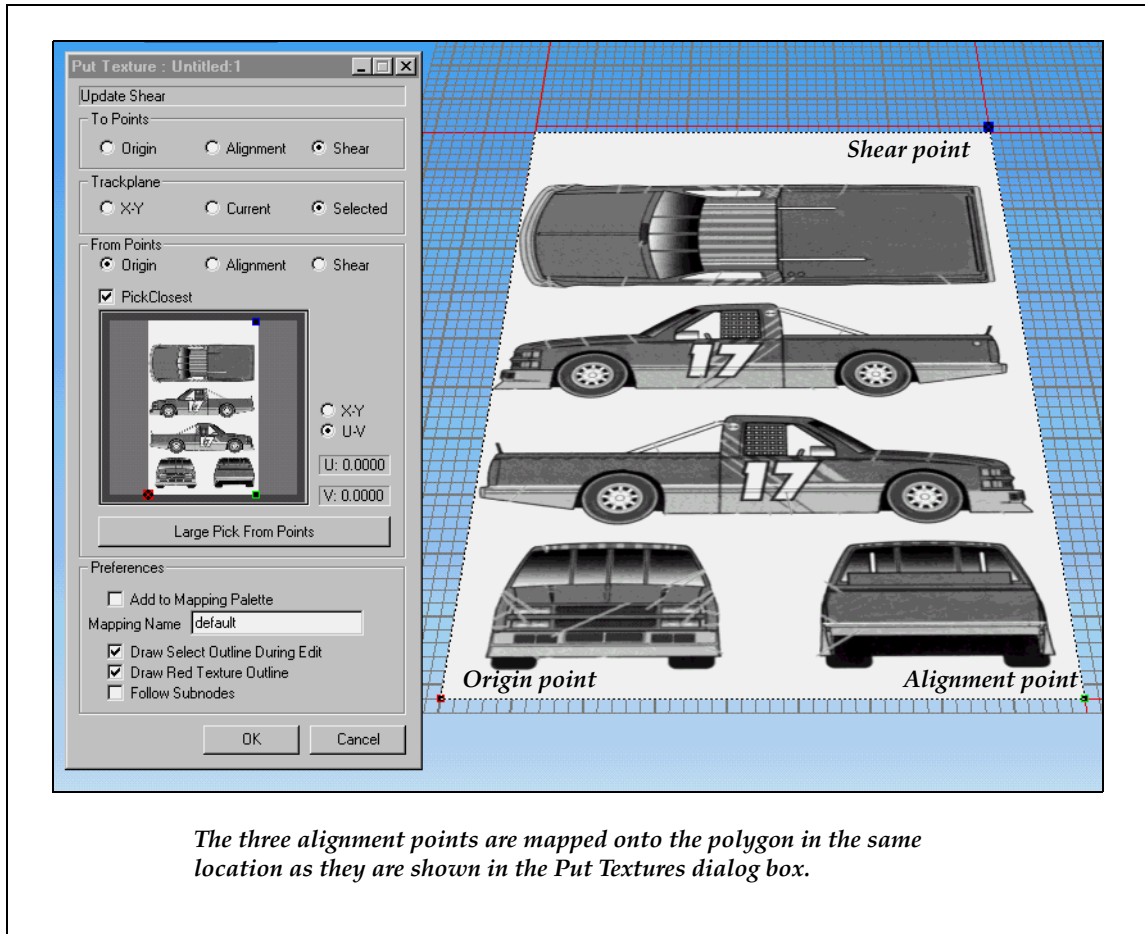

**Step 3** Place the Alignment point on the lower right-hand corner of the polygon and the Shear point on the upper right-hand corner.

**Outline the Truck  
with the Polygon  
Tool**

- Step 1** Change the eyepoint position to (0, 90, 0) and make sure Grid Snap is turned off in the View panel.
- Step 2** Set g2 as the Parent.
- Step 3** Use the Polygon tool (from the Face Tools toolbox) to outline the side view of the truck. Follow the shape of the truck, but do not include the wheels. The wheels should be made separately so they can rotate.

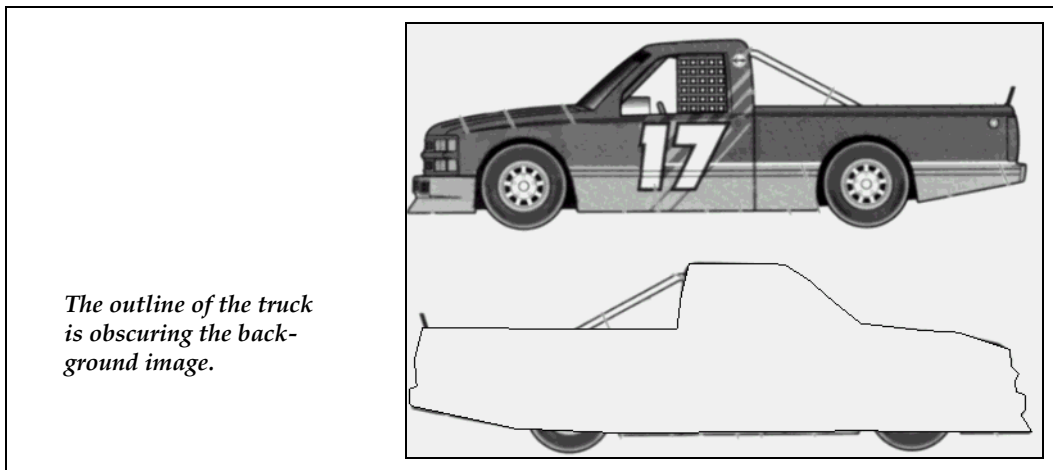

**Wall it up!**

- Step 4** When you have a polygon in the shape of the side of the truck, use the Wall tool to raise the side of the truck into a three dimensional shape. Use 11 for the width of the truck and uncheck the Keep Wall Bottom checkbox.



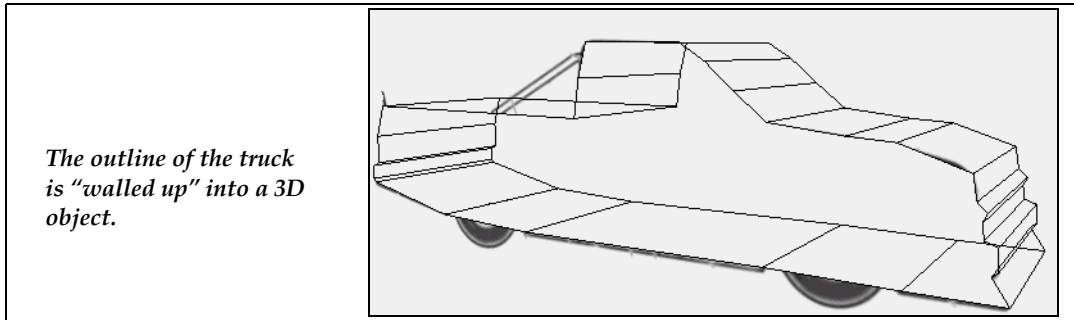

### Add Detail with Texture

Now we’ll map the same texture to the raised side of the polygon using Put Texture as follows.

**Step 1** Make sure textures is on (press the T key).

**Step 2** Make sure you are in Face mode.

**Step 3** Click the Put Texture tool from the Map Texture toolbox. (The diehard2 . jpg texture file should still be loaded in the Texture palette.)



**Step 4** In the *Put Texture* window, position the red, green, and blue points that represent Origin, Alignment, and Shear as carefully as possible on the side of the truck image. The Origin and Alignment points should be on the bottom of the back and front bumper. The Shear point should be directly above the Alignment point.

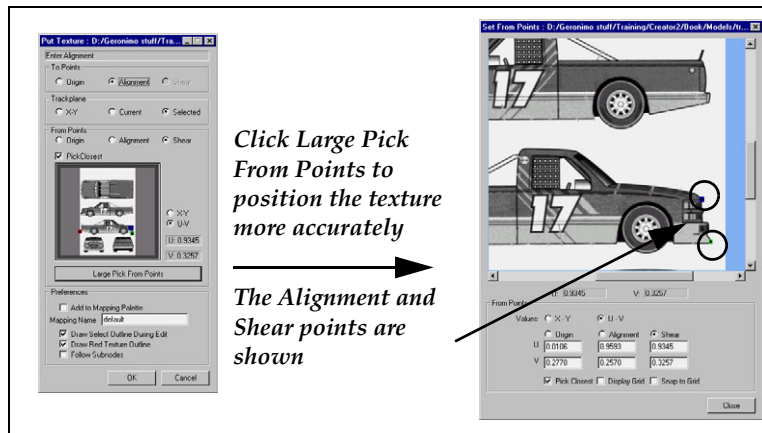

- Step 5** Click the Large Pick From Points icon to display the *Set From Points* window.
- Step 6** In the *Set From Points* window, precisely set the Origin, Alignment, and Shear for the From Points.
- Step 7** Click Close to return to the *Put Texture* window.
- Step 8** In the Graphics view, place the Origin, Alignment, and Shear points on the truck polygon in the same places that you placed the From Points on the truck image. Click OK.

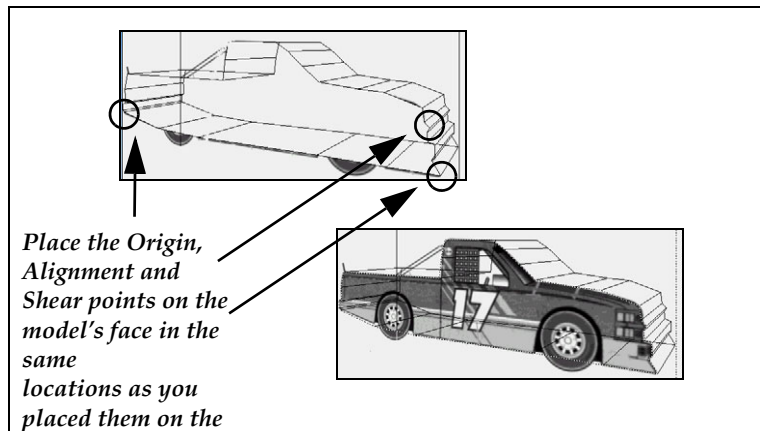

- Step 9** Repeat the texturing procedure to place textures on the front, back, top, and other side of the truck.

## Creating Tire Polygons

You can create tires for the model using the same Polygon and Wall technique. You'll have to cut well-wheels into the truck before you can position the tires.

- Step 1** Create a tire for the model using the same Polygon and Wall technique.
- Step 2** Apply textures to the tire.
- Step 3** Copy and paste the tire three times to make all four tires for the truck.
- Step 4** Use the Translate tool to move the tires into position.



As you can see, this vehicle is very boxy-shaped, because the Wall tool made the new sides perfectly parallel. The truck should be narrower at the top of the cab than it is at the bottom. You can use the Scale tool to make the top of the cab narrower so it curves in at a more realistic curved angle.

Change to Vertex mode and select the vertices at the top of the truck. Scale them in toward each other.

## *Tutorial — Cross-Sectional Modeling*

### **Modeling Goal**

This model illustrates cross-sectional modeling and the use of the Loft tool. You will learn how to make cross-sections from an image file and use the cross-sections to create a 3D model.

### **Modeling Objectives**

In this tutorial, we'll make a more detailed version of the same truck as in the last tutorial using the cross-section technique. To save time, a sample file is provided that already contains some cross-sections, which were made by outlining a background image using the Polygon tool.

### **Creating Truck Cross-Sections**

**Step 1** Open the `truck02.flt` file in the `\Program Files\Multigen-Paradigm/resources/tutorials/creator/DesktopTutor\Models (Windows)` or `/usr/local/MultiGen-Paradigm/resources/tutorials/creator/DesktopTutor/Models (IRIX)` directory. Make sure textures are turned on. You should be able to see the `diehard2.jpg` file, which has been mapped to a single polygon.

On the background polygon, several outlines of the truck have been made around key parts of the vehicle to form cross-sections. These cross-sections are on the lower right of the background polygon. Similar polygons are arranged on the left-facing truck image. In this exercise, you will align the cross-sections on the right-facing truck image.

**Note**

Here we are just building half of the truck. We will use the Mirror tool later to create the other half.

Press T to toggle the textures on and off. With the textures off, you can see the cross-sections of the truck in the lower right. In the upper part of the picture, the cross-sections are flipped up and positioned onto the left-facing truck

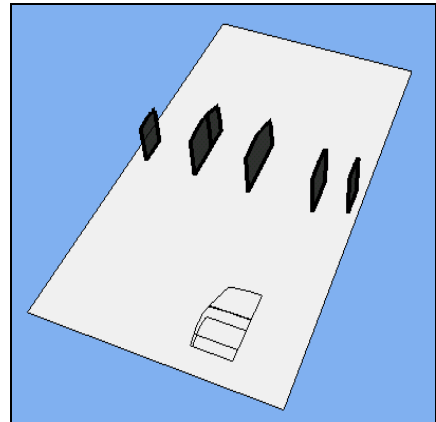
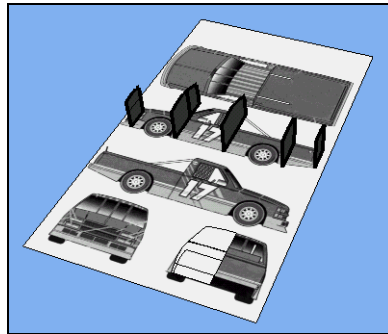

The polygons at the front and back of the cab are actually two polygons put together. The taller polygons will form the cab of the truck; the shorter polygons are used when lofting the bed and hood.

**Step 2** Change into Face mode, then select a cross-section.

**Step 3** Use the Rotate About Edge tool to flip the cross-section up 90 degrees (in the Z axis).



Start the Rotate About Edge tool, select the straight edge of the polygon, and then set the rotation to 90 degrees.

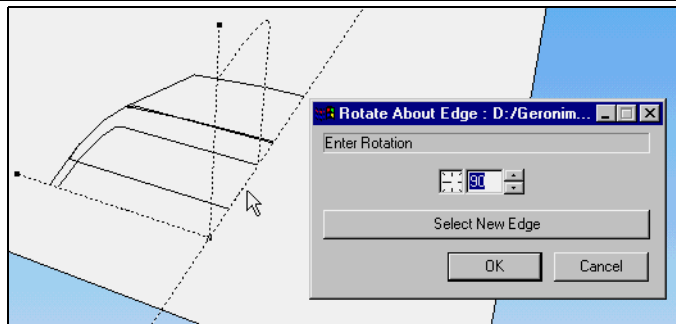
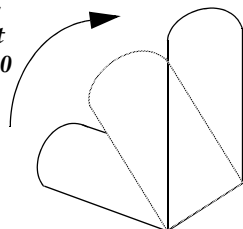

Align to  
Background Image

**Step 4** To make the cross-section easier to see, change the line style to a thicker weight. Double-click the cross-section to display its *Face Attributes* window. Click the Drawing tab and enter 1 in the Line Style field.

**Step 5** Translate the cross-sections to position them correctly on the right-facing truck image. When you translate them, freeze the Z axis, so it is easier to keep them on the background polygon.

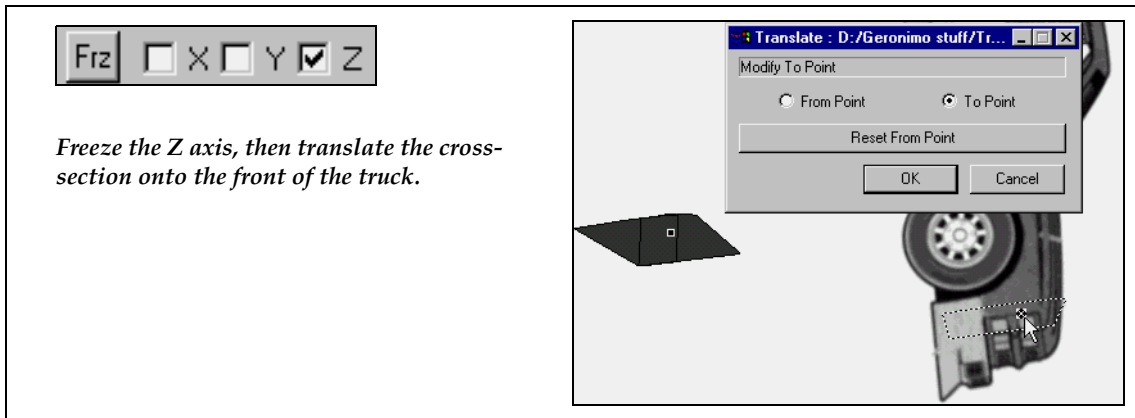

**Step 6** Repeat the steps above for each of the cross-sections. When you are done, unfreeze the Z axis by unchecking the checkbox.

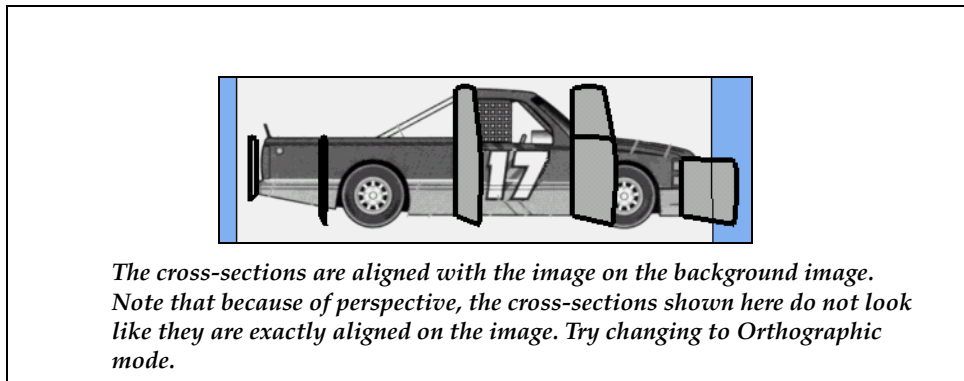

## Lofting the Cross-Sections

In this exercise, the polygons on the left-facing truck image are used to demonstrate lofting. You can do the same or use the polygons you lined up on the right-facing truck.

When the polygons are lined up correctly, select faces and loft them together in a series of lofts. You may find it easier to hide or move the background polygon to make selecting faces easier.

**Step 1** Set g2 as the Parent node.

**Step 2** Set the modeling mode to Face mode, and select p16 and p17. Use the Loft tool in the Geometry Tools toolbox to loft the hood of the truck.

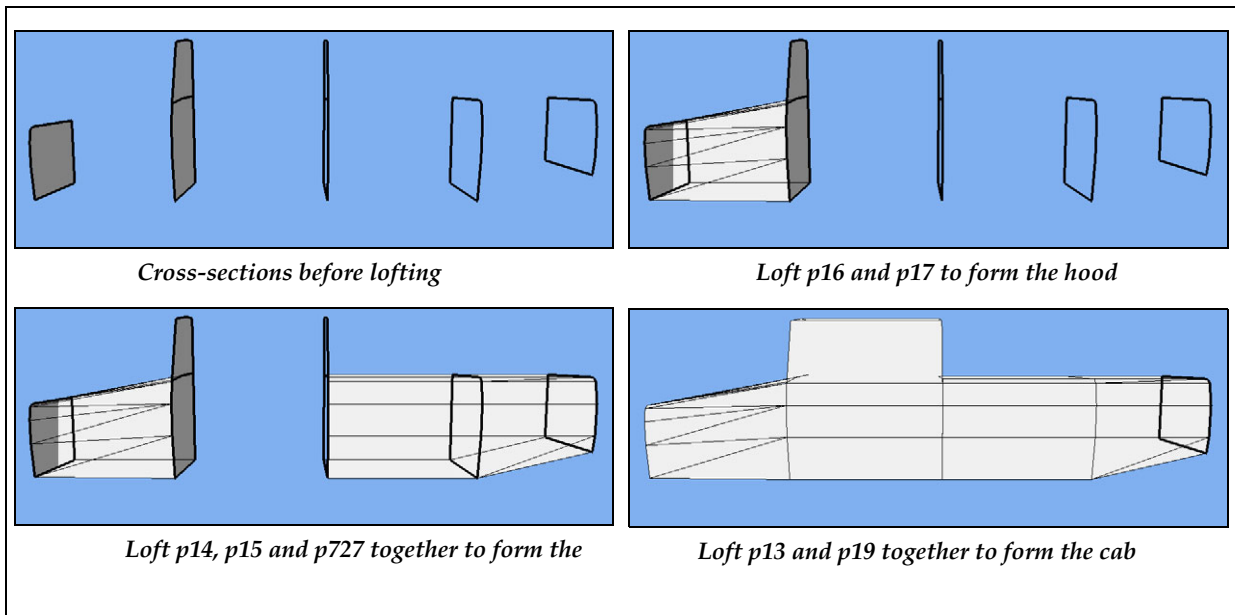

**Step 3** Select p14, p15, and p727 and click **Loft** to form the bed of the truck.

**Step 4** Select p13 and p19 and click **Loft** to form the cab of the truck.



## Fine-Tuning the Shape by Moving Vertices

- Step 1** Change into Vertex mode and select the three vertices at the top of the windshield.
- Step 2** Freeze the Y and the Z axis. Then select the Modify Vertex tool from the Modify Vertex toolbox.

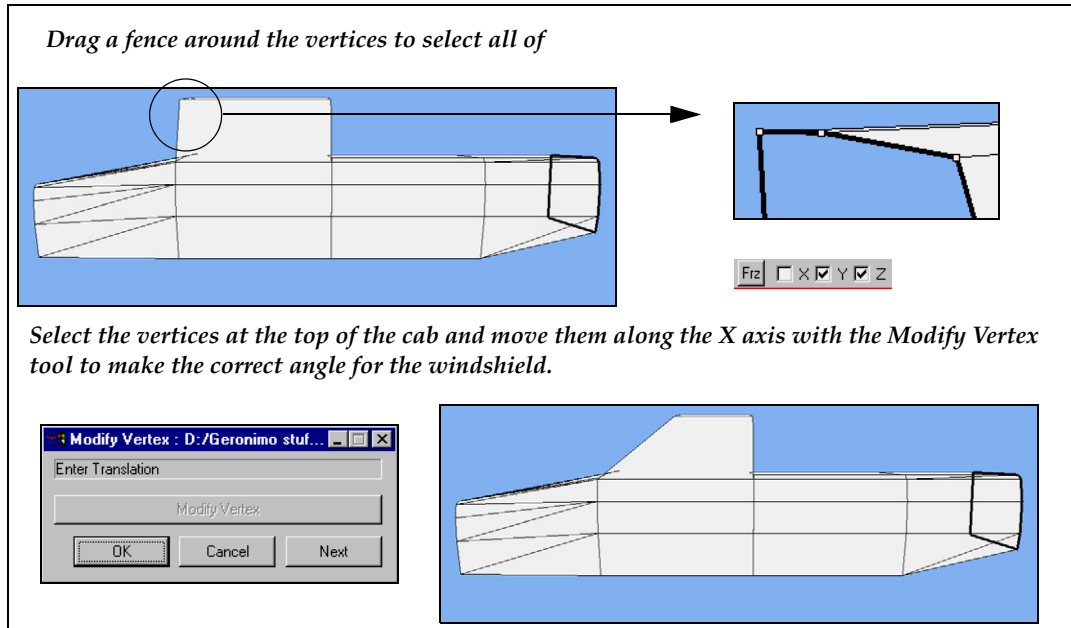

- Step 3** In the Graphics view, slowly drag the vertices to the right with the middle mouse button until the angle of the windshield matches the original. You can use the left mouse button if you first turn off Snap to Grid in the View panel.

---

### Note

Note that the Modify Vertex tool allows you to preview different angles as you drag the mouse, unlike the Translate tool, which can also be used to move vertices.

---

- Step 4** Delete the cross-sections and any unneeded faces. The goal is to reduce the number of faces to the absolute minimum.

### **Tweaking the Model**

Further steps are necessary to finish this model. You must cut out the wheel wells and then add detail with subfaces, materials and other additional polygons. These steps are not shown here.

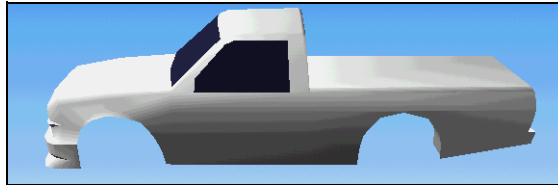

*Add additional detail and cut out wheel wells to form a higher-detailed version of the model*

When you have added sufficient detail, you will have completed the driver's side of a truck. Use the Mirror tool to make the other side of the model. By using this technique of creating one-half of a model and then mirroring it, you can quickly make a bilaterally symmetrical model. Mirroring is demonstrated in the next section.



## Mirror the Truck

In this exercise, use the Duplicate tool to make a copy of the half-truck model and then use the Mirror tool to flip the driver's side of the truck to become the passenger side of the truck. To place the passenger side in the correct position, you must use the tracking plane.

- Step 1** From the Duplicate toolbox, click the Duplicate tool.
- Step 2** Turn on the grid.
- Step 3** In Face mode, select the face on the top of the truck bed.

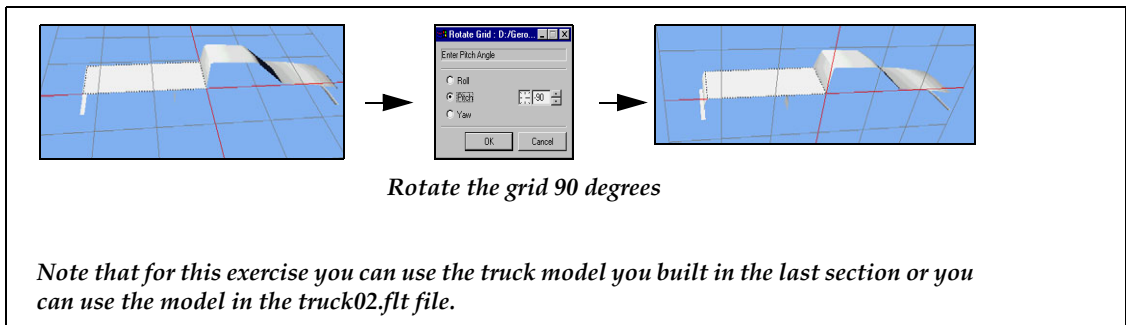

- Step 4** In the View panel, click Rotate Grid. Select Pitch and set the clock setting to 90 degrees. This rotates the grid so it is flush with the unfinished side of the truck.
- Step 5** Change to Group mode, and then select Duplicate from the Duplicate toolbox.
- Step 6** In the *Duplicate* dialog box, click OK. This places the duplicate in the same place as the original.
- Step 7** Select Mirror from the Modify Geometry toolbox.
- Step 8** The duplicate is now mirrored on the other side of the tracking plane.
- Step 9** Choose *Edit/Combine Faces* to combine any planar faces, such as the bed cover and roof, to decrease the polygon count.

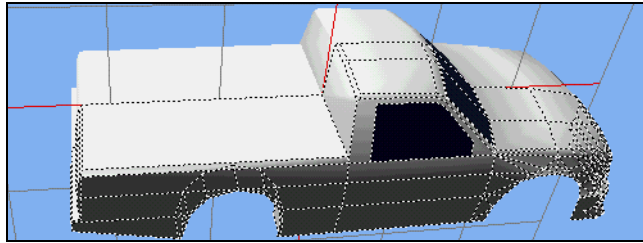

**Pit Stop**

With tires and textures added, here's what the final truck looks like.



## *Making a 3D Template*

Using a background image on a polygon does not have to be limited to two dimensions. You can take several polygons with different views of a model mapped to them and create a 3D template, which is used to match a model's dimensions to the dimensions of the scanned image.

This technique involves using three or more polygons representing the height, width, and depth of the model. These polygons have the scanned image mapped onto them. Then the polygons are made semi-transparent so you can see through them to the model you are creating.

*These semi-transparent polygons are mapped with the truck texture. The model is shown inside the cube in this three-quarter view.*

*Open the truck02.flr file to examine this cube*

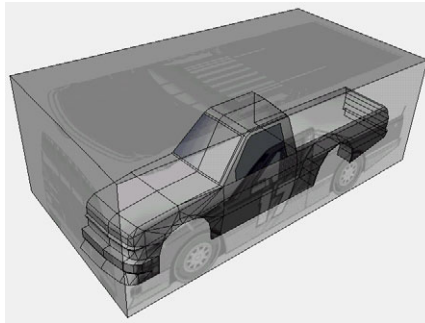

*Front view of the cube, in perspective view. Note that only half of the truck is shown inside the cube.*

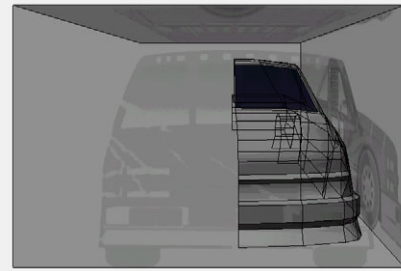

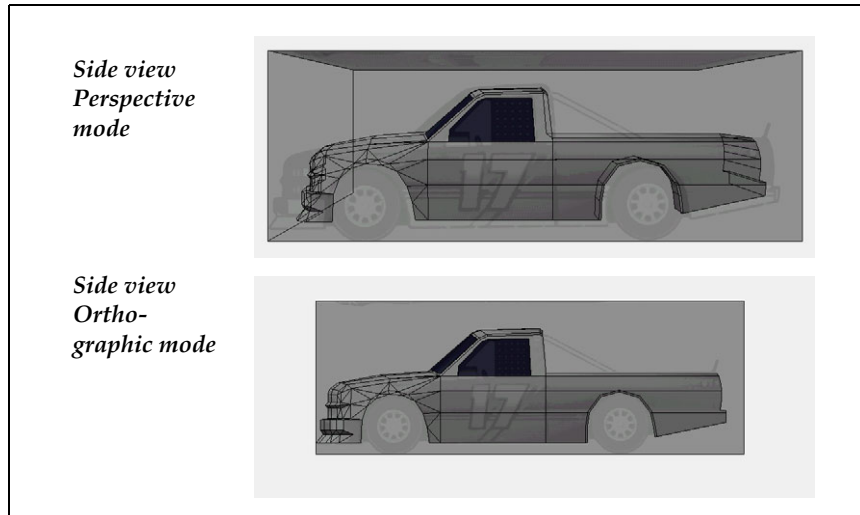

You should note several important points when using this modeling technique.

### **Tips for 3D Templates**

- **Orthographic mode works best, since it avoids the foreshortening effect of perspective mode.**
- **Create the polygons and make both sides visible. Then use the Reverse Face tool on each face before mapping the texture to it. This allows you to select the face of the model, not the face of the polygon as you work on the model. In effect, you are reaching through the polygon (the cube wall) to the model.**
- **Set the transparency for each polygon to .5, which is half way between transparent and opaque.**
- **Note that all of the polygons use a single texture file. Each polygon references a different part of the same file (diehard2.jpg).**
- **When applying the texture with the Map Texture tool, be careful not to distort the image to fit on the polygon. Each view needs to have the same scale.**



To examine this example more closely, open the `truck02.flr` file in the `\Program Files\Multigen-Paradigm/resources/tutorials/creator/DesktopTutor\Models (Windows)` or `/usr/local/MultiGen-Paradigm/resources/tutorials/creator/DesktopTutor/Models (IRIX)` directory.

## Bounding Volumes

Bounding volumes are an attribute of Group nodes. Their size and shape are controlled with the *Group Attributes* window.

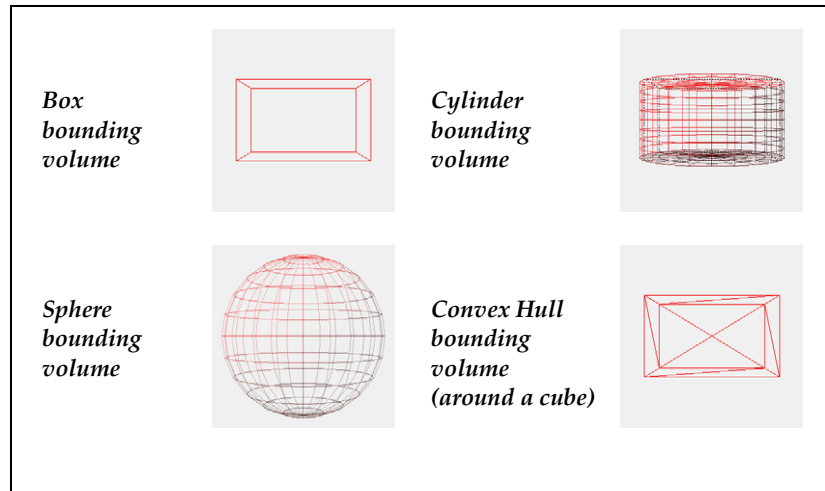

Different types of bounding volumes enclose more or less space around an object or group of objects.

For collision detection, choose a bounding volume that closely matches the object; otherwise, the collision might take place before the objects actually touch!

### Types of Bounding Volumes

Choose a bounding volume to match your needs:

- A Box bounding box works well with single objects but may not fit well on non-rectangular objects.
- A Sphere bounding box works best with round objects.

## 8 Constructing Vehicles

### Bounding Volumes

- A Cylinder encloses objects with a circular shaped bounding volume that has flat tops and bottoms. This shape is sometimes used for cities in flight simulations where the bounding box detects missile strikes.
- A Convex Hull shrink-wraps objects with the smallest possible bounding volume.
- A Histogram is used for certain types of gaming programs.

### Creating and Customizing Bounding Volumes

To create a Bounding volume, you must first create one or more objects under a Group node. These objects may be related for collision detection purposes, for example, the wheels on a car. Once the objects are positioned under a common Group node, create the bounding volume and customize its shape.

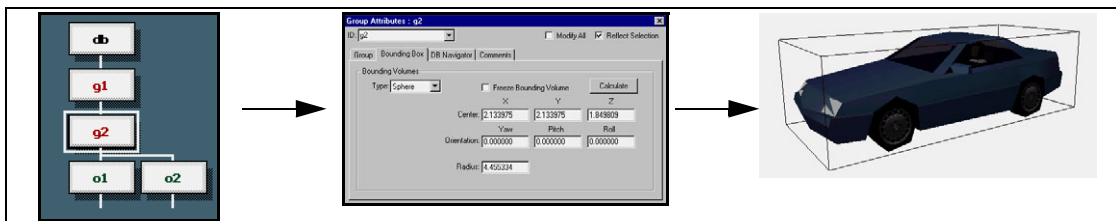

### Try it!

In this example, open the truck file you built in the previous section, then make its bounding box visible and adjust its dimensions.

**Step 1** Open the truck file you created in the last section, or open *truck02.flt* in the `\Program Files\Multigen-Paradigm\resources\tutorials\creator\DesktopTutor\Models (Windows)` or `/usr/local/MultiGen-Paradigm/resources/tutorials/creator/DesktopTutor/Models (IRIX)` directory.

**Step 2** Open the *Group Attributes* window for the Group node that includes the truck and select a Cylinder bounding volume.

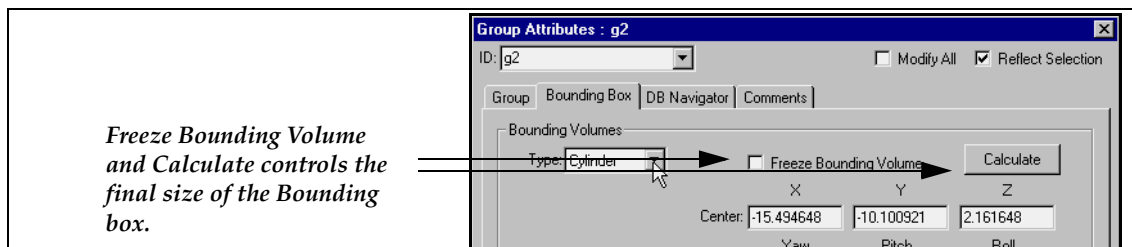

## Make it Visible

**Step 3** Use the Draw Bounding Volumes icon in the View Panel to make the viewing volume visible.

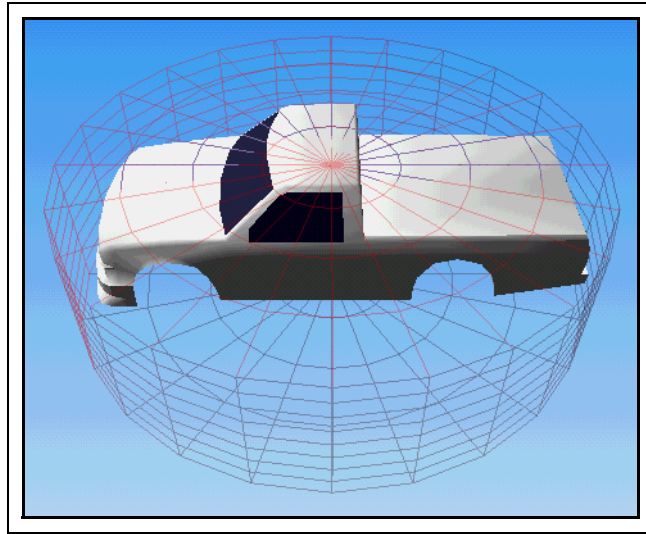

## Change its Size

**Step 4** Adjust the X and Y values in the *Group Attributes* window to make the bounding volume smaller.

**Step 5** Try other shapes for the Bounding Volume type. If you change the shape to a box shape, your model should look something like this.

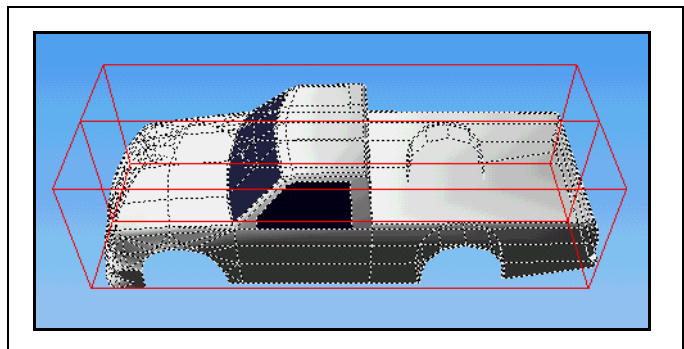

The box-shaped bounding box fits the truck model exactly and will give more realistic performance when used for collision detection.

## **Bounding Volume Offsets**

You can position the bounding volume anywhere in relation to the model. In this exercise, you'll set the bounding volume slightly above the model. To position the bounding volume more precisely, we'll use the tracking plane.

This bounding volume position could be used by the realtime system to detect collisions from above slightly sooner than collisions from the front or the back.

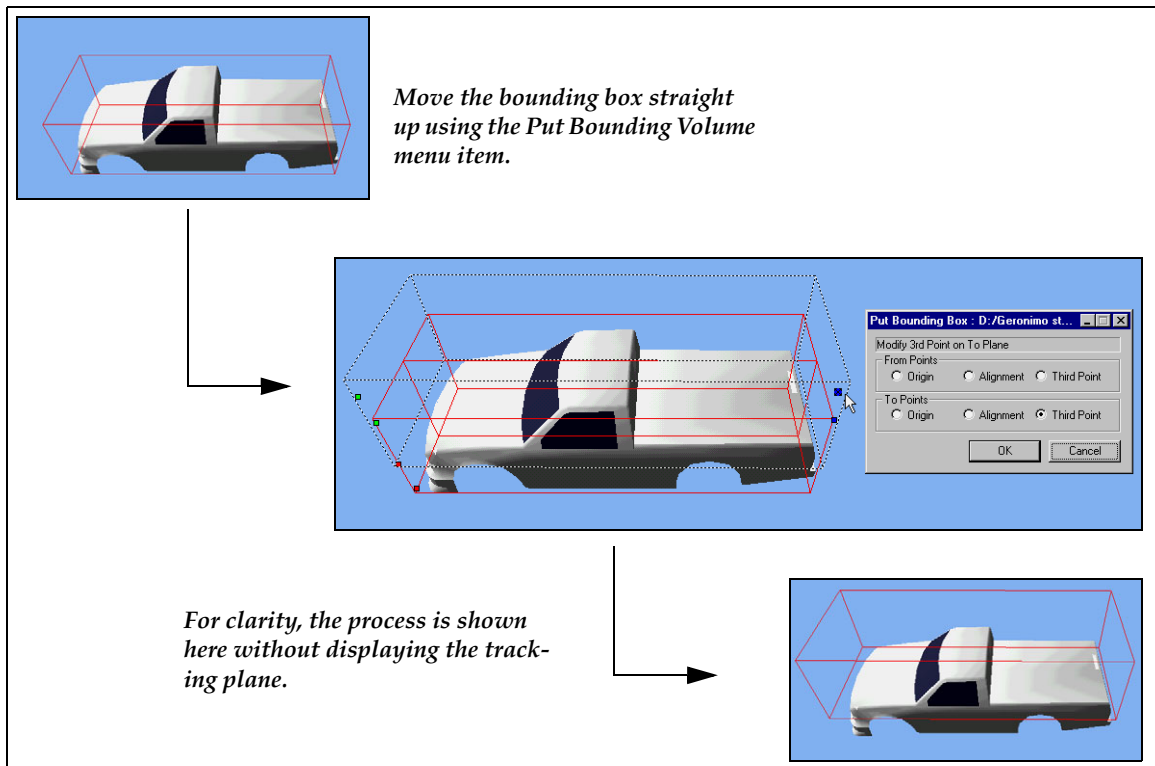

## Step by Step

Follow this procedure to change the position of the bounding volume.

**Step 1** Turn off Grid Snap to make it easier to set the points.



**Step 2** Click Grid on/off to display the tracking plane.



**Step 3** Make sure you still have the Group node for the truck selected.

**Step 4** Set the tracking plane to YZ and use VTX to set it against the front of the bounding volume.

**Step 5** Choose *Attributes/Put Bounding Volume* to move the Bounding Volume. In the *Put Bounding Volume* dialog box, middle-click Origin, Alignment points at the top front corners of the bounding volume, and the Third Point at the bottom front of the bounding volume.

*First set the three points on the bounding volume, then set the Origin, Alignment, and Third Points on the YZ tracking plane.*

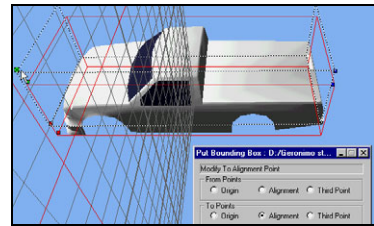

**Step 6** Click points on the tracking plane to set the Origin, and Alignment points above the model. Note that the location of the Alignment point on the tracking plane also scales the size of the bounding box.

**Step 7** Click a Third Point on the tracking plane.

**Step 8** Click OK to finish.

## Shrink-Wrap it!

You may want a very small bounding volume that is set as close as possible to the polygons. This shape has the advantage of allowing the most precise collision detection possible with bounding volumes.

- Step 1** Select the Group node and press **Ctrl + =** to display the **Group Attributes** window.
- Step 2** Click the **Bounding Box** tab and change the bounding volume **Type** to **Convex Hull**. This shape is the minimum shape necessary to surround the model. It is a shrink-wrapped bounding volume.

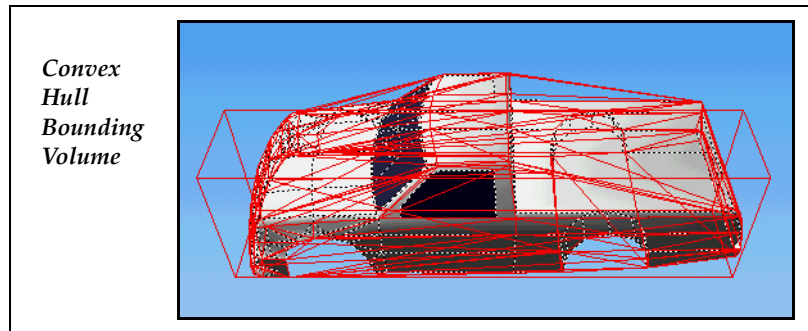

Although the Convex Hull may fit the truck model more precisely, it may slow down performance in the realtime system because it has more polygons to process. Try different bounding volume shapes to compare the frame rate in the realtime system.



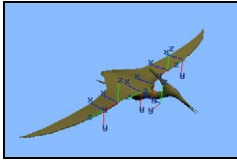

## Degrees of Freedom

### Introduction

Virtual worlds need both static and moving models. Moving models must move like their real world counterparts, if they have one! To achieve realism, a tank's turret must spin, a wheel must rotate, or a human leg must bend and hinge normally. These motions are *defined* and *constrained* for each moving model with Degree of Freedom (DOF) nodes.

DOF nodes define a model's movement and its constraints with a DOF node in the hierarchy. When a DOF node is a child of another DOF node, it inherits the parent node's movement definitions and restraints in motion. You can define the motion for ankle joint movement in a leg, which inherits the movement of the knee node, which in turns inherits definitions and constraints from the hip node. This combination of definitions and constraints can replicate a walking motion, which you will see in the Walker Vehicle tutorial.

### Contents

<b>DEGREE OF FREEDOM TOOLS</b>	164	DOF Attributes Window	179
<b>CREATING AND POSITIONING DOF NODES</b>	165	<b>TUTORIAL — THE CRANE</b>	180
Get Started	165	<b>MODELING GOAL</b>	180
Create a Box	165	<b>MODELING OBJECTIVES</b>	180
Create the DOF Hierarchy	167	<b>TUTORIAL STEPS</b>	180
Position the DOF Coordinate System	169	Create the DOF Node	181
Set the DOF Limits	171	Position the DOF	181
Exercise the Limits	174	Set the Limits	182
Animate the Limits	175	Exercise the DOF	183
Modify the DOF Position	176	Independent Experiment	184
Freezing a DOF	177		
Clearing DOF Limits	178		

## *Degree of Freedom Tools*

DOF tools consist of a special node type, a mode, and related tools that provide for the positioning and control of component motion.

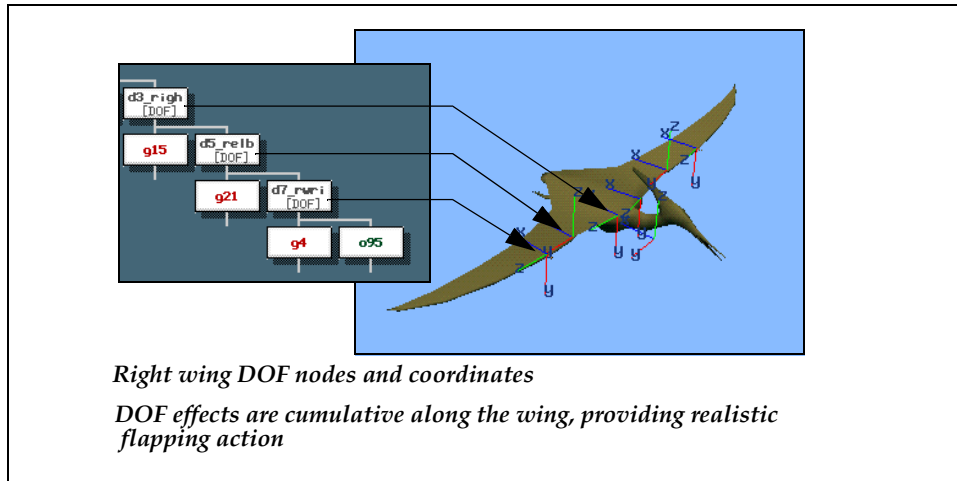

- The key element is the DOF node, which represents a self-contained local transformation matrix. Through its attribute window and dialog box, limits of rotation, scale, or translation motion can be defined for each axis of freedom.
- All attached children are affected by the transformations and limits imposed by the DOF node.

In the example above, DOF nodes located at the segments of each wing of the pteranodon mark the points of articulation in each wing, and control the limits of each articulation. Because they are hierarchically related, each segment is affected by its parent segments, preventing accidental segment separation.



## Creating and Positioning DOF Nodes

DOF nodes are created using the **Create DOF** tool. Because the placement of the DOF determines the center of rotation and scale for the node's children, the DOF must be positioned at the point of articulation using the **Position DOF** menu option.

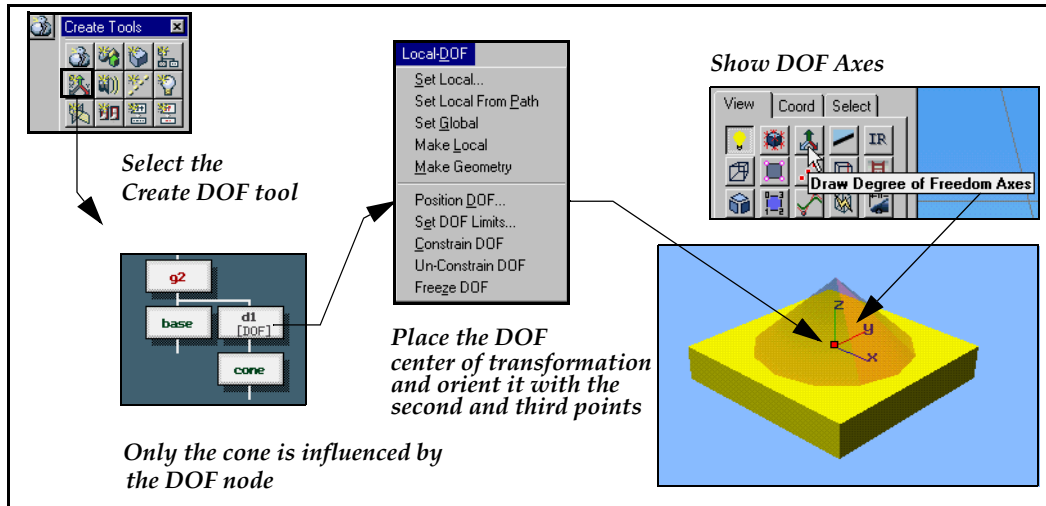

In the following exercise, you will create a DOF to move a box top up and down

### Get Started

- Step 1** Open a new file.
- Step 2** Split the window horizontally to view both the Graphics and Hierarchy views.
- Step 3** Notice that g2 is already set as the parent.

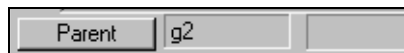

### Create a Box

- Step 1** Choose Object modeling mode.

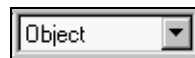

- Step 2** Open the Face toolbox and click the Rectangle tool.

## 9 Degrees of Freedom

### *Degree of Freedom Tools*

**Step 3** Enter two points on the grid to create a square, and then click OK.

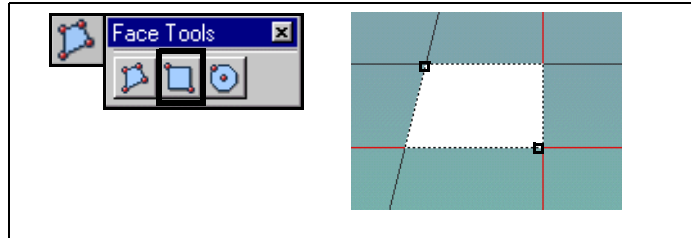

**Step 4** Open the Geometry toolbox and click Wall (Shift+W).

**Step 5** Click OK to construct a wall at the default Wall Height. Be sure Keep Wall Bottom is set. You should now have a box that looks similar to this:

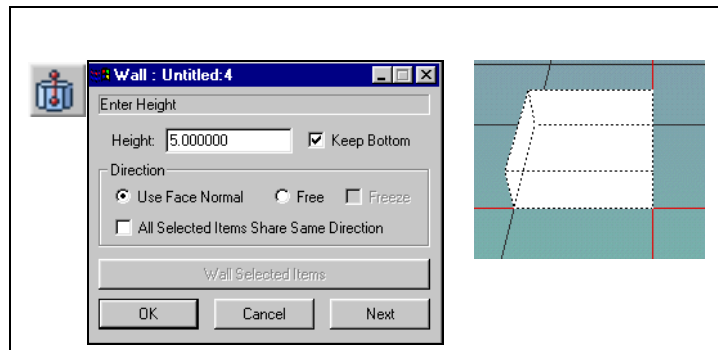

The database structure should look like the following illustration. (Middle-click in the Hierarchy view to display the faces.)

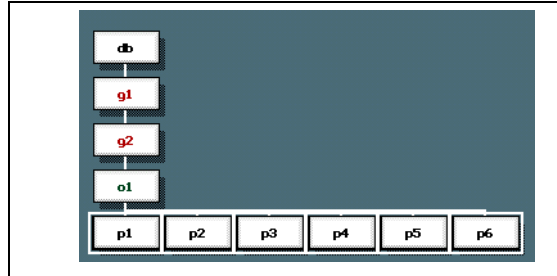

**Step 6** Save your file (Ctrl+S) as `box.flt`.

**Step 7** Click the View Panel button in the Toolbar.

**Step 8** Click anywhere in the Graphics view to activate the View controls, and then click the Grid button to turn off the grid. This will make it easier to see your axes placement in the next part of the exercise.

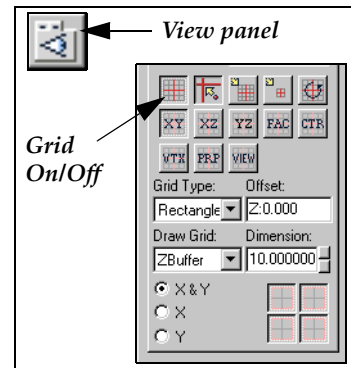

## Create the DOF Hierarchy

All objects and faces that are going to move must be children of the DOF node that controls their movement. In this procedure, you will create a DOF node, and make the box top a child of the DOF node.

**Step 1** Select `g1` and click the Parent button at the bottom of the window to set `g1` as the new parent.

**Step 2** Open the Create toolbox and drag it away from the Toolbox caddy to keep it open.

## 9 Degrees of Freedom

### *Degree of Freedom Tools*

**Step 3** Click Create DOF. The new DOF node (d1) appears as a child of g1.

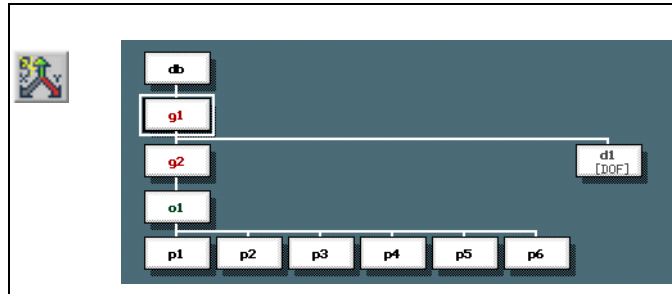

**Step 4** Select d1 and click the Parent button at the bottom of the window to set d1 as the new parent.

**Step 5** Click Create Object in the Create toolbox. The new object appears as a child of the DOF node. Close the Create toolbox.

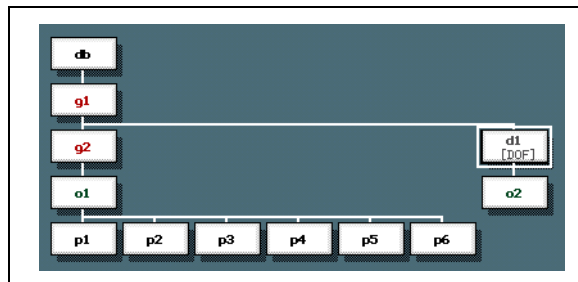

---

### Note

You create the new object node to avoid attaching a face node to the DOF node in Step 8 of this exercise. A DOF node has the same hierarchy value as a group node. Some realtime systems will discard face nodes that are attached directly to group nodes or their equivalents in the hierarchy.

---



- Step 6** Set the modeling mode to Face using the menu in the Toolbar.
- Step 7** Select the top face of the box. The node (p1) is now selected in the Hierarchy view.
- Step 8** Drag p1 onto the object node that is a child of the DOF node (o2), and release the mouse button.

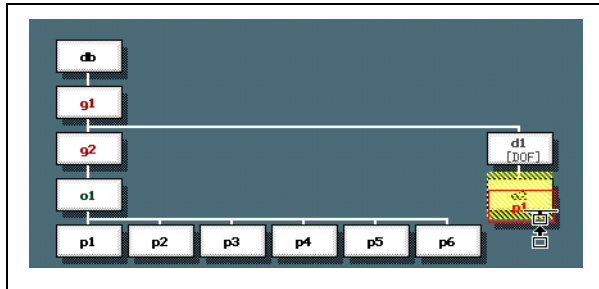

**P1 is now a child of O2.**

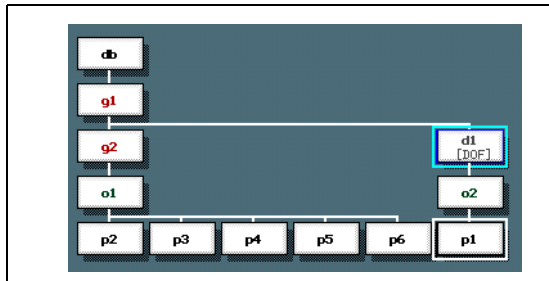

- Step 9** Save your file (Ctrl+S).

### Position the DOF Coordinate System

This part of the exercise establishes the local coordinate system for the DOF. All movement controlled by the DOF node is based on this local coordinate system.

## 9 Degrees of Freedom

### *Degree of Freedom Tools*

- Step 1** Click anywhere in the Graphics view to activate the View panel.
- Step 2** Click Draw DOF Axes to display the DOF axes in the Graphics view. The initial position for any DOF you create is at the database origin (0, 0, 0).

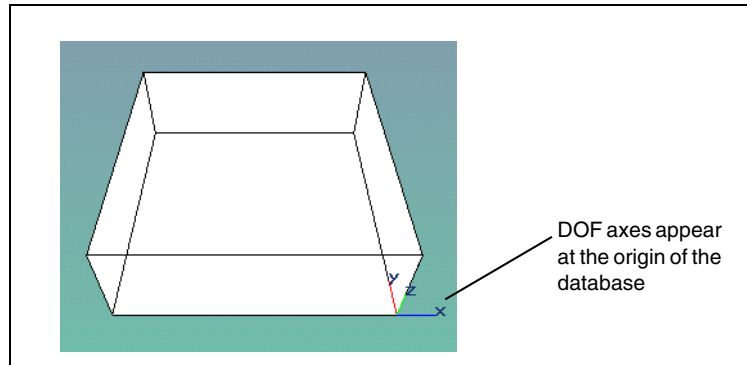

- Step 3** Select the DOF node d1. Notice that the DOF node is outlined in white and that the DOF axes display turns white when the DOF is selected.
- Step 4** Choose Local-DOF/Position DOF. The *Position DOF* dialog box appears.
- Step 5** Middle-click the upper-right corner of p1. This positions the local origin of the DOF at the corner vertex.

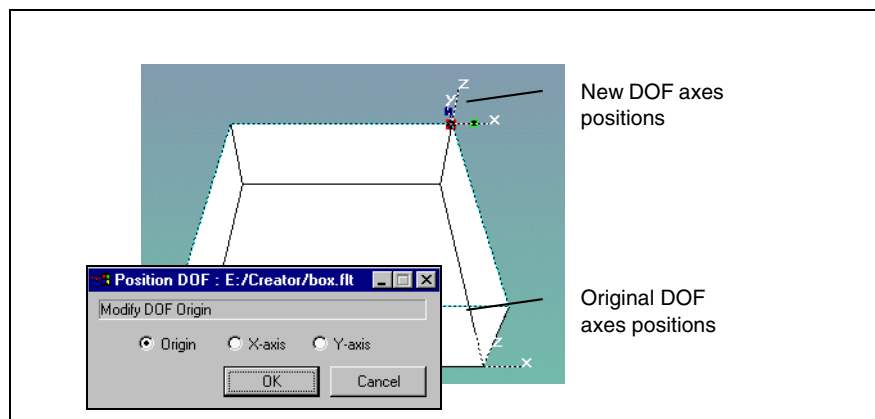

Notice that an axis display remains at the original position, to show where the axes would be positioned if you canceled the Position DOF operation.

- Step 6** In the *Position DOF* dialog box, select X-axis and then, in the Graphics view, middle-click the back edge of p1 to position the x-axis along that edge. (Middle-clicking ensures that the axis is aligned with the edge.)

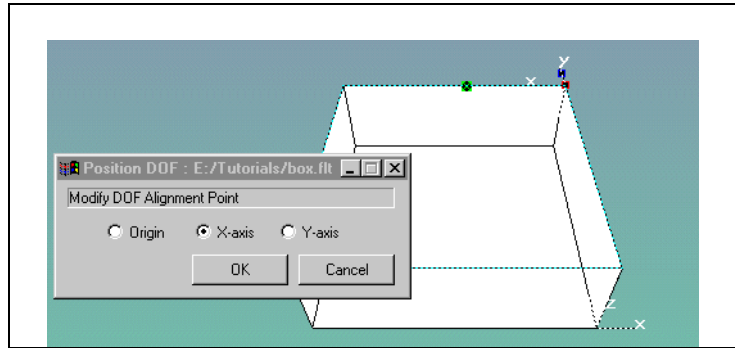

- Step 7** Select Y-axis and middle-click the right edge of p1 to position the y-axis of the DOF, and then click OK. Notice that the z-axis is still pointing upward. You have simply rotated the x- and y-axes so that the positive values are now along the edge of the box top.

- Step 8** Save the file (Ctrl+S).

## Set the DOF Limits

Unique motion limits can be assigned to a DOF node's degrees of freedom in the Set DOF Limits dialog box. Values can be entered in the dialog box's text fields, or graphically entered by dragging the control points with your mouse.

In this exercise, you will set limits to make the box top open and close. To do this, the top of the box will rotate around the *y*-axis, which is positioned along one edge of the box top. Movement around the *y*-axis will be limited to a range of motion between the minimum and

## 9 Degrees of Freedom

### *Degree of Freedom Tools*

maximum angles you define. Movement along the  $x$ -axis and  $z$ -axis will be disallowed by constraining the movement to zero along these axes.

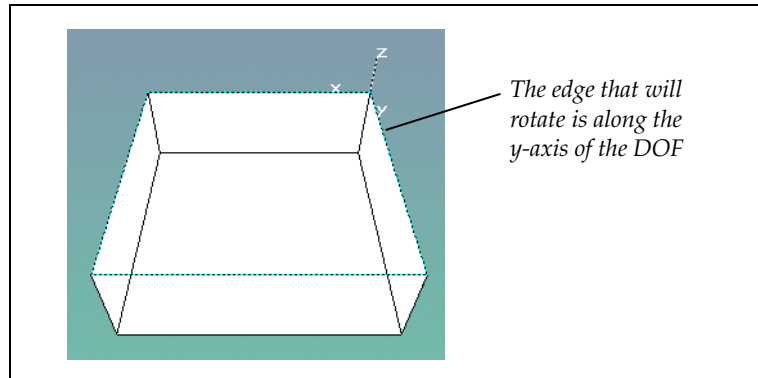

**Step 1** With the DOF node still selected, choose Local-DOF/Set DOF Limits. The *Set DOF Limits* dialog box appears.

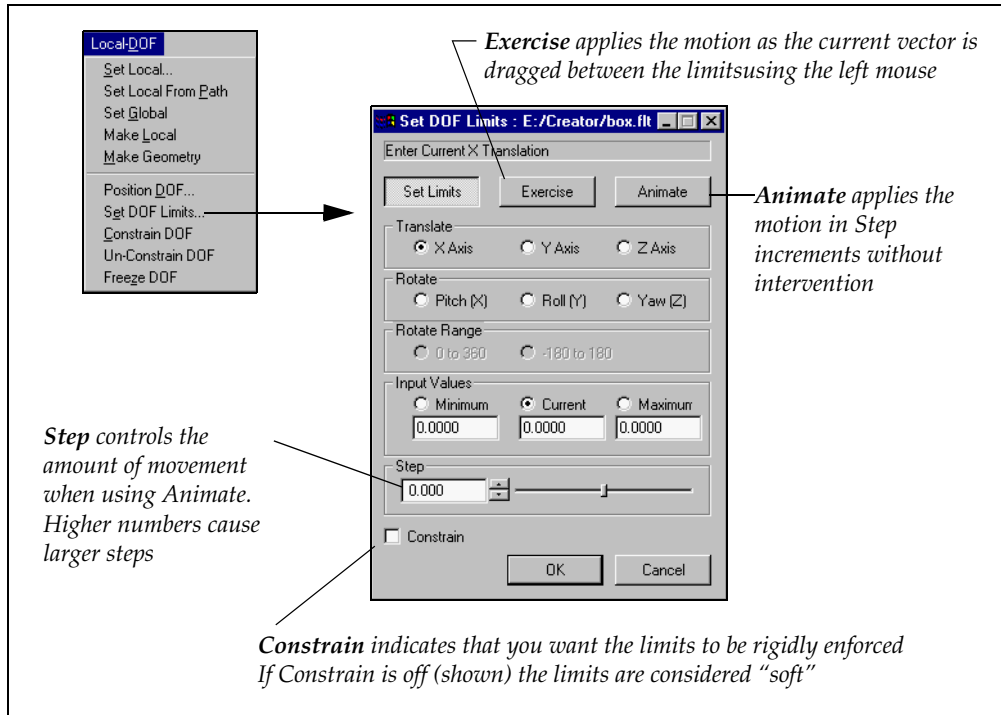

**Step 2** In the Rotate area, select Roll (Y).

**Step 3** For the Input Values, set Maximum to 90.

**Step 4** Set Step to 1.

**Step 5** Set the Constrain checkbox. Do not click OK yet, because you are going to test the new limits in the same dialog box.

**Exercise the Limits**

**Step 1**

Click Exercise in the *Set DOF Limits* dialog box. The Graphics view shows the range of motion you specified when you set the DOF limits.

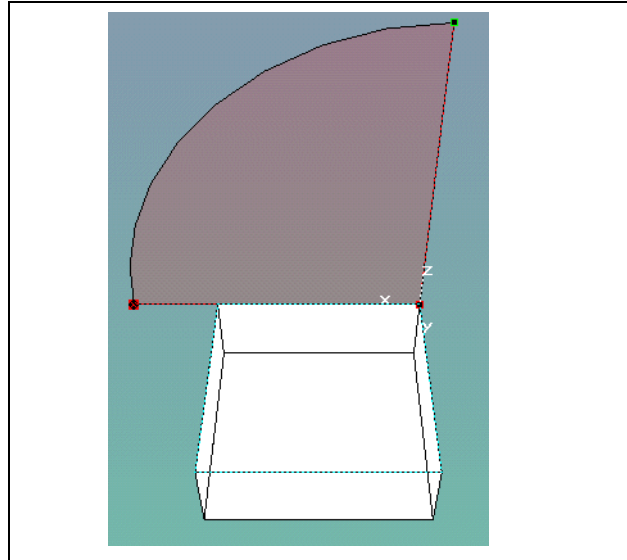

**Step 2** Drag the pointer in the Graphics view to see the movement of your model.

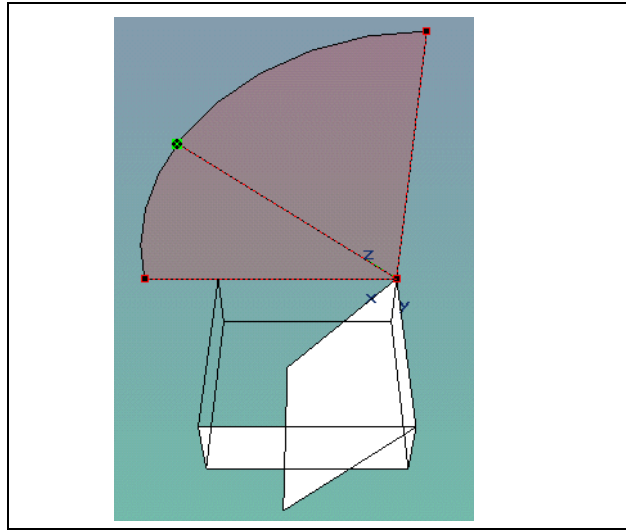

### Animate the Limits

**Step 1** In the *Set DOF Limits* dialog box, click *Animate*. Watch as the box top goes through the specified range of motion.

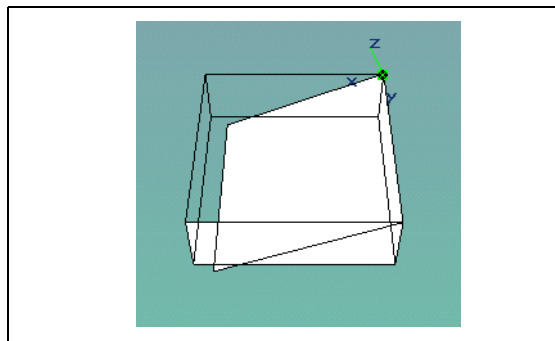

Notice that the box top has the correct range of motion, but the rotation is in the wrong direction. This must be fixed by modifying the position of the y-axis of the DOF, which we will do in the next part of the exercise.

**Step 2** Click *OK* to accept the current limits and close the dialog box.

**Step 3** Save the file (Ctrl+S).

## Modify the DOF Position

The box top in the example moves inward. We want the top to open up and out, so we have to reverse the positive direction of the axis around which the top rotates; in this case the y-axis. To do this:

- Step 1** In the Hierarchy view, select the DOF node.
- Step 2** Choose Local-DOF/Position DOF. The Position DOF dialog box appears.
- Step 3** Select Y-Axis.
- Step 4** Middle-click the edge of the box top along the y-axis and drag the pointer towards the back of the box, past the x-axis. This reverses the positive direction of the y-axis.

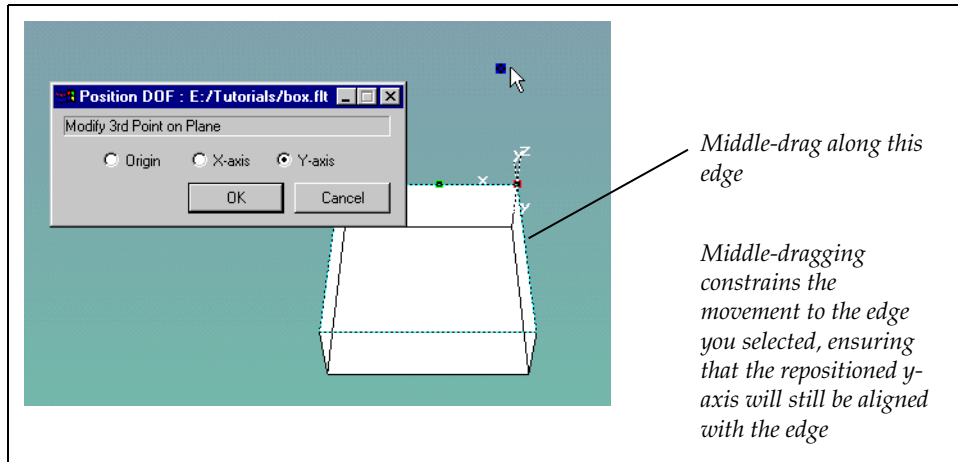

- Step 5** Click OK in the Position DOF dialog box.
- Step 6** Choose Local-DOF/Set DOF Limits to open the *Set DOF Limits* dialog box.



**Step 7** In the Rotate area, click Roll (Y). The limits you set previously should be displayed.

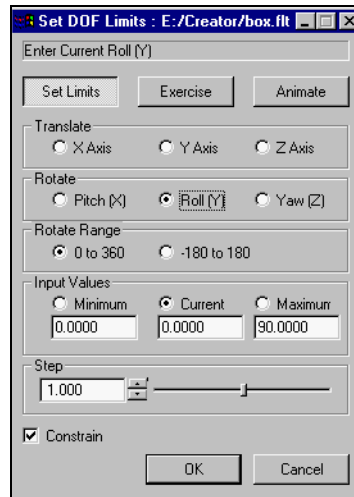

**Step 8** Click Animate, and confirm that the box top is now opening up and out.

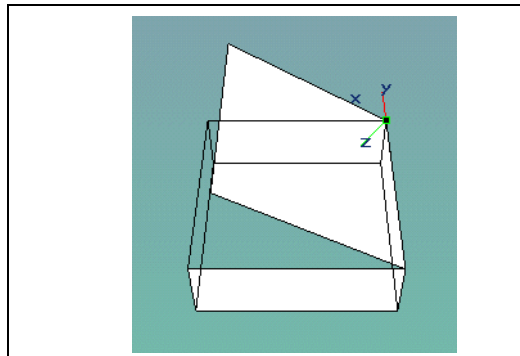

## Freezing a DOF

The Local-DOF menu command *Freeze DOF* sets the minimum and maximum values to the current values, eliminating the range of motion, and then sets the Step values to zero.

To see how this works, try this:

- Step 1** In the Rotate area, click Roll (Y) and set the Minimum and Maximum values to 0 and 180.
- Step 2** Set Step to 2, and move the box top just above the Minimum limit (about 20).
- Step 3** Click OK in the *Set DOF Limits* dialog box. Note the box top has been left at its new current position.
- Step 4** Choose *Local-DOF/Freeze DOF*.
- Step 5** Open the *DOF Attributes* window and click the Rotate tab. The Minimum and Maximum Yaw fields are set to the Current value (20), and Step is now set to zero. The DOF node is effectively frozen in one position.

To undo a Freeze DOF command, clear the Constrain checkbox in the *Set DOF Limits* dialog box and reset the values again to the desired setting.

### **Clearing DOF Limits**

To remove all DOF limits, clear all the input values in the *Set DOF Limits* dialog box. You can also clear these values in the *DOF Attributes* window.



## DOF Attributes Window

Another way to see and change DOF values is to use the *DOF Attributes* window. The *DOF Attributes* window is opened by double-clicking the DOF node or by selecting the node and choosing *Attributes/Modify Attributes* (Ctrl+=). The attributes of a DOF node place limits on translation, rotation, and scale motion in each of the three axes. Speed of motion is determined by the Step parameter. The starting or current position is contained in the Current field.

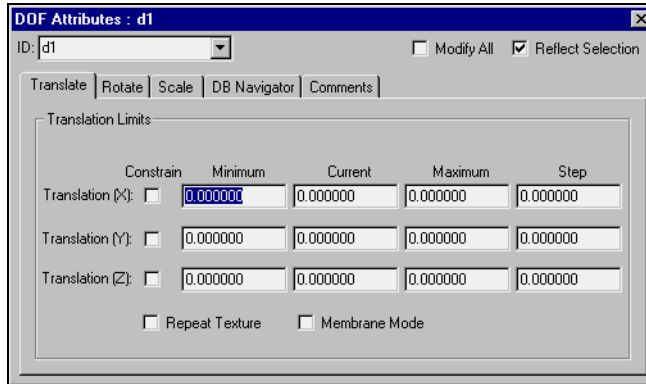

Double-click the DOF node to display this DOF Attributes window

- Minimum** Indicates the minimum position in which the DOF bead's child object can be placed, scaled, or rotated in the relevant axis.
- Maximum** Allows for maximum reach or rotation of an object in the relevant axis.
- Current** Indicates the starting position, or current placement, of the object between the minimum and maximum limits.
- Step** Shows the speed of motion expressed in degrees of rotation, units of scale, or increments of translation. When exercising the DOF, the current graphics position of an object is moved each step as the current control point is moved beyond the next step increment.

DOF attribute parameters may be typed into the fields in the *DOF Attributes* window or modified in the *Set DOF Limits* dialog box.

## *Tutorial — The Crane*

### **Modeling Goal**

You will now add degrees of freedom to the turret and boom of an industrial crane and set appropriate motion limits. At the end of this session, you will be able to place DOF nodes and apply proper limits to any point of articulation in any model.

### **Modeling Objectives**

This model illustrates articulation and the use of the tools and database elements related to articulation.

- **Creating DOF nodes**
- **Positioning a DOF center of rotation**
- **Setting practical limits on DOF ranges of motion**
- **Exercising and animating DOF motion**

### **Tutorial Steps**

The following steps create DOF nodes for a crane, articulating its turret and boom . The turret will rotate in a circle and the boom will raise and lower.

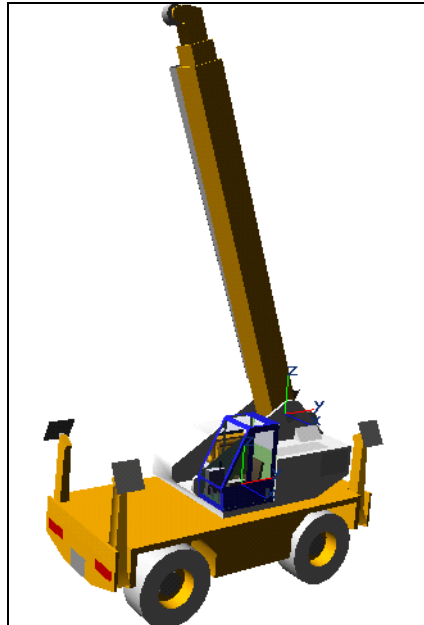

## Create the DOF Node

**Step 1** Open the file *crane.flt*. For Windows this file is in the `\Program Files\Multigen-Paradigm\resources\tutorials\creator\DesktopTutor\Models` directory. For IRIX, it is in `/usr/local/MultiGen-Paradigm/resources/tutorials/creator/DesktopTutor/Models`.

The object of this exercise is to rotate the turret of the crane.

**Step 2** Drag the window bottom split bar up so you have both a Graphics view and a Hierarchy view.

**Step 3** In the Hierarchy view, select the group node Top and set it as the parent.

**Step 4** Open the Create toolbox and click Create DOF. A DOF node will be created as a child of Top.

**Step 5** Select nodes g59 and g60, and drag them on top of the DOF node. When the turret spins around, all the parts sitting on the turret must move with it.

## Position the DOF

**Step 1** Select the DOF node and isolate the view by selecting Select/Isolate or entering `Ctrl+I`.

**Step 2** Rotate the top of the crane until you can see the bottom of the turret.

**Step 3** Turn on the grid, if it is turned off, and set the grid units to 5 or 1.

**Step 4** Open the View panel and click Trackplane from Face. Click the bottom face of the turret to set the tracking plane on the bottom face.

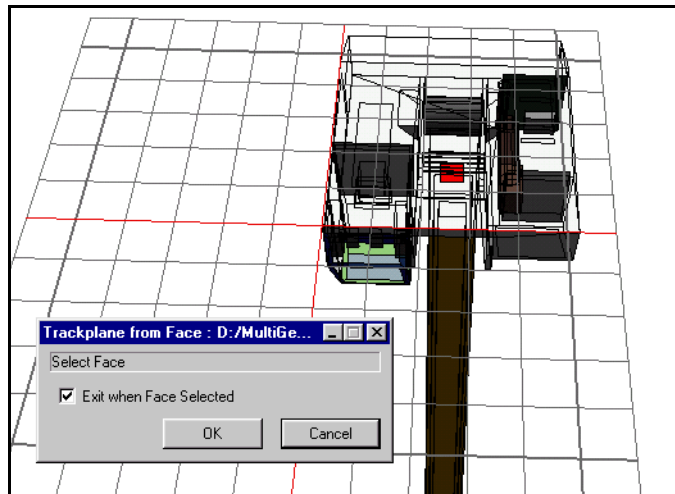

- Step 5** Choose Local-DOF/Position DOF. Set the origin point at the center of the bottom face of the turret and click OK. Close the Isolate view window.

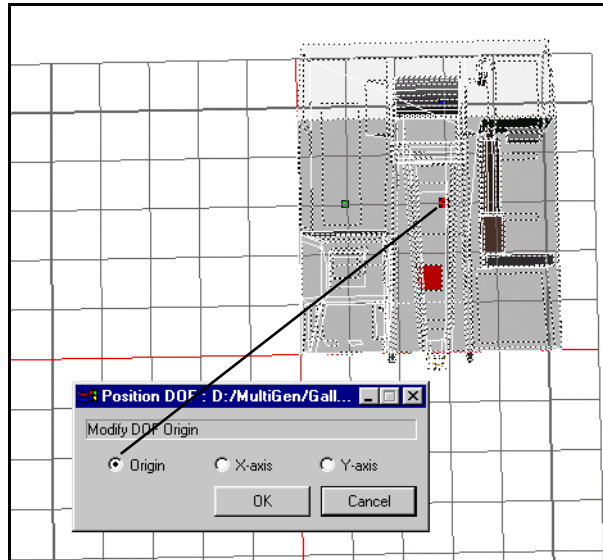

## Set the Limits

- Step 1** With the DOF node still selected, choose Local-DOF/Set DOF Limits. We want the turret to spin around.
- Step 2** Set the rotation to Yaw so the turret will rotate around the Z axis.
- Step 3** The turret will rotate in a full circle, so leave the setting at 0 to 360.
- Step 4** Click the Maximum option and set the maximum value to 360.
- Step 5** Set the Constrain checkbox to constrain the rotation to the limits you have set.



## Exercise the DOF

- Step 1** Click Exercise and drag the exercise pointer to view the rotation. If you have positioned your DOF correctly, the turret should spin around in a circle.

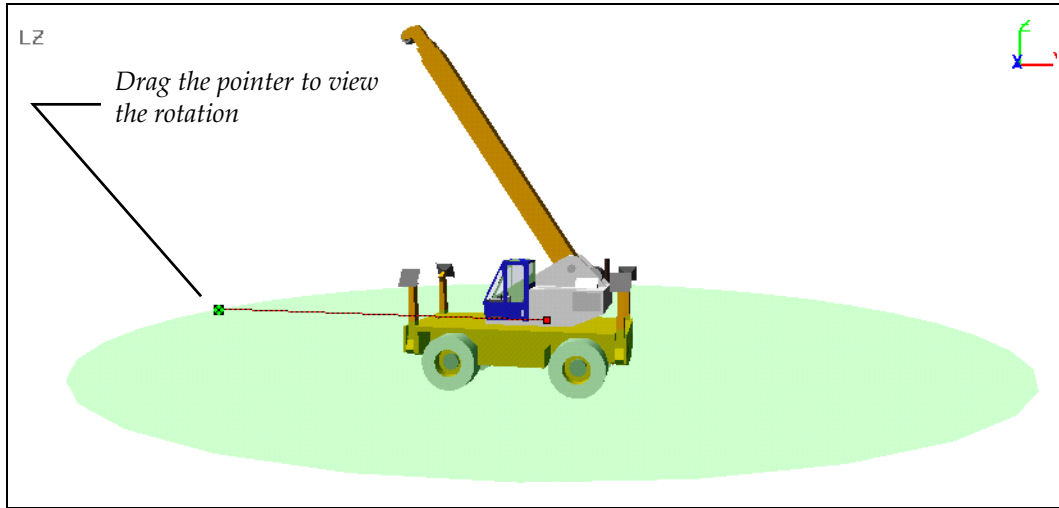

You can animate the limits by setting the Step value to a number other than 0 and then clicking the Animate button.

- Step 2** Click Set Limits and set Step to 2.
- Step 3** Click Animate to automatically rotate the turret assembly.

## Independent Experiment

Try the next part of the exercise yourself. Create a DOF for the boom assembly and set the limits to raise and lower it. When setting the DOF limits, some questions to ask yourself are:

- Which axis will the rotation be moving around? Hint: check the axis in the right hand corner of the Graphics view - the DOF axis is set the same way.
- Will the rotation be 0 to 360 or -180 to 180?
- Will there be a minimum value as well as a maximum value?

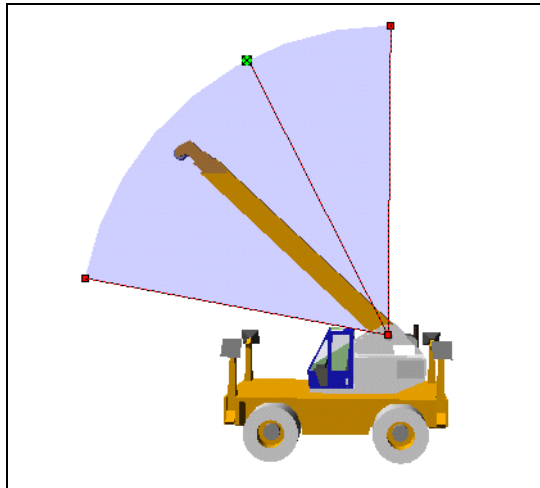

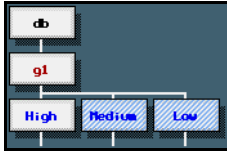

## *Levels of Detail*

### Introduction

Beginners and experts alike share a common problem when developing models for realtime simulations or games — how can I increase the speed and still keep the realism? A fast frame rate is needed to allow users to interact in real time, but complex, detailed models slow the frame rate down too much. One way to increase speed is to use Levels of Detail.

Levels of Detail refers to the “swapping” of complex models with simple models when the distance between the eyepoint and the model is so great that details are no longer visible. By swapping in the simpler model, the realtime system can more quickly render the entire scene and attain a faster frame rate. For example, in a driving simulation, highly-detailed models are only needed for nearby cars. Cars that are farther away can be represented with simpler models, which are swapped in at a predetermined distance.

### Contents

<b>LEVELS OF DETAIL</b>	189	Reducing the Foundation Subtree	196
<b>MODELING GOAL</b>	189	Reducing the Walls Subtree	197
<b>GETTING STARTED</b>	191	Reducing the Roof Subtree	199
Creating the LOD Nodes	191	Patch the Roof	200
Adding Content to the Medium Level of Detail	192	Reducing the Porch Subtree	201
Rename the LOD Subtrees to Match the Original	193	Reducing the Chimney Subtree	202
The 60 Percent Rule	193	Combine Faces	202
<b>ISOLATE THE MEDIUM FARMHOUSE</b>	194	OK, Start Deleting!	203
Working in the Isolate View	195	Make New Faces	204
		How did we do?	204

<b>SIMPLIFYING THE LOW LOD</b>	205
More Chimney Work	206
Reducing the Low Walls	207
Mapping a Texture to the Back Wall	208
The Front Wall	209
Caveat Emptor	209
Attic Windows	210
The Side Walls	210
Final Polygon Tally	210
<b>SWITCHING DISTANCES</b>	211
Setting Switching Distances	211
Using AutoLOD	212
Try It!	212
It's all Wrong!	212
Using More Detail and Less Detail	213
The Big Picture	213



## *Levels of Detail*

### **Modeling Goal**

The goal is to reduce the number of polygons in each level to simplify the farmhouse. The simplest model is used when you are far away. As you approach the farmhouse, increasingly complex models allow you to see more detail — much the same way as the human eye sees.

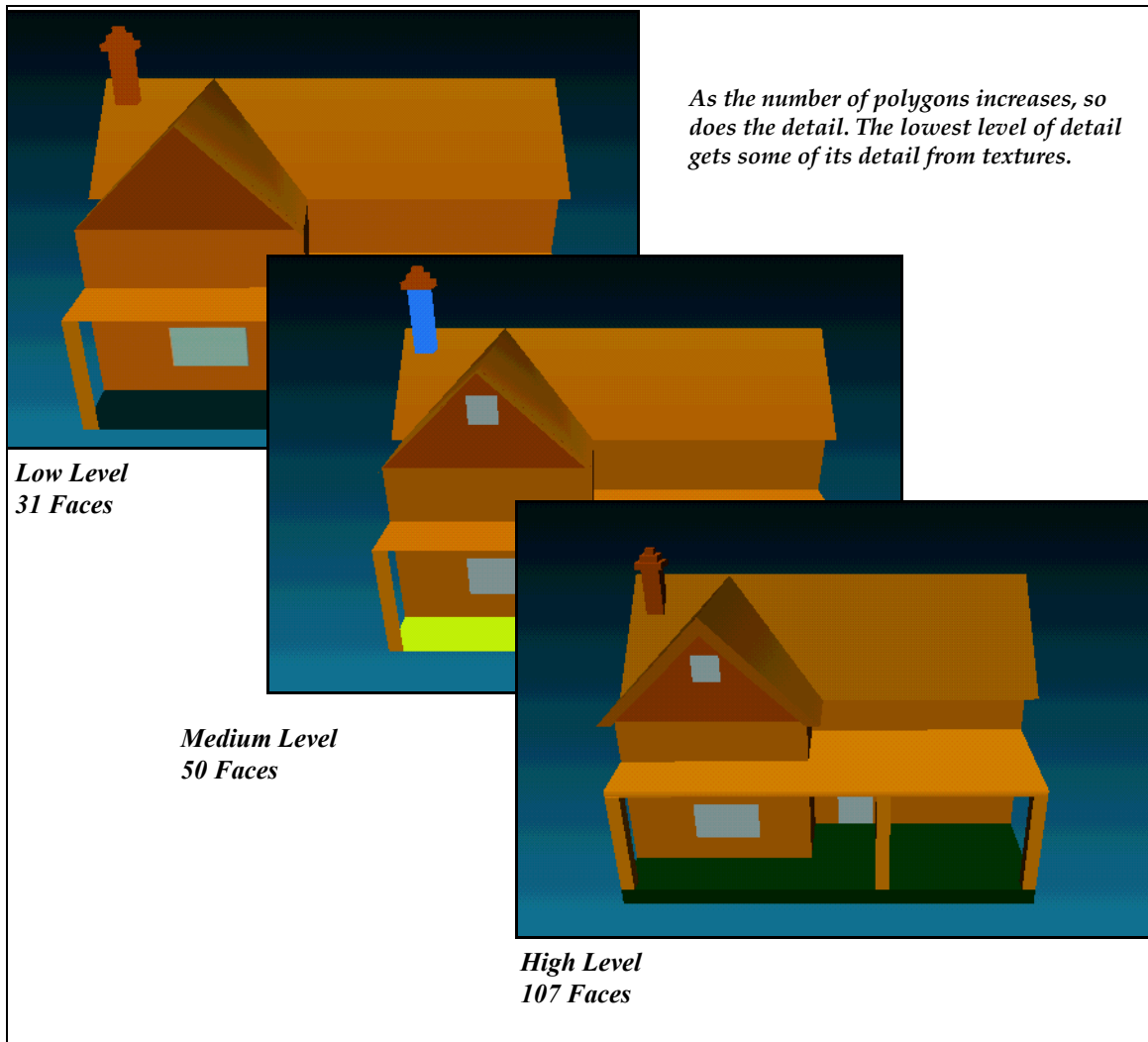

You've already done the hard work of making the complex, highly detailed farmhouse. Now comes the process of simplifying it.

In this exercise you'll take the **farmhouse.flr** file that you created in the *Construct Your First Realtime Model* chapter (or use the **farmhouse.flr** file that comes with MultiGen), and add two levels of detail to it. Although you are adding to the total number of polygons in the file, only one model will be visible at any one time. Since only the visible polygons are rendered, only the visible level of detail impacts the speed of the realtime system.

You are creating three separate farmhouses that all occupy the same position in space. Only one farmhouse is visible at any one time as they are switched based on the distance from the eyepoint. The switching distance is covered later in the chapter after you make the other two farmhouses.

There are at least four ways to reduce polygon count:

*Remove hidden polygons.* This is especially important for interiors of the farmhouse, such as the floor and any interior walls.

*Make the model more 2D rather than 3D.* As the distance to a model increases, it becomes harder to distinguish depth, so 2D versions of a feature is OK. We'll use this technique to simplify the roof of the farmhouse.

*Replace complex shapes with simple outlines.* Complex polygons or multiple polygons can be replaced with simple polygons. We'll use this technique to simplify the chimney.

*Use textures to replace detail.* Many modelers use this technique; make the most complex version of the model first, then take screen shots to make an image file. These images can then be used to make lower levels of detail. For example, when reducing polygons, details can often be preserved by using textures on simple polygons. The side of a house can be one polygon with a texture image of the higher model mapped to it. We'll use this technique for the lowest level of detail model.



## Getting Started

The model as it is now will be the “High” level of detail model — it has the highest polygon count. The other two levels each have a lower polygon count.

## Creating the LOD Nodes

For this exercise, use the `farmhouse.flt` file or the file that you created in Chapter 3.

- Step 1** Close all open files and open `farmhouse.flt`.
- Step 2** In the Hierarchy view, select `g1` as parent.
- Step 3** Select Create LOD from the Create Tools toolbox. A Level of Detail node called `L1` is created under the `g1` node.
- Step 4** Repeat the step above twice more to create an `L2` and `L3` node.
- Step 5** Rename the nodes from `L1`, `L2`, `L3` to *High*, *Medium*, and *Low* (Ctrl+J).

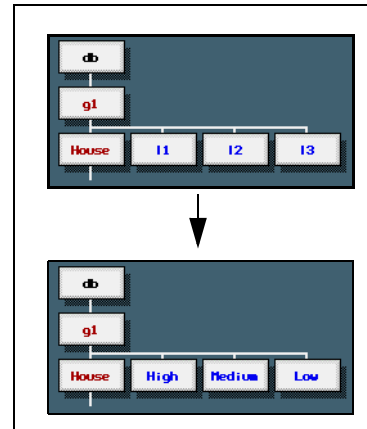

### Adding Content to the Medium Level of Detail

**Step 1** Select the House node and drag it under the High node.

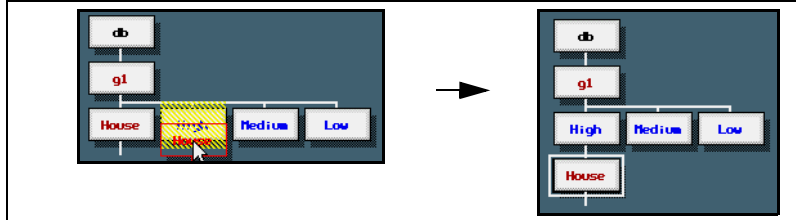

**Step 2** With the House node still selected, choose *Edit/Copy* (Ctrl+C) to copy the House node and its entire subtree.

**Step 3** Alt-click the Medium node to set it as Parent. Choose *Edit/Paste* (Ctrl+V), then click OK in the *Paste Graphics* dialog box.

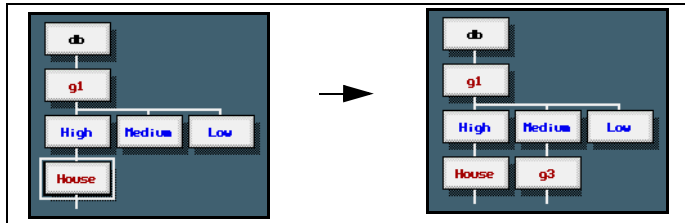

Don't put anything under the Low node yet. After we complete the Medium model, we'll copy this model over to the Low node and then simplify it.



## Rename the LOD Subtrees to Match the Original

One bit of housekeeping first. Rename the Medium node's subtree with similar names to the subtree under the High node. It will be easier to keep track of the nodes later.

### Step 1 Rename the Group node under Medium to MHouse.

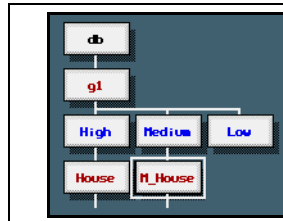

The MHouse node corresponds to the House node level in the hierarchy. You cannot name it exactly the same, because MultiGen does not allow nodes to have identical names.

### Step 2 Expand the MHouse node subtree and rename the nodes to MFoundation, MWalls, MRoof, MPorch, and MChimney. To expand a subtree, select the node and press the middle mouse button.

Rename the nodes in the subtree beneath the Medium node.

Now we can begin simplifying the medium level of detail.

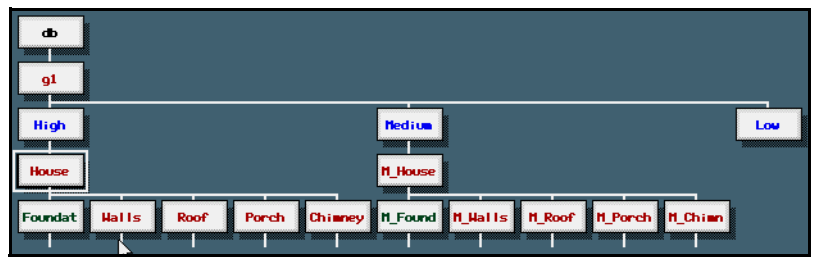

## The 60 Percent Rule

A good rule of thumb is to reduce the number of polygons for each LOD to 60 percent of the original. The original farmhouse had 107 polygons. So, the medium level of detail should have about 60 polygons. To see the statistics for the house, select the House node and choose **Info/Statistics**.

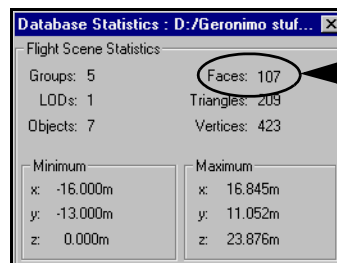

The polygon count for the Medium Level of Detail is the same as the High level now.

Your goal is to reduce the number of polygons by 60 percent.

## Isolate the Medium Farmhouse

All three farmhouses will stay in the same position in the database so that when they are swapped, one model will replace the other. However, to work on a model, you must view only one model at a time. The first step is to isolate the model.

- Step 1** Select the Medium node and choose **Select/Isolate (Ctrl+I)**. A window containing only the Medium farmhouse is opened.
- Step 2** Drag the split bar up to reveal the Hierarchy view. Only the Medium node and its subtree are shown in Isolate view.

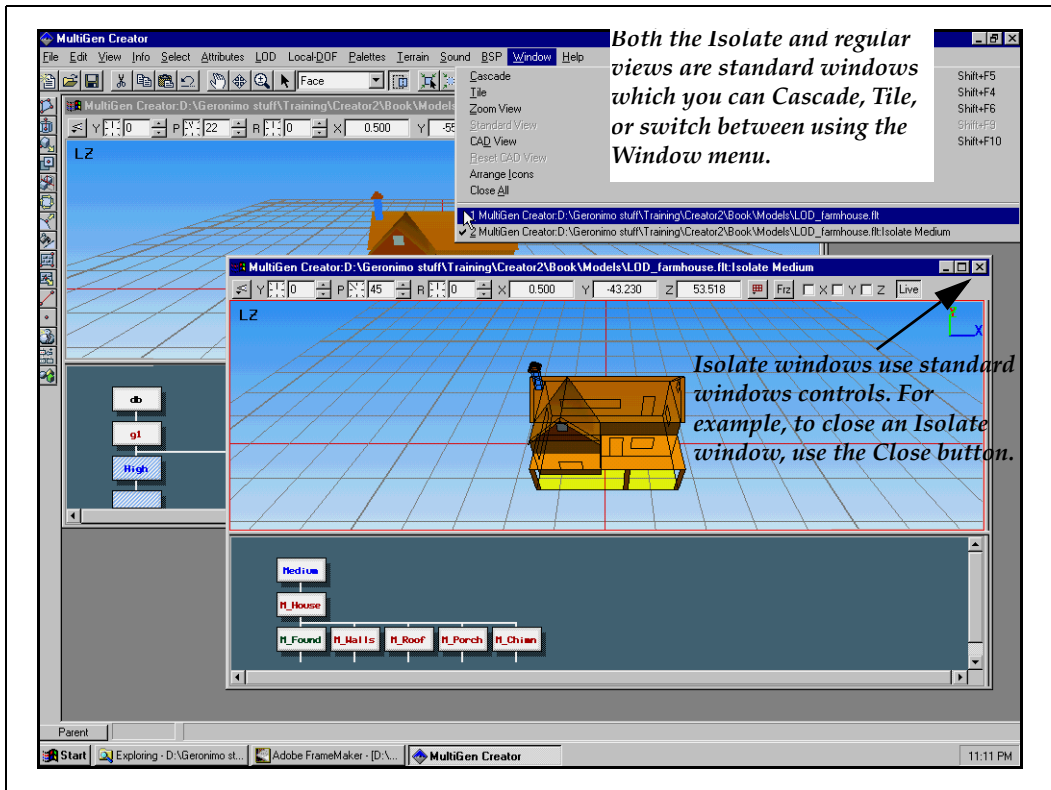

## Working in the Isolate View

When you are working in Isolate view, you can take advantage of the Live feature or turn it off. Here we want it turned off.

When the Live button is selected, the *Isolate* window is automatically updated to show whatever node is selected in the Hierarchy view of the original database.



Try it now. If you have followed the steps above, you have selected the Medium node and isolated it. Then, follow these steps:

- Step 1** Make sure the Live button is selected and then switch back to the original database file by choosing *Window/farmhouse.ftt*.
- Step 2** Select the Foundation node.
- Step 3** Switch back to Isolate view using the Window menu. Do not use *Select/Isolate* again because another window opens.
- Step 4** In the *Isolate* window, only the foundation is shown. For our purposes, it is better to turn the Live button off for now.
- Step 5** Switch back to the original window. Select the Medium node, then switch back to the *Isolate* window and turn off the Live button.

## Reducing the Foundation Subtree

Make sure you have the Medium node selected in the original database, then switch to the *Isolate* window and make sure the Live button is deselected.

**Step 1** Expand the MFoundation subtree.

**Step 2** Select and delete all of the nodes except the node that represents the bottom-most polygon. This is the polygon that corresponds to p79 in the High LOD model. To switch back to the original database, use the Window menu.

**Step 3** Use the Reverse Face tool to make the Foundation visible.



The farmhouse now appears to float above the terrain, because we have made the foundation 2D instead of 3D. To bring the farmhouse back to Earth, we need to select the whole house and translate it downward in the Z direction.

**Step 1** Change into Vertex mode (Shift+V).

**Step 2** Select the MWalls, MRoof, MPorch, and MChimney nodes, but not the MFoundation node.

**Step 3** Freeze the X and Y axis, so the only possible movement is in the Z axis.



**Step 4** Select the Translate tool from the Maneuver Tools toolbox.

*Settle down! Use the Translate tool to bring the house to earth. The middle mouse allows you to select the corner vertex on the foundation.*

*Note that the lighting was changed to make it easier to see details.*

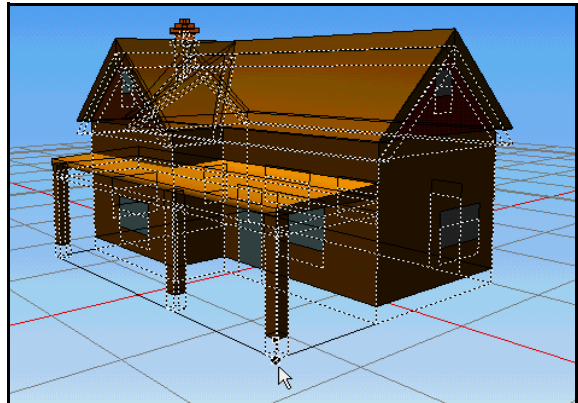

**Step 5** For the From Point, use the middle mouse to select a vertex at the bottom of the corner post on the porch.

**Step 6** For the To Point, use the middle mouse to select the corner of the foundation. Click OK to move the house down.



## Reducing the Walls Subtree

**Step 1** Expand the Walls subtree.

**Step 2** Expand the Object node to see all 11 faces. Delete the faces shown in the illustration. If you delete the wrong face, you'll see through the house. Choose *Edit/Undo* (Ctrl+Z) to undo the deletion.

*Select the entire house and then choose Select/Select Concave Faces to select these two faces and delete them.*

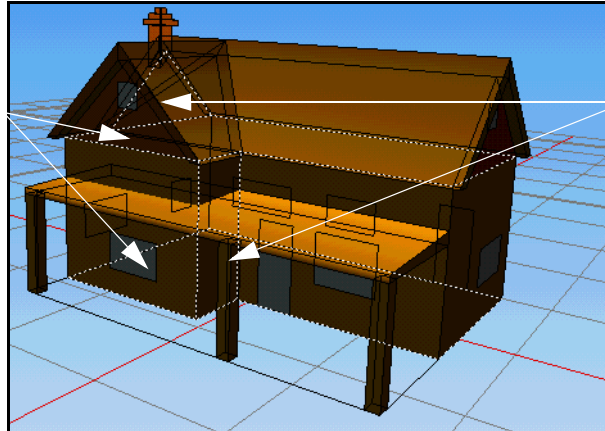

*Keep these faces*

### Combining Windows

Some of the remaining nodes have subfaces that represent windows. From a distance, these polygons are not visible as separate windows. Combine these windows to eliminate extra polygons.

- Step 1** Make sure you are in Vertex mode. Rotate the farmhouse so you are looking at the back. You will combine the two back windows into one.
- Step 2** Freeze the Y and Z axis.
- Step 3** Select the two vertices on the right side of the left-hand window.

*Drag a fence around the right side of the left window to select the vertices.*

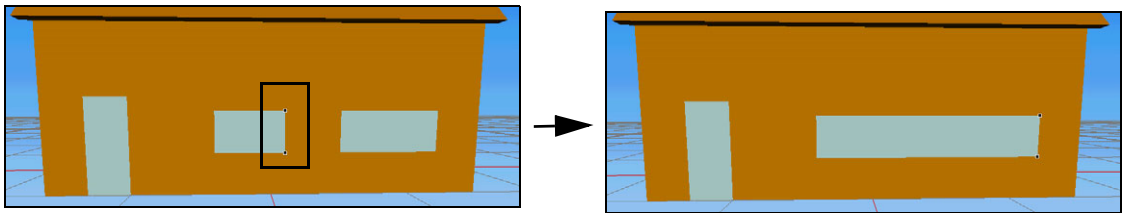

*Tip: It is easier to select the window's vertices if the window node is selected in the Hierarchy view.*



*Middle-click the right side of the right window to set the new width for the left window. Then delete the old right window.*

- Step 4** Select Modify Vertices from the Modify Vertices toolbox. 
- Step 5** Set the vertices to the right side of the right window using the middle mouse button.
- Step 6** In the Hierarchy view, select and delete the old right window.
- Step 7** Repeat this procedure to combine the two windows on the left side of the house (right side from the back of the house). Freeze the X and Z axis for this side.



## Reducing the Roof Subtree

- Step 1** Expand the Roof subtree. Make sure you are in Face mode (Shift+F).
- Step 2** On the long roof of the house, select and delete all of the nodes except the node that represents the bottom-most polygon. This is the polygon that corresponds to p111 in the High LOD model.

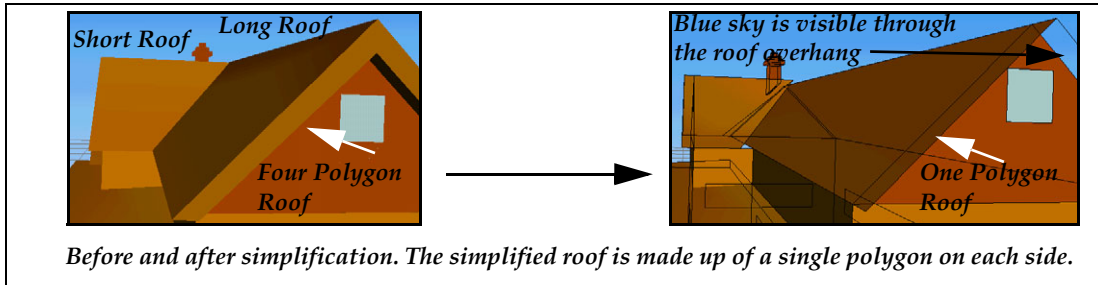

*Don't Panic!* The bottom-most roof polygon appears to be missing. It isn't; you are just looking through it. Use the Reverse Face tool to flip it so it is visible from outside of the house.



- Step 3** Repeat the previous step for the opposite side of the roof. The remaining polygon corresponds to p117 in the High LOD model.
- Step 4** Do the same thing for the short roof. Repeat the entire procedure leaving only two polygons, which correspond to p140 and p 148 in the High LOD model.
- Step 5** To make the overhang of the roof visible from below, as shown in the illustration, make all the roof polygons visible from both sides. Select all four nodes, then open the *Face Attributes* window (Ctrl+=), select the *Drawing* tab and check the *Render Both Sides Visible* checkbox.

### *Polygon Tally.*

You have now reduced the number of polygons for the roof from 18 to four! You should now have only 80 polygons in the model; twenty more to go to reach our goal of 60.

### Patch the Roof

The short roof no longer reaches all the way to the long roof. Set your eyepoints to (85, 0, 0). Take a moment to patch the roof.

*There are several ways to fix the roof; translate and scale the roof cross-section, plant its left two vertices to a tracking plane aligned with the roof, or modify the vertices. The modify vertices method is shown here.*

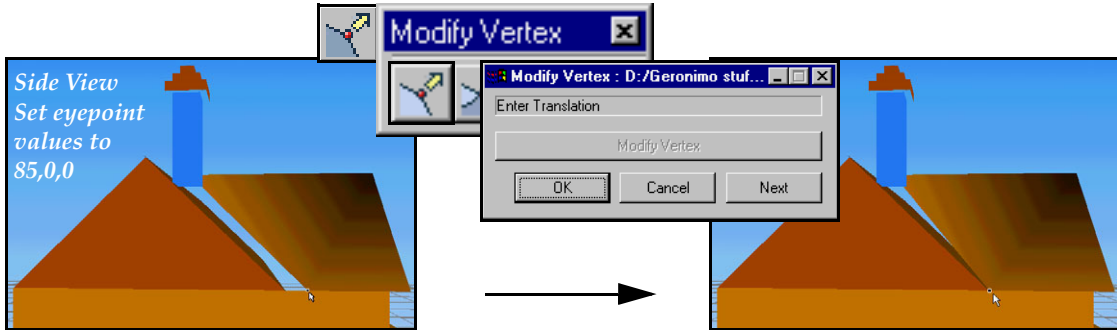

*Set the eyepoint to (85, 0, 0) and in the Vertex mode, middle click on the bottom corner of the short roof. Move the vertex to the long roof with the Modify Vertex tool.*

*The chimney is in the way. It is easier to select the top vertex from the opposite side. Move your eyepoint to (-85, 0, 0), then middle click to select the top vertex point on the short roof and use the left mouse button to set the vertex to a point on the long roof line. Finally, repeat the procedure on the bottom of the roof.*

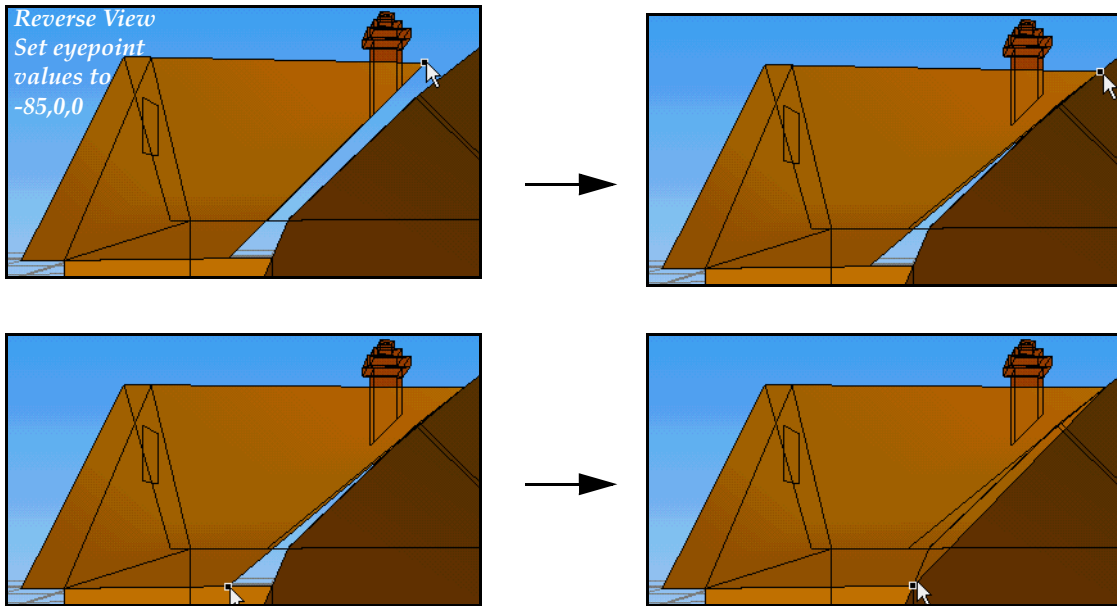

## Reducing the Porch Subtree

Each of the three posts and the roof of the porch can be represented with a single polygon.

- Step 1** Expand the Porch subtree.
- Step 2** Expand each object to show the Face nodes.
- Step 3** Delete all the Face nodes for each post except the one facing toward the front of the house.
- Step 4** Delete all the nodes for the porch roof except the bottom-most polygon.

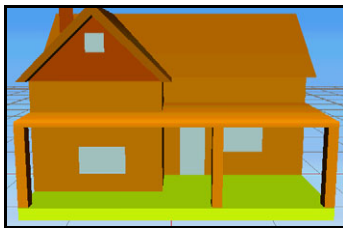

*Porch before and after. Twenty-one polygons are reduced to four.*



**Tip:** The posts will be visible only from the front of the house. Make both sides visible so they can be seen from other angles. Double-click each post face to display its *Face Attributes* window, then select the Drawing tab and check the Render Both Sides Visible checkbox. Do the same procedures for the porch roof polygon, so it can be seen from underneath.

## Reducing the Chimney Subtree

The chimney has 36 faces — an obvious target for polygon reduction. We can combine faces, replace smaller faces of the top of the chimney with simple square faces as well as eliminate other hidden faces to end up with a total of only 23 faces to represent the chimney!

- Step 1** Select the Chimney subtree and expand it.
- Step 2** Isolate the chimney by selecting the MChimney node and choosing *Select/Isolate* (Ctrl+I).
- Step 3** Make the Object node below the MChimney node the Parent.

## Combine Faces

The top polygon on the chimney is actually made up of four triangular polygons. Combining these four into one polygon is an easy way to reduce the polygon count.

- Step 1** Make sure you are in Face mode. Select all four polygons.
- Step 2** Make sure the vertices are properly edge-matched by clicking the *Modify Vertex/Match Vertices* tool.
- Step 3** Select the Combine Faces tool from the Modify Face toolbox to create one face from the four.

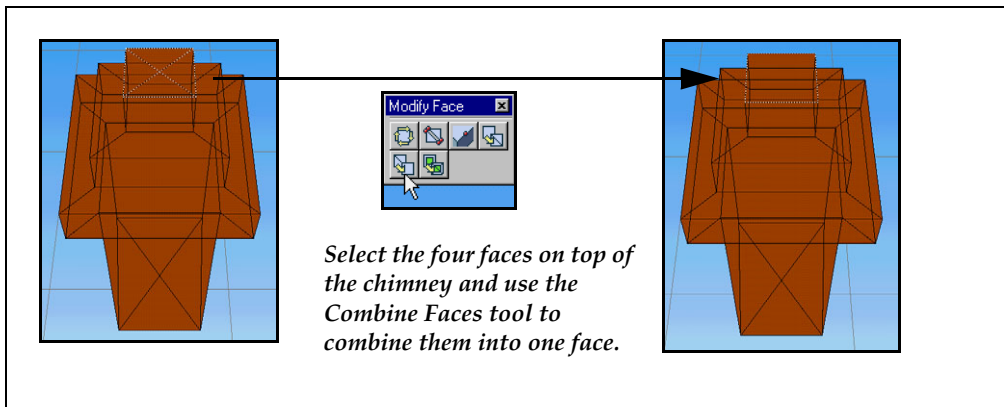

**OK, Start Deleting!**

Delete any hidden polygons, including the four polygons underneath and the eight polygons on the top as shown in the illustration.

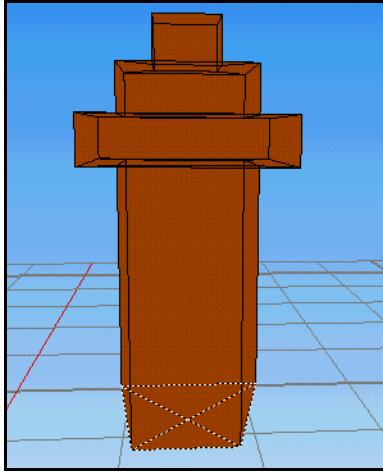

↑  
*Delete the four polygons on the bottom*

*Delete the eight polygons on the top*

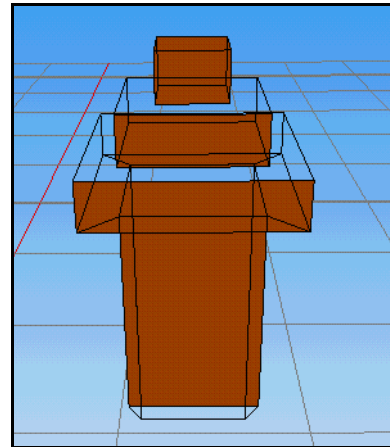

## Make New Faces

- Step 1** To make it easier to see the new polygons, change the primary color to white. Later, when you are done deleting the old polygons on the chimney, you can change the color of the new polygons to red.
- Step 2** Alt-click the Object node under MChimney to make it the Parent.
- Step 3** Position the eyepoint so you are looking directly downward at the chimney. Use the Polygon tool to make two new polygons, as shown in the illustration. Use the middle mouse button to snap the points to the corner vertices.

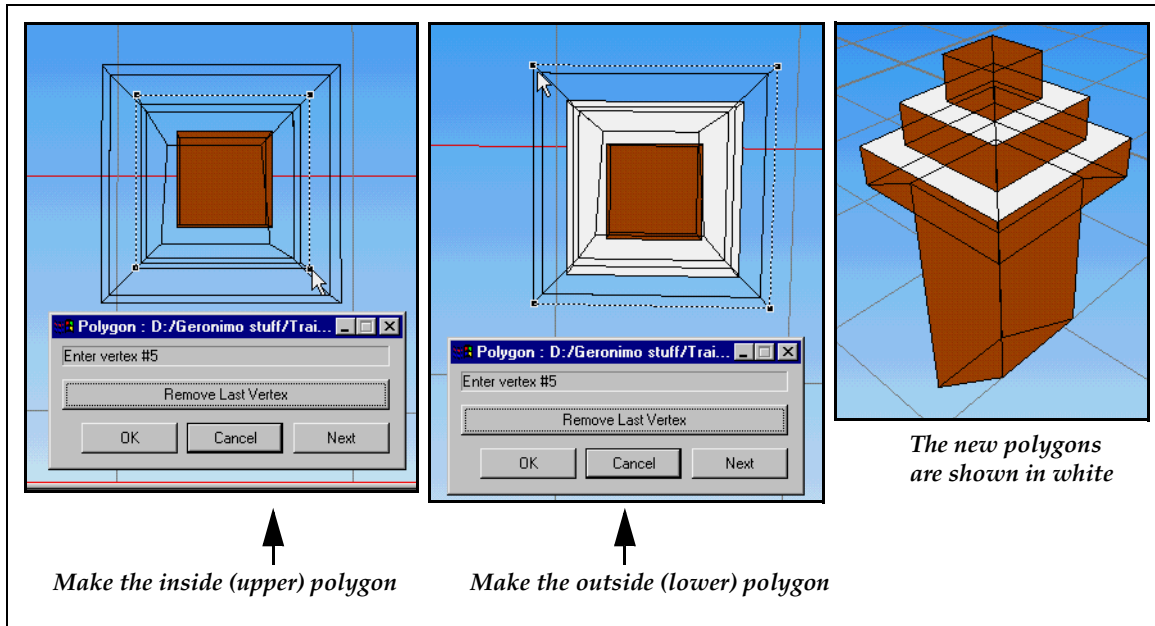

- Step 4** Change the new polygons to the chimney red color. Sample the red in one of the original polygons with the Get Color From Face tool in the Properties toolbox. Apply the color to the new polygons with the Insert Color tool.

## How did we do?

The Medium Level of Detail is done! Check the total number of polygons for the Medium model. You should have a total of 50 faces. Remember we were trying for 60 faces for the Medium model. You are an overachiever! For the Low model, we will reduce the polygon count to 60 percent of the Medium model — or about 30 faces total.



## Simplifying the Low LOD

First, we'll copy all the nodes under the Medium subtree, and paste them under the Low node. Then, we'll continue to reduce the number of polygons from 50 faces to 31 faces.



- Step 1** Select the MHouse node and choose *Edit/Copy* (Ctrl+C).
- Step 2** Select the Low node and make it the Parent. Choose *Edit/Paste* (Ctrl+V). Click OK.
- Step 3** Rename the nodes under the Low node to match the nodes under the High and Medium nodes.

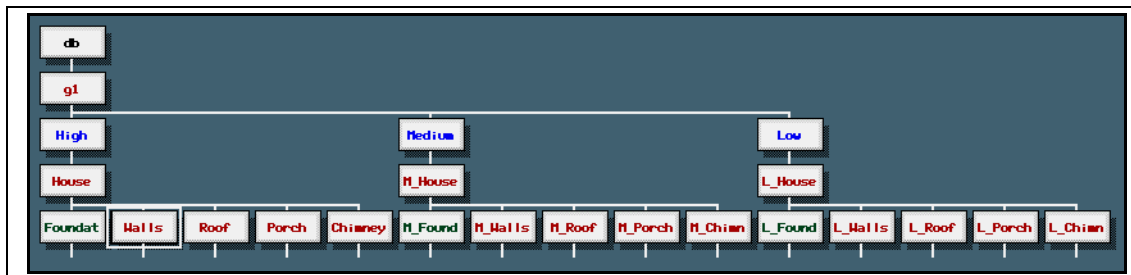

### More Chimney Work

As long as we've been working on the chimney, let's continue to simplify it.

**Step 1** Select the Low node and isolate it.

**Step 2** Continue deleting polygons until your chimney looks like this:

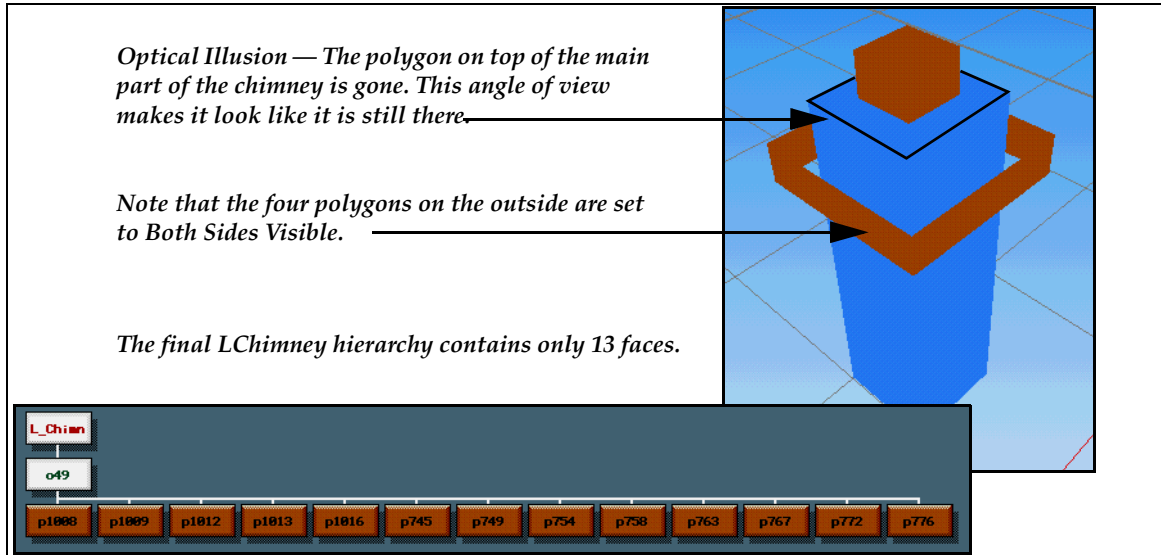

**Step 3** Improve the visibility of the strip of polygons around the chimney. Select one of the four polygons, as shown in the illustration, and make both sides visible. In the *Face Attributes* window, select the *Drawing* tab and check the *Render Both Sides Visible* checkbox.

**Step 4** Repeat the above step for the other three faces.



## Reducing the Low Walls

Now, you only need to simplify the walls. The chimney is done and the roof and porch have only four polygons each, so they can't be reduced. The foundation is a single polygon, but the Walls subtree still has 18 faces. By using textures to simulate windows, we can reduce the walls to nine faces.

- Step 1** Set the eyepoint to (180, 0, 0) to view the back wall.
- Step 2** In the Hierarchy view, expand the node for the back wall to show the window subfaces.
- Step 3** In Face mode, select the back wall.
- Step 4** Delete the door and window.

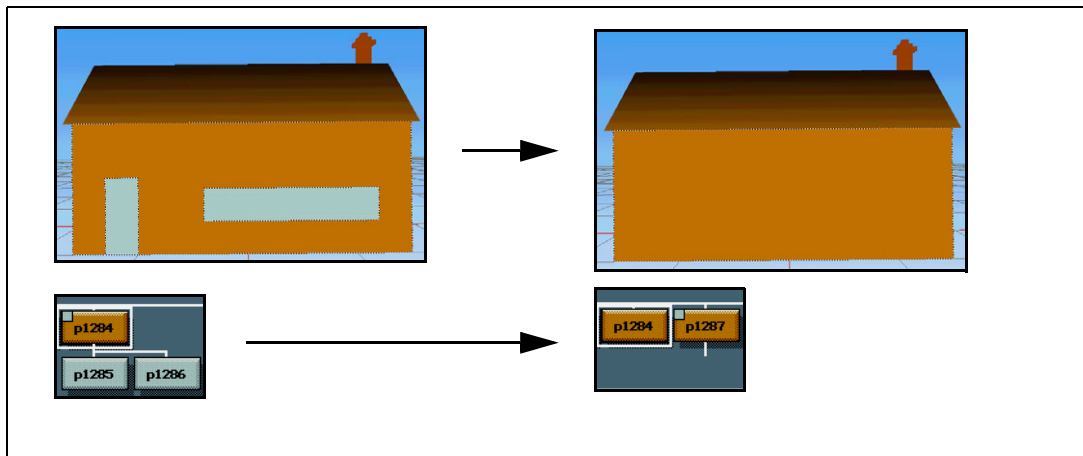

- Step 5** Now we will remove the color from the face. Select the back wall in Face mode and open the *Attribute* window. Click the Colors tab and type 127 in the Primary Color Index field to set the polygon color to white.

## Mapping a Texture to the Back Wall

The texture you are about to map to the back wall is just a screen capture of the back wall of the farmhouse saved in the JPEG (.jpg) format. The texture was created with a screen-capture utility program. Since MultiGen imports a wide variety of image file formats, many screen-capture programs can be used to make this texture. Import the texture and apply it to the back wall.

- Step 1** Click **Current Texture** in the **Toolbar**. In the **Texture palette**, choose **File/Read Pattern**.
- Step 2** In the **Read New Pattern** dialog box, click **OK**.
- Step 3** Open the image, **wall\_back\_texture.jpg** in the `\Program Files\Multigen-Paradigm\resources\tutorials\creator\DesktopTutor\Textures (Windows)` or `/usr/local/MultiGen-Paradigm/resources/tutorials/creator/DesktopTutor/Textures (IRIX)` directory. This is a screen capture of the back of the house. Choose **File/Close** in the **Texture Palette** window to close the Texture palette.
- Step 4** Turn on textures (press the T key). In the **Graphics view**, select the **Put Texture** tool from the **Map Texture** toolbox to display the **Put Texture** dialog box. 
- Step 5** In the **Graphics view**, place the **Origin** point on the lower left-hand corner of the polygon.
- Step 6** Place the **Alignment** point on the lower right-hand corner of the polygon and the **Shear** point on the upper right-hand corner. Click **OK**.

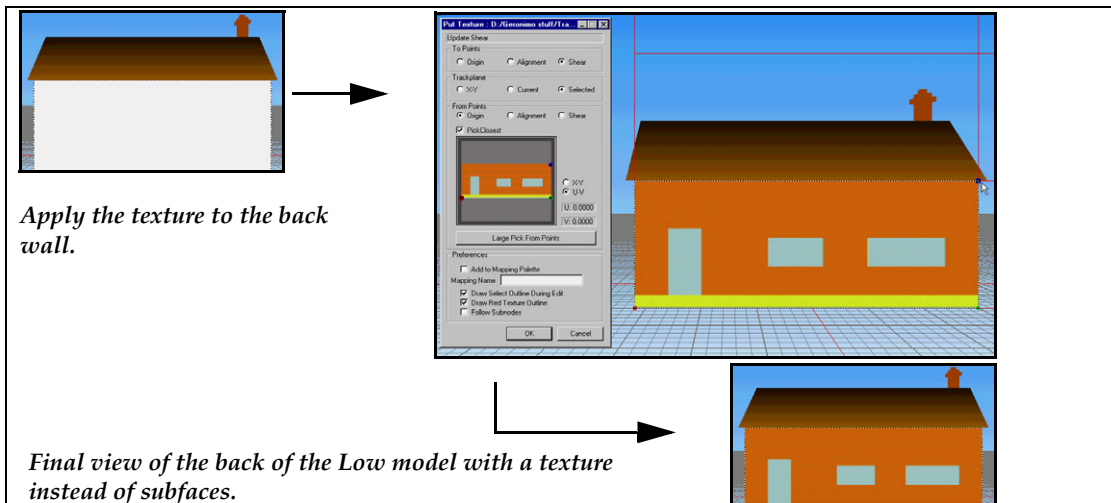

## The Front Wall

Repeat the texture-mapping procedure to map two textures to the front wall.

- Map *wall\_front\_texture01.jpg* to the left front side of the house.
- Map *wall\_front\_texture02.jpg* to the right front side of the house.

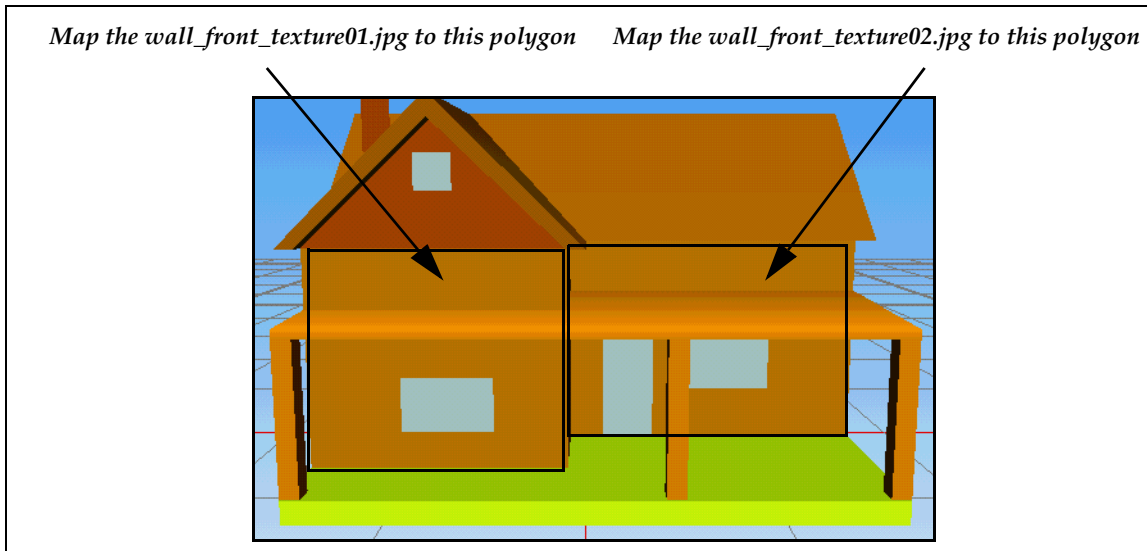

## Caveat Emptor

Trading textures for polygons is not always the best route to take for performance. Depending on the realtime system, textures may slow performance more than the additional polygons would. Test your models in the realtime system.

## Attic Windows

The upper windows of the house present a different dilemma because of the two triangular-shaped polygons with windows, as shown in the illustration.

Textures must be rectangular to map them to a polygon. The polygons here are triangular so the only way to add window textures to these triangles is to clamp a rectangular window texture to the triangular polygon. Since this is not the focus of this tutorial, let's remove the windows. The windows are not noticeable features from the distances at which the Low model will be used.

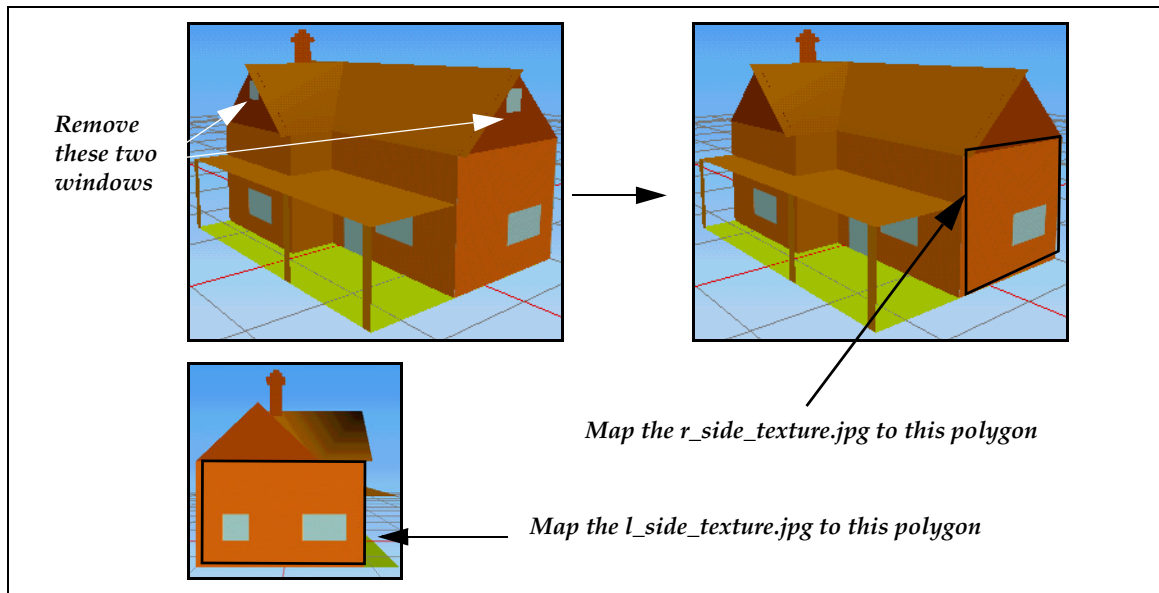

## The Side Walls

Remove the subfaces from the side wall polygons and map textures to them.

- **Map *wall\_r\_side\_texture.jpg* to the right side of the house.**
- **Map *wall\_l\_side\_texture.jpg* to the left side of the house.**

The Low level of detail model is done. Save your file.

## Final Polygon Tally

You have now reduced the number of polygons for the Low model to 31 faces. Remember the High model is 107 polygons and the Medium model is 50 polygons.



## Switching Distances

Now that you have three models, you need to determine their switching distance — the distance where one level of detail model is swapped with another. Switching distances are measured from the eyepoint to the center point of the model. As the eyepoint is moved toward or away from the model, the switching distance for each LOD node is evaluated to determine whether the distance falls within its parameters. If the distance falls within its parameters, the model is drawn (rendered).

The best way to determine switching distance is simply to try viewing models at varying distances from your eyepoint. When you cannot discern the difference between two models at a certain distance, enter that value in the *LOD Attributes* window. However, for now, use the values shown below.

### Setting Switching Distances

LOD switching distances are set in the *LOD Attributes* window.

- Step 1** Open the *LOD Attributes* window for the High farmhouse model by selecting the node and choosing *Attributes/Modify Attributes* (Ctrl+=).
- Step 2** Type 50 in the Switch In field. Type 0 (zero) in the Switch Out field.
- Step 3** Without closing the *LOD Attributes* window, click the Medium node. The *LOD Attributes* window now shows the attributes for the Medium farmhouse model.
- Step 4** Type 200 in the Switch In field. Type 50 in the Switch Out field. The Medium model will now switch in at 50 feet, just as the High model is switching out.
- Step 5** Without closing the *LOD Attributes* window, click the Low node. The *LOD Attributes* window now shows the attributes for the Low farmhouse model.

**Step 6** Type 200 in the Switch Out field. Leave the Switch In field set to 10000000. The Low model will now switch in at 200 feet, just as the Medium model is switching out.

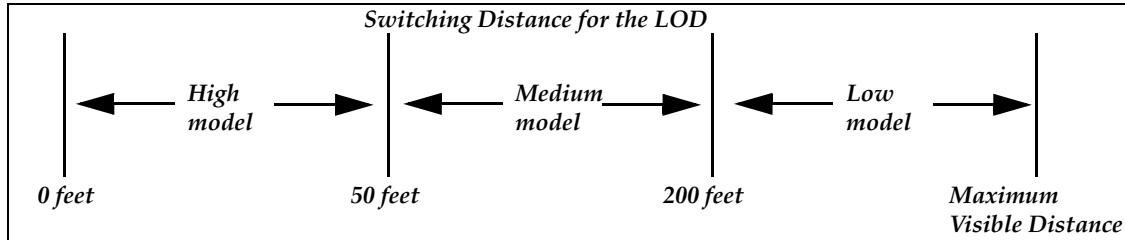

### Using AutoLOD

AutoLOD automates switching distance. By choosing *LOD/AutoLOD*, the switch will occur automatically when the eyepoint is moved toward or away from the model.

### Try It!

Choose *LOD/AutoLOD*. Set the eyepoint close to the farmhouse and slowly move it away to see how the models are switched. If you watch the left side of the house (where the two windows were combined into one window), it is obvious when the models are switched from High to Medium.

When you get far enough away, the Low model is switched in. Again, you'll see the transition by watching the side window change back into two windows (the Low model has a texture applied that has two windows on it).

### It's all Wrong!

The point of using LOD models is to make invisible transitions to different Levels of Detail. We've set the distances so you can easily see when one model is switched to the other, but it's all wrong. The switching distances are set too close to the eyepoint.

Try increasing the distances at which the models are switched until the swapping is unnoticeable.



## **Using More Detail and Less Detail**

Instead of using AutoLOD and moving the eyepoint to switch between LODs, you can switch between the lowest Level of Detail and the highest Level of Detail by choosing *LOD/More Detail* (Ctrl+M) and *LOD/Less Detail* (Ctrl+L).

To switch between the lowest Level of Detail and the highest, choose *LOD/Most Detail* (Ctrl+Shift+M) or *LOD/Least Detail* (Ctrl+Shift+L). In the Hierarchy view, nodes that are not being displayed are shaded blue.

---

### **Note**

**AutoLOD must be turned off for More Detail, Less Detail, Most Detail, and Least Detail to work.**

---

## **The Big Picture**

Remember, we have been creating Levels of Details for only one model. When you have several models with multiple LODs, set the switching distance appropriately, so the realtime program does not have to swap LODs for more than one model at a time. A “spike” of computational activity can slow performance while swapping occurs.



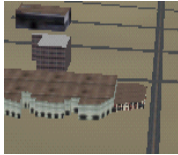

## *Generating Batch Terrain With Features*

### Introduction

You can convert regularly gridded terrain data into polygonal databases, import feature data, and build roads and instrument panels with MultiGen Creator Pro options. Using the MultiGen Creator TerrainPro option and batch processing, you can process terrain data as well as add culture features to the terrain at the same time to generate a real-time OpenFlight terrain model. This section guides you through the tasks to create a batch terrain with projected features.

<b>CREATING TERRAIN USING BATCH PROCESSING</b>			
Batch Processing	216	Apply Terrain Textures to Elevations	231
Creating Projects	217	Enter Levels of Detail Parameters	234
Import Terrain Data	218	<b>SETTING UP FEATURES</b>	234
View the Gaming Area	219	Load Feature Data to Project	235
<b>SET UP GENERAL INFORMATION</b>	221	Load Feature Preferences	237
Load Palettes	221	Load Rules and Actions	240
Check the Texture Directory Path	223	Set up Substitution Models	244
View Texture Options	224	Select Area Blocks to Generate	247
<b>SETTING UP TERRAIN</b>	225	<b>GENERATING THE TERRAIN</b>	250
Set Map Projections	225	Open the Master File	252
Set Triangle Conversion Preferences	226	View the Low Resolution City	253
Set Batch Area Block Preferences	228	View the High Resolution City	255
		Admire Your Work!	255

## Creating Terrain Using Batch Processing

### Modeling Goal

This tutorial will show you how to create an OpenFlight database that includes terrain and culture features, such as roads and buildings, using batch processing. You will import and process an already converted DED file of a one degree area of the city of Palo Alto using the Polymesh conversion algorithm, load files such as palettes and preferences, save the settings in a terrain project file, and generate terrain with projected library substitution models in a single batch process.

### Getting Started

#### What is Terrain?

In general, a terrain database is a collection of polygons that closely represent the land surface on a part of the globe. The terrain data that is used to create the database consists of cells with elevation "post" values that describe terrain surface contours. In each cell, Y (latitude) has approximately 1201 posts. Due to longitudinal convergence, the number of posts in X (longitude) varies according to latitude in order to maintain a consistent post spacing. MultiGen Creator converts these posts into polygon vertices in a terrain database.

#### Batch Processing

The Palo Alto project and other simulation databases are divided into "area blocks" for efficient culling and ordered processing purposes. *Culling* is the process of ignoring areas of a database that are outside the field of view so that those areas are not drawn, and drawing performance is optimized.

An *area block* is a geographical partition of the DED file (the terrain post file). The Batch option integrates terrain skin and culture features into a well-structured database of separable and edge-matched area blocks. Culture features are automatically sliced where they overlap area block boundaries to maintain precise separability.

Each area block is processed as a separate OpenFlight file, and a master file is created which contains external references to each of the area block databases.



## **Creating Projects**

It is always a good idea to organize your data into projects, so that all your source data and output files are organized together. The Project panel lets you specify all the terrain window settings, preferences and palettes associated with a terrain project and save them into a project file (\*.prj). Whenever you load a project file, Creator automatically loads the supporting preferences, settings and palettes.

In this tutorial, you will complete these tasks for batch processing:

- **Import the converted terrain post file.**
- **Load preference files and palettes.**
- **Select area blocks in the terrain post file to be processed. Each area block is processed into a separate file and written to a specified directory. Each file created contains its own geometry, LODs, and properties defined by the terrain preferences.**
- **Create a terrain project file that contains your terrain generation settings, preference files and palettes.**
- **Open the master file in Creator, which contains external references to each of the files to view your terrain with projected features.**

### Import Terrain Data

The first step in creating a terrain database is to import the Digital Elevation Data (DED) file into MultiGen Creator. The terrain data that you will import for the Palo Alto project was previously converted into a DED post format for importing and correlation. The *peninsula.ded* file represents a one degree area of northern California that contains both natural and man-made features.

To import terrain data:

- Step 1** Choose Terrain/New Project to display the *Open Terrain File* dialog box.
- Step 2** Locate the *peninsula.ded* file in the *\Program Files\Multigen-Paradigm\resources\tutorials\creator\DesktopTutor\Batch\_Tutorial\Terrain* directory (Windows) or the */usr/local/MultiGen-Paradigm/resources/tutorials/creator/DesktopTutor/ Batch\_Tutorial/Terrain* directory (IRIX), and click Open. The *Terrain* window appears and displays the terrain that is in the DED file.

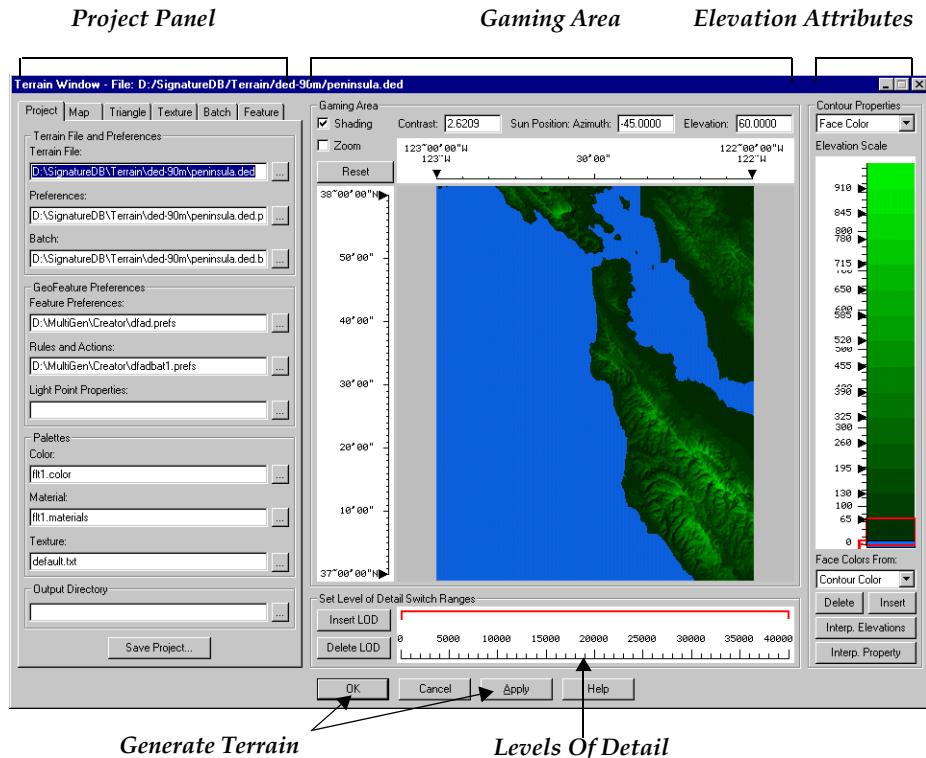

---

**Note**

**Terrain post elevation data must be in the Creator DED format. Creator includes several utilities for converting standard file formats, such as the United States Geological Survey (USGS) Digital Elevation Model (DEM) format as well as the United States National Imagery and Mapping Agency (NIMA) Digital Terrain Elevation Data (DTED) format, to DED format with the file extension .ded.**

---

**View the Gaming Area**

The Gaming Area is where you select the terrain area or areas you want to process. The terrain image takes its colors from the Face Colors in the Contour palette. Each range of elevations is assigned a different shade. Any changes made to the Face Color settings is immediately updated in the Gaming Area.

The terrain image in the Gaming Area can be viewed as a flat-shaded image, or as a shaded relief. You can adjust the contrast, direction, and height of the “sun” as it shines on the terrain, and then save the image as a geospecific texture and apply it to your terrain.

# 11 Generating Batch Terrain With Features

## Creating Terrain Using Batch Processing

Try changing the colors, elevation ranges, and the sun position.

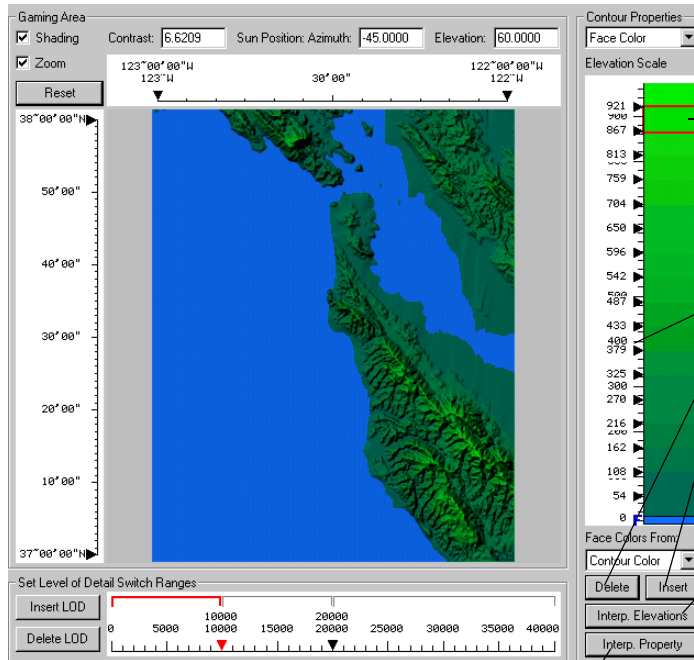

Double-click a color band to open the Color palette window

Drag a pointer to adjust the size of an elevation range, or click Insert or Delete to insert or delete a contour

Resizes the range of contours evenly

When use with color, fills each contour with a gradient of the top and bottom color

**Step 1** Double-click a color band to open the Color palette window.

**Step 2** Choose a new color. The color band will update with the new color.

**Deselect the Shading checkbox and note how the terrain appears in the Gaming Area.**

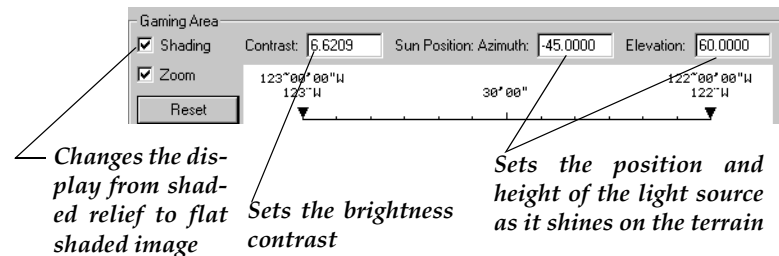

Changes the display from shaded relief to flat shaded image

Sets the brightness contrast

Sets the position and height of the light source as it shines on the terrain



**Step 3** Reselect the Shading checkbox and change the Contrast, Azimuth, and Elevation values, and note the changes in the Gaming Area.

---

**Note**

These adjustments will have no effect on the database that is created; only on the image that is written out.

---

## Set up General Information

### Load Palettes

Customized palettes of colors, materials, and textures can be loaded in the Project panel and applied to your terrain and culture features.

In the following exercise, you will use default color and material palettes, but will load a pre-configured texture palette into the Project panel in the *Terrain* window and then indicate where the new terrain files should be stored.

**Step 1** Select the Project tab to display the Project panel.

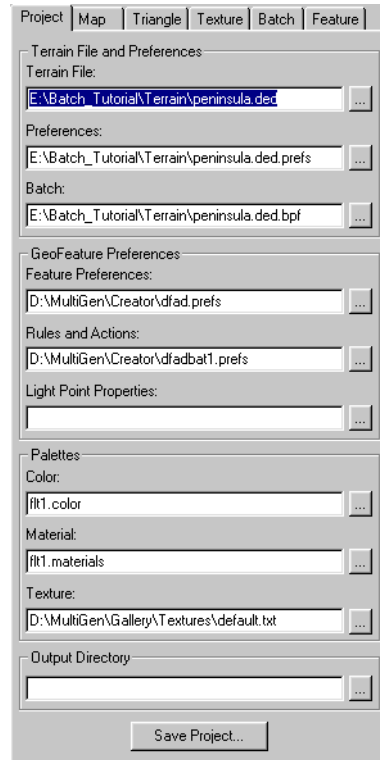

- Step 2** In the Palettes section, click the button next to the Texture field to open the Choose Texture Palette File dialog box.
- Step 3** Locate the *palo\_alto1.txt* file in the *\Program Files\Multigen-Paradigm\resources\tutorials\creator\DesktopTutor\Batch\_Tutorial\Textures (Windows)* or the *usr/local/MultiGen-Paradigm/resources/tutorials/creator/DesktopTutor\Batch\_Tutorial\Textures (IRIX)* directory, and click Open.
- Step 4** Click the button next to the Output Directory field and use the browser to choose the directory to place the generated terrain files. For this example, set the output directory to the Batch Tutorial directory.



## **Check the Texture Directory Path**

You may have installed the files for this tutorial on a different drive or in a different directory. If so, Creator will not be able to find the textures in the directory path specified in the Texture palette file you loaded in Step 3 of the previous exercise. The Current Texture button in the application window will display a question mark (?), indicating that no textures were loaded. To change the path, follow these steps:

- Step 1** Drag the Terrain window down so that you can see the toolbar in the application window.
- Step 2** Click the Current Texture button to open the Texture palette.
- Step 3** Choose Info/List Textures. The List Textures window lists every texture in the Texture palette. By default, they are listed in descending order by their pattern numbers.
- Step 4** Click Change Selected Path to open a browser, choose the correct path and directory for the texture files, and then click OK.
- Step 5** When the listed textures update with the correct path, click Close to close the List Textures window.

## View Texture Options

The Texture panel contains options for using Geospecific textures and Indirect textures. A Geospecific texture contains geographical attribute information, including latitude and longitude, that indicates where the texture pattern is mapped to the terrain. An Indirect texture contains a bitmapped image file that defines specific colors, textures, and materials as well as an ASCII file that keys each color in the image to a specific group of properties.

You can also write out the displayed contents of the Gaming Area to a geospecific texture file that you can apply to your terrain.

To view the Texture panel:

### Step 1 Select the Texture tab to display the Texture panel.

*Specifies that the texture has longitude and latitude coordinates associated with it*

*Slices faces in the database along the boundaries of the geospecific texture*

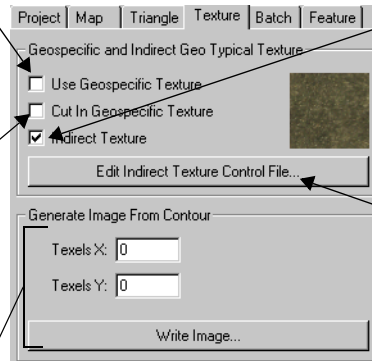

*Maps a bit-mapped image file to specific areas of the terrain*

*Specifies the texture, color, and material properties of the terrain using a bit-mapped image and an ASCII file*

*Saves the displayed contents of the Gaming Area as a geospecific texture - the Texels X and Texels Y values determine the texture's size*

### Step 2 Check the *Indirect Texture* check box to enable the *Edit Indirect Texture Control File* button. Clicking this button opens a text editor where you can create a file that maps each color in the image file to texture and material properties for each LOD of your terrain.

**Deselect the Indirect Texture checkbox.**



## Generating Batch Terrain With Features

### *Creating Terrain Using Batch Processing*

- Step 3** Click **Write Image** to open the *Write Contour Image to File* dialog box. By specifying the size of the texture file (Texels X and Texels Y) and clicking this button, you can save the Gaming Area contents as a geospecific texture and apply it to your terrain.
- Step 4** Click **Cancel** to cancel the operation.

## Setting up Terrain

### Set Map Projections

Map projections convert gridded terrain posts, or latitude/longitude coordinates, into database coordinates in 3D space. The mapping of latitude/longitude coordinates to corresponding locations in  $x, y, z$  3D space is complicated because of the irregular shape of the earth, which is an ellipsoid, and the surface of the terrain that you want generated, either flat or curved.

For the Palo Alto project, select the Flat Earth projection. A Flat Earth projection uses latitude at the origin to derive a single convergence factor for adjusting every  $x$  value, which results in a rectangular database. All units in this project are in meters, and the area is already defined in latitude/longitude coordinates.

To set map projections:

- Step 1** Select the **Map** tab to display the Map panel.

*Flat Earth map projection*

The image shows a software dialog box with several tabs: Project, Map, Triangle, Texture, Batch, and Feature. The 'Map' tab is active. The dialog is divided into sections: 'Database Units' with a dropdown set to 'Meters'; 'Database Origin' with 'Latitude' set to '37°00'00\"N' and 'Longitude' set to '123°00'00\"W'; 'Map Projection' with 'Map Projection' set to 'Flat Earth' and 'Earth Ellipsoid Model' set to 'WGS84'; and 'Lambert Latitude Lines' with 'Northern Latitude' set to '45°00'00\"N' and 'Southern Latitude' set to '33°00'00\"N'. At the bottom, there is a button labeled 'Write Current Selection to Post File...'. An arrow points from the text 'Flat Earth map projection' to the 'Flat Earth' dropdown menu.

- Step 2** In the Map Projection section, ensure that *Flat Earth* appears in the Map Projection field.



**Set Triangle  
Conversion  
Preferences**

MultiGen Creator uses triangle conversion algorithms (terrain algorithms) and preferences to create vertices in polygons from posts in the terrain data as well as organize the polygons into a hierarchical structure. The triangle preferences that you set determine the posts that are used and the posts that are ignored.

You can select one of these triangle conversion algorithms to meet your simulation needs:

- ***Polymesh* creates a terrain database consisting of a uniform, rectilinear grid of triangles.**

The **Irregular Mesh** option uses a non-rectilinear polygon and adjusts the midpoint of each polygon to a position of maximum deviation. This results in irregular triangles which more accurately describe the terrain.

- ***Delauney* creates a terrain database of optimal, irregular triangular polygons. You can control polygon count and maximize terrain accuracy by creating more polygons in rough terrain areas and fewer polygons in flatter areas.**
- ***Terrain Culture Triangulation (TCT)* processes feature data with the terrain data. Features such as roads, rivers, and lakes become part of the terrain skin instead of lying on top of the terrain.**
- ***CAT (Continuous Adaptive Terrain)* allows terrain to morph smoothly from one LOD to another.**

For the Palo Alto project, select the Polymesh algorithm to produce a uniform, rectilinear grid of triangles.

To set triangle conversion preferences:



## Generating Batch Terrain With Features

### Creating Terrain Using Batch Processing

**Step 1** Select the Triangle tab to display the Triangle panel.

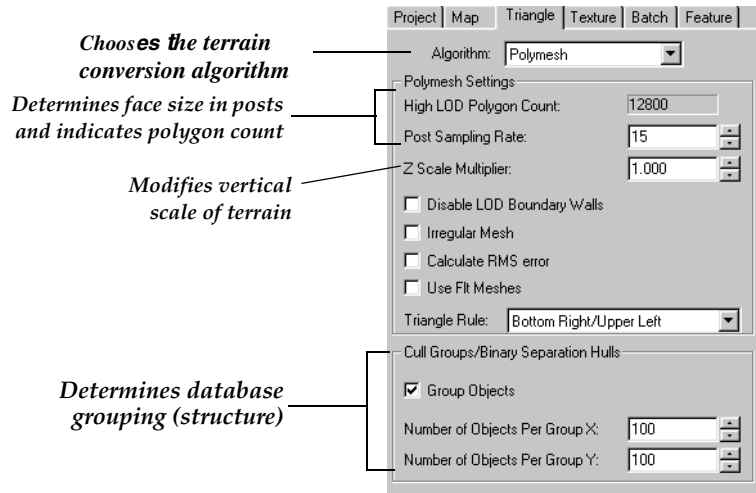

**Step 2** In the Algorithm field, choose Polymesh.

**Step 3** Enter 20 in the Post Sampling Rate field to create polygons from every 20th post at the most detailed LOD.

**Step 4** Set Group Objects and enter 100 in the *Number of Objects Per Group X* field and 100 in the *Number of Objects Per Group Y* field to organize the polygons into groups of 100x100 objects. Each object contains two polygons.



**Set Batch Area  
Block Preferences**

Batch processing uses area blocks that you select in the DED file. Area blocks are outlined in red when you activate the grid pattern in the Batch panel in the *Terrain* window. Area blocks are processed according to preferences that control their definition, selection, and processing.

To set batch area block preferences:

**Step 1** Select the **Batch** tab to display the **Batch** panel.

The screenshot shows the 'Batch' tab selected in the software interface. The panel contains the following settings:

- Batch Area Block Processing:**  Enable Area Block Processing
- Batch Local Origin:**  Use Local Origin,  Preserve Local Z
- Batch Area Shading:**  Calculate Shading
- Area Block Dimensions:**  Show Grid, Area Block Size in X: 120.000, Area Block Size in Y: 120.000, Units: Posts
- Area Block File Naming:**  Use Lower Left Lat/Long,  Prefix,  PrefixRow#Col# Format,  PrefixCol#Row# Format, 1st row: 0, 1st col: 0,  Overwrite Existing Filenames,  Make Portable Names
- Area Block Selection:** Select All, Deselect All, Read Select

**Step 2** Check the **Enable Area Block Processing** check box.

**Step 3** Check the **Show Grid** check box in the **Area Block Dimensions** section to display the area blocks outlined in red.



## Generating Batch Terrain With Features

### Creating Terrain Using Batch Processing

- Step 4** Ensure that *120* is the value in both the *Area Block Size in X* and *Area Block Size in Y* fields for 120x120 area blocks. This size also matches terrain polygon boundaries to eliminate partial groups.

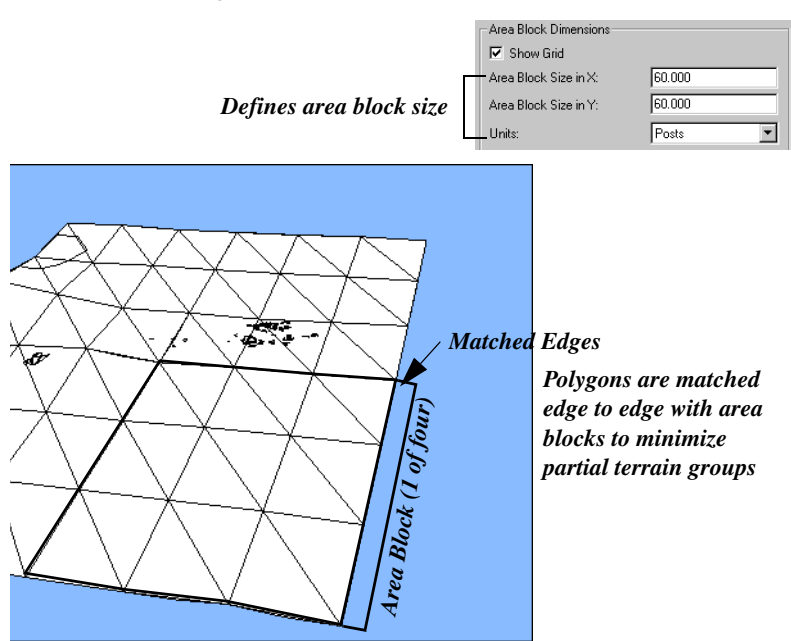

- Step 5** Ensure that *Posts* is the type of unit displayed in the Units field.
- Step 6** Batch terrain processing gives you several options for naming your area block files (see the figure below). For this exercise, set the Prefix option and type *PaloAlto* in the text field.

*In batch terrain processing, each area block is processed as a separate OpenFlight database*

*A master file is also produced which contains references to each of the files in the batch*

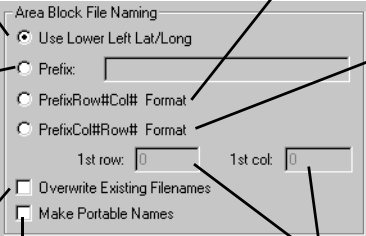

The screenshot shows a dialog box titled "Area Block File Naming" with the following options:

- Use Lower Left Lat/Long
- Prefix:
- PrefixRow#Col# Format
- PrefixCol#Row# Format
- 1st row:  1st col:
- Overwrite Existing Filenames
- Make Portable Names

Annotations for the dialog box:

- Each file takes its name from the actual lat/long coordinates of the area block's southwest corner* (points to "Use Lower Left Lat/Long")
- Each file takes its name from its row and column number in the grid* (points to "PrefixRow#Col# Format")
- Each file takes its name from its row and column number in the grid* (points to "PrefixCol#Row# Format")
- Each file takes its name from a user-defined prefix which is appended with a number* (points to "Prefix: - Overwrites existing files and reuses the file names if the batch process is run* (points to "Overwrite Existing Filenames")
- All file names are made lowercase, and spaces are converted to underscores (\_) so they can be ported to any system* (points to "Make Portable Names")
- Lets you specify the starting row and column number* (points to "1st row:



**Apply Terrain  
Textures to  
Elevations**

To give your terrain realism, you can assign different colors, materials, and textures to contours. A contour represents a range between any two elevations. When you select a contour from the elevation scale in the Contour Properties panel and select a texture from the Texture palette, for example, the texture is applied to all of the polygon faces in the corresponding range of elevations.

Surface textures will determine the colors for terrain areas in the Palo Alto project, so you only need to ensure that the correct textures are applied to the correct elevation bands. However, you can change the size of a contour by sliding the upper or lower boundary of an elevation up or down in the elevation scale.

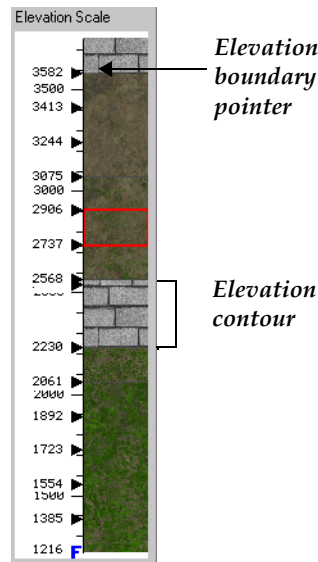

To apply textures to contours:

**Step 1** In the Contour Properties panel, select *Texture* from the Contour Properties pull-down menu.

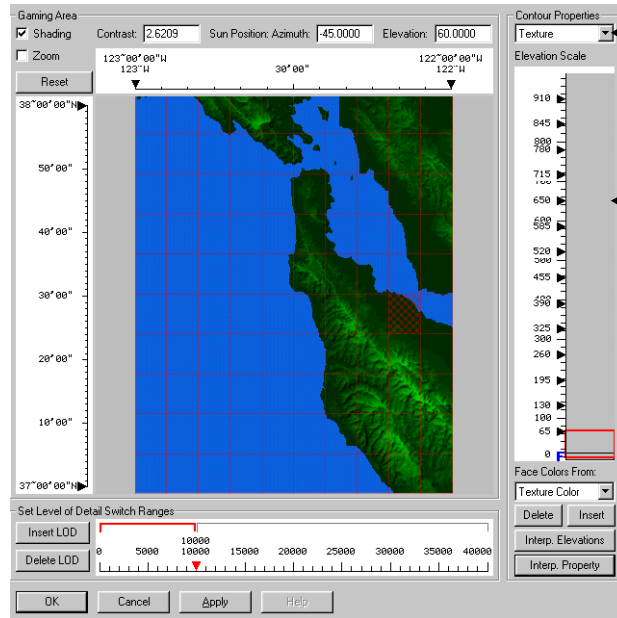

*Choose  
Texture*

*Displays the  
texture  
assigned to  
each eleva-  
tion*

**Step 2** Double-click a contour in the Elevation Scale to open the Texture Palette window.

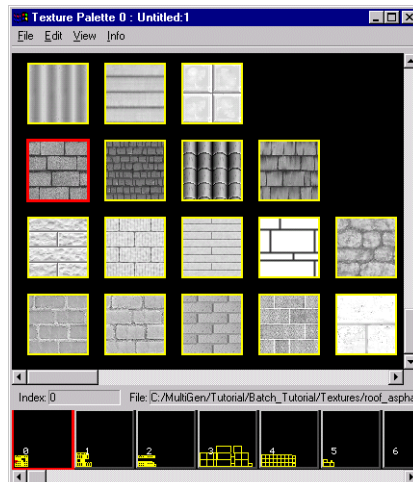

## Generating Batch Terrain With Features

### *Creating Terrain Using Batch Processing*

- Step 3** Select a texture. The item that you select in the palette is immediately assigned to the selected contour.
- Step 4** Close the *Texture Palette* window.
- Step 5** Select an elevation boundary pointer and slide it to a different elevation in the Elevation Scale. The Gaming Area updates to reflect the change. Press the Interp. Elevations button to reset the default settings.

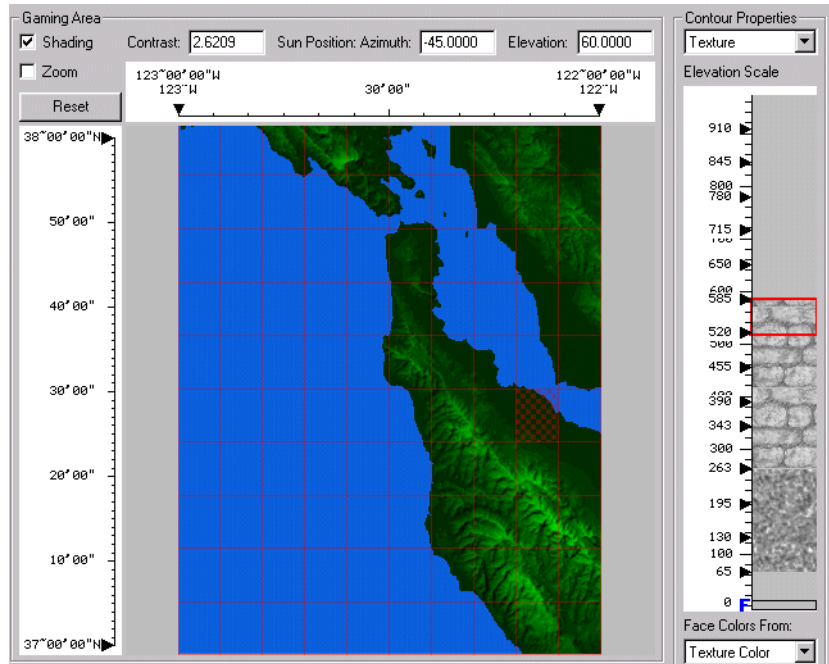

## Enter Levels of Detail Parameters

Levels of Detail (LODs) are versions of models that represent the same object in the database using different numbers of polygons. Model versions with a greater number of polygons display closest to the viewer while the lowest polygon versions display farthest away from the viewer. This structure optimizes a visual scene for drawing.

LOD switch ranges are the distances from the eyepoint to the center of the model at which an LOD model is displayed. LOD switch ranges are set in the LOD panel at the bottom of the *Terrain* window. The LODs are already set for the Palo Alto project.

If you want to change an LOD switch range, click the Insert LOD button to add an LOD switch-in pointer, and then slide the pointer to a switching distance. The number of generated LODs is one more than the number of pointers, which is also the total number of brackets at the top of the LOD panel. One pointer generates two LODs and three pointers generate four LODs, for example.

For this project, three LODs are assigned at 0-10,000 meters, 10,000-20,000 meters, and 20,000 meters to infinity. The terrain and relevant models are automatically generated for each LOD.

### Set Level of Detail Switch Ranges

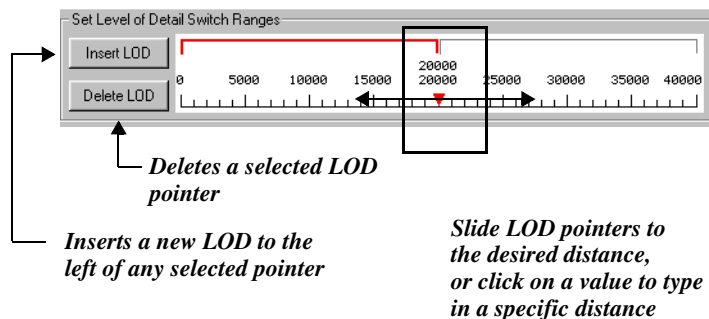

## Setting up Features

Feature data, or culture data, consists of all parts of the database that are not terrain skin polygons. These features can be natural, such as lakes and rivers, or man-made features, such as houses and roads.



Feature data originates from sources such as USGS, NIMA, or is created in MultiGen Creator and other 3D modeling tools. Feature data that originates from other sources is first converted to the Creator Digital Feature Data (DFD) file format before it is imported into Creator.

### **Load Feature Data to Project**

When you add cultural features to the terrain database in batch mode, the features are automatically extracted from DFD files and projected into the database. *Feature projection* is transferring 2D coordinates of the feature data that is in the DFD file to corresponding locations in  $x,y,z$  3D space. Each DFD file contains information about each feature, such as the feature's ID code (FID code), the area that the feature covers, and the feature's height.

In this exercise you will load the *village.dfd* file that was previously created into Creator to project features into the terrain database.

To load feature data to project:

**Step 1** Select the **Feature** tab to display the **Feature** panel.

#### Feature Panel

*Feature File:*  
*level0.dfd*

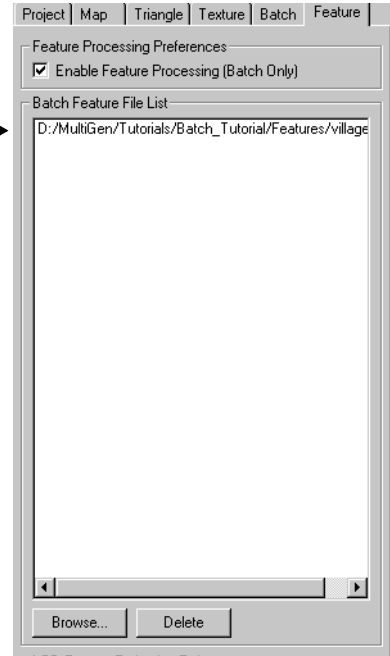

**Step 2** Ensure that the **Enable Feature Processing (Batch Only)** check box is checked. The Enable Feature Processing feature allows culture extraction from the DFD file during block processing.

The Enable Feature Processing feature is available only when the **Enable Area Block Processing** check box in the Batch panel is checked.

**Step 3** If a feature DFD file other than *village.dfd* is listed in the Batch Feature File area, select the file and click the Delete button.

**Step 4** Click the Browse button to open the *Choose Files for Culture Projection* dialog box.

**Step 5** Locate the *village.dfd* file and click the Open button. For Windows the file is in the `\Program Files\Multigen-Paradigm\resources\tutorials\creator\DesktopTutor\Batch_Tut`



## Generating Batch Terrain With Features

### *Creating Terrain Using Batch Processing*

*orial\Features (Windows) or the /usr/local/MultiGen-Paradigm/  
resources/tutorials/creator/DesktopTutor/Batch\_Tutorial/  
Features (IRIX) directory.*

#### **Load Feature Preferences**

Feature preferences control how features in the DFD are projected into the database. A building, for example, can be projected as either a flat or raised object on the terrain. MultiGen Creator projects the 2D coordinates of the feature data that is in the DFD file to corresponding locations in  $x,y,z$  3D space to create 3D wireframe volumes. Creator applies color, textures, materials, or library substitution models to these 3D wireframe objects based on the preferences that you save in the feature preferences file and rules and actions saved in the rules and actions preferences file. The default names for these files are *dfad.prefs* and *dfadbat1.prefs*, respectively, and they are saved to the Creator directory. But you can assign more meaningful file names as long as they have the *.prefs* suffix, and place them in any directory you wish. You load both of these files in the Project panel in the *Terrain* window.

For this project, the feature preferences file was created for you. You can view the settings in the file to see how the file was created.



To load feature preferences:

- Step 1** Click the **Project** tab to display the **Project** panel.
- Step 2** In the **GeoFeature Preferences** section, click the button next to the **Feature Preference** field to open the *Choose DFAD Preferences File* dialog box.

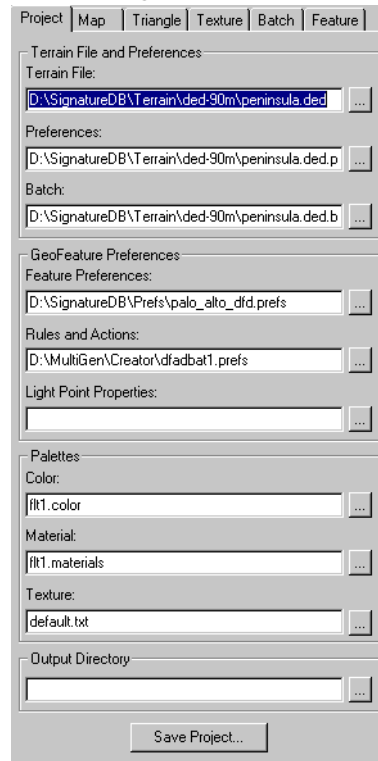

- Step 3** Locate the file *palo\_alto\_dfd.prefs* in the *\Program Files\Multigen-Paradigm\resources\tutorials\creator\DesktopTutor\DesktopTutor\Batch\_Tutorial\Prefs (Windows)* or the */usr/local/MultiGen-Paradigm/resources/tutorials/creator/DesktopTutor/ Batch\_Tutorial/Prefs (IRIX)* directory, and click **Open**.



# Generating Batch Terrain With Features

## Creating Terrain Using Batch Processing

To view the *dfad.prefs* file:

- Step 1** Drag the Terrain window down so that you can see the application window's menu bar.
- Step 2** Choose GeoFeature/Feature Preferences in the *Creator* window to open the *Feature Preferences* window with the *palo\_alto\_dfd.prefs* file that you previously loaded.

Features in DFD  
with feature IDs

Materials for  
current feature  
with material IDs

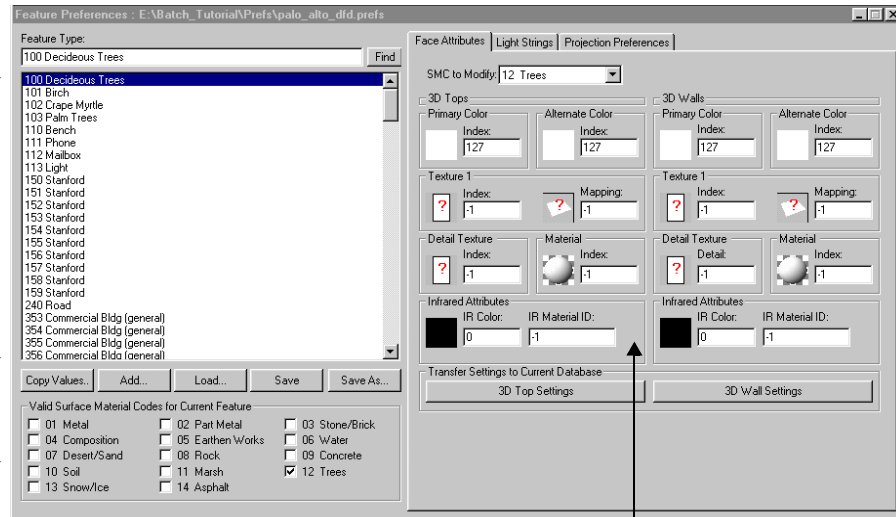

Settings, including attributes  
and preferences

- Step 3** Close the *Feature Preferences* window.



## **Load Rules and Actions**

MultiGen Creator requires a set of feature rules and actions to control the automatic extraction and projection of features onto the terrain. **Actions** extract sets of related point, linear, and areal features, such as forests, lakes, and roads, as well as projection preferences from DFD files. Actions can also apply library substitutions. **Rules** are sets of actions that determine the type and culture for each level of detail (LOD). Rules can contain more than one action and are necessary because only one rule can be applied to each LOD.

By default, the rules and actions as well as the LOD rule selections are saved in the *dfadbat1.prefs* file. For this project, the rules and actions file, *tutorial\_rule.prefs*, was already created, but you can view the rules and actions in the file to see how the file was created after you load the *tutorial\_rule.prefs* file in the Project panel. You will also associate a rule with the an LOD in the Feature panel.



## Generating Batch Terrain With Features

### *Creating Terrain Using Batch Processing*

To load rules and actions:

- Step 1** In the Preferences section, click the button next to the **Rules and Actions** field to open the *Choose DFAD Batch Preferences file dialog box*.
- Step 2** Locate the *tutorial\_rule.prefs* file in the *\Program Files\Multigen-Paradigm\resources\tutorials\creator\DesktopTutor\Batch\_Tutorial\Prefs (Windows)* or the */usr/local/MultiGen-Paradigm/resources/tutorials/creator/DesktopTutor/Batch\_Tutorial/Prefs (IRIX)* directory, and click **Open**.

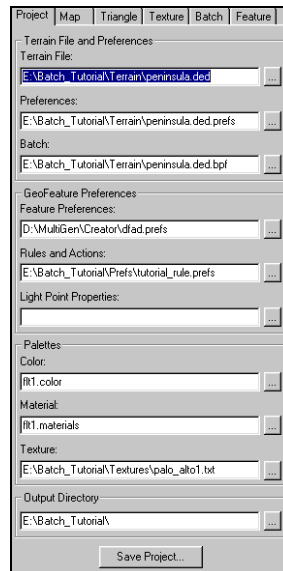

To view the *tutorial\_rule.prefs* file:

- Step 1** Drag the Terrain window down so that you can see the application window's menu bar.
- Step 2** Choose GeoFeature/Rules and Actions/Feature Actions in the *Creator* window to open the *Action List* window.
- Step 3** Click the Create button to open and view the *Action Definition* window.

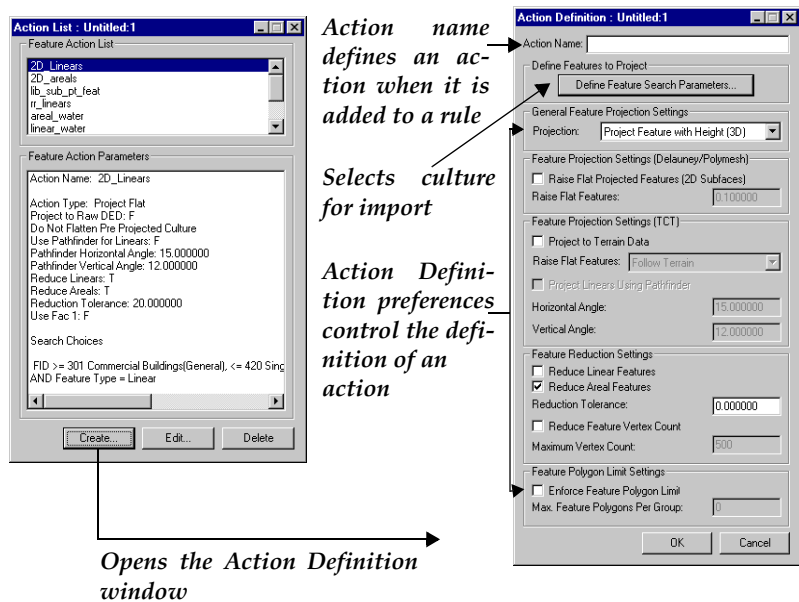

- Step 4** Close the *Action Definition* window.
- Step 5** Close the *Action List* window.



To associate a rule with an LOD:

**Step 1** In the Terrain window, select the Feature tab to display the Feature panel.

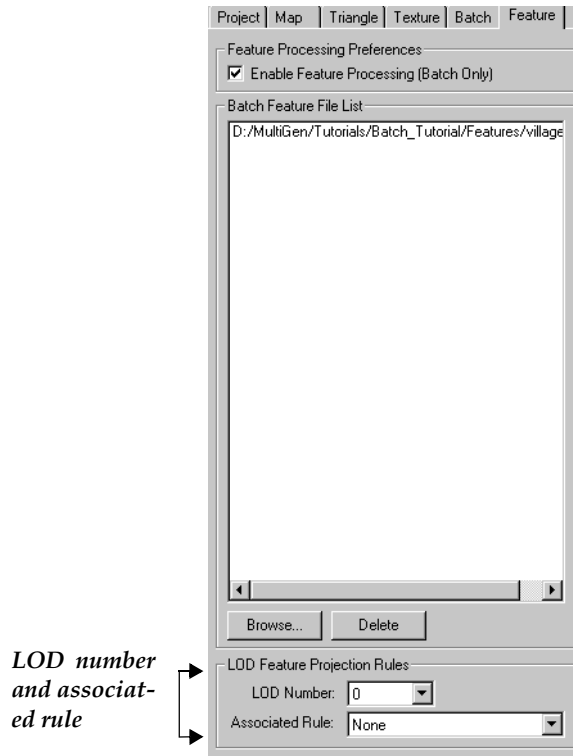

**Step 2** In the LOD Feature Projection Rules section, choose 0 for the LOD number in the LOD Number field. Select the *HiRule* rule for the LOD in the Associated Rule field.

**Step 3** Choose LOD Number 1 and select *LoRule* rule for the LOD in the Associated Rule field. *LoRule* has fewer associated actions.

## Set up Substitution Models

*Library substitution* replaces wireframe feature definitions that are in the DFD file with OpenFlight models. Models for buildings, bridges, and factories, for example, can be automatically substituted for wireframe features to make a terrain area visually appealing for low altitude fly-over zones or ground-based simulations.

Two sets of preferences control library substitution: **Projection preferences** and **Feature preferences**. **Projection preferences** specify a default directory for library models and determine if the models will be copied into the database during projection or inserted as external references. **Feature preferences** (Projection Preferences panel) determine the models that are available for library substitution for a feature type. If MultiGen Creator cannot find the model in the directory path that you specify in the *Feature Preferences* window, Creator looks in the default directory that you enter in the *Projection Preferences* window.

For this project, library models were already created and assigned to specific surface features. Indicate the path where the substitution models are found in the *Projection Preferences* window, and then view the library models assigned to feature types in the *Feature Preferences* window.



## Generating Batch Terrain With Features

### *Creating Terrain Using Batch Processing*

To set projection preferences:

**Step 1** Choose GeoFeature/Projection Preferences in the application window to open the *Projection Preferences* window.

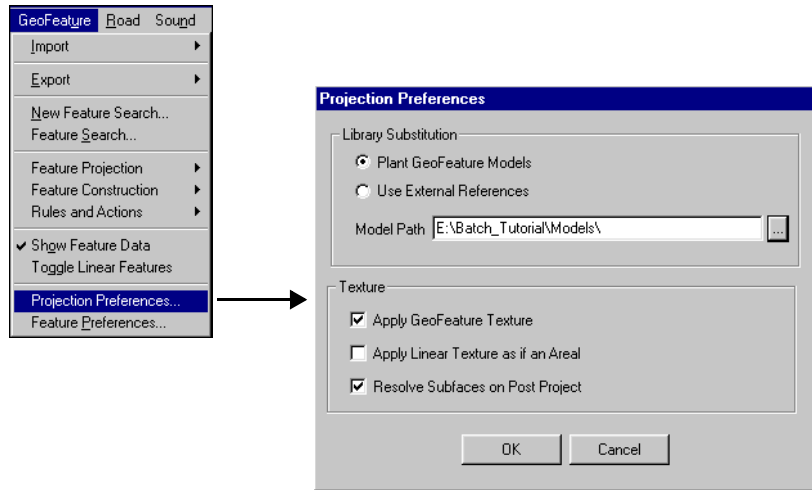

**Step 2** In the Library Substitution section, be sure the Use External References option is selected to create external references to the library models. External references require less memory than planting models in the database.

**Step 3** Click the button next to the Model Path field to browse for the *\Program Files\Multigen-Paradigm/resources/tutorials/creator\DesktopTutor\DesktopTutor\Batch\_Tutorial\Models (Windows)* or the */usr/local/MultiGen-Paradigm/resources/tutorials/creator/DesktopTutor/ Batch\_Tutorial/Models (IRIX)* directory.

**Step 4** Click OK.



To view library models:

**Step 1** Choose GeoFeature/Feature Preferences in the *Creator* window to open the *Feature Preferences* window.

**Step 2** Select the Projection Preferences tab to display the Projection Preferences panel.

Selected feature type

Library model for selected feature type. Click the Add button to select library model.

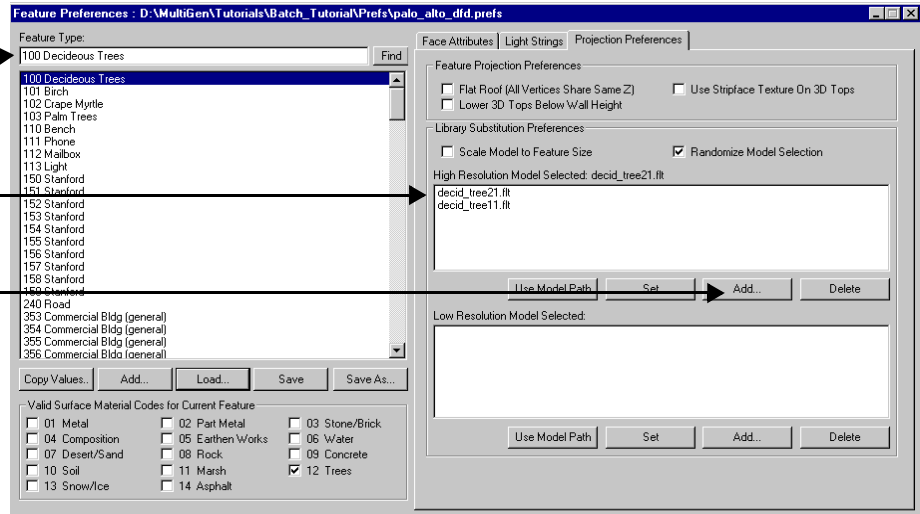

**Step 3** Select a feature from the list of feature types (for example, select FID ID 100). The library substitution files for the feature type are listed in the Projection Preferences panel.

You can substitute low resolution models in LODs that don't require a lot of detail, and high resolution models in LODs that do. For a more realistic effect, you can randomly substitute several models of the same feature type.

**Step 4** Close the *Feature Preferences* window.



**Select Area Blocks  
to Generate**

The Gaming Area section of the *Terrain* window contains a contour map of the imported data. You can select area blocks of terrain and features in the Gaming Area section to generate for your database. In the Palo Alto project, an area block that contains a small portion of downtown Palo Alto and the surrounding area should already be selected and shaded red.

To experiment, you can click an area block to the left or above the city to expand the area blocks. Each block that you select, however, adds some processing time. To deselect a shaded area block, click the area block again.

To select area blocks to generate:

**Step 1** In the Gaming Area, leave the area blocks that should already be selected and shaded red. These area blocks contain a small portion of downtown Palo Alto and the surrounding area.

**If you want to generate more terrain, select additional area blocks with the left mouse button.**

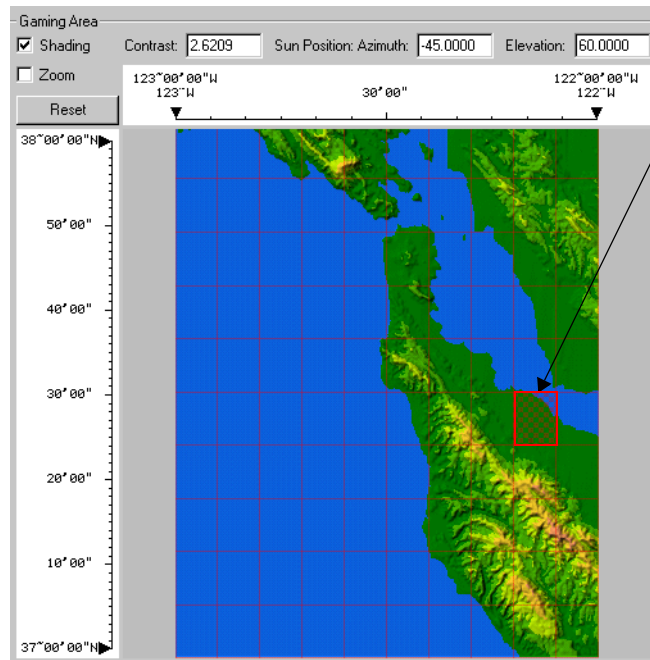

*Selected an area  
block to be processed*

**Step 2** Leave the *Terrain* window open.

---

**Note**

You should have write permission for all of your preferences files. Check that the *Read-Only* check box is unchecked in the MS Windows *Properties* window for each preferences file before you generate your terrain. To quickly check file permissions for the preferences files, click the button next to each path field in the Project panel, right-click on the preferences file that appears in the dialog box, and then choose *Properties* to open the *Properties* window.

---

**Create a Project File**

Now that you have chosen all your terrain generation and feature projection settings and loaded feature preferences and palette files, you should save your settings in a project file. This file, when loaded, automatically loads all the associated preference files and palettes specified in the Project panel. Project files can be loaded any time you want to use those settings, and you can use the settings in the them to create new project files.



## Generating Batch Terrain With Features

### *Creating Terrain Using Batch Processing*

To save a project file, click **Save Project** at the bottom of the Project panel. For this project, save the project file in the Batch\_Tutorial directory as *palo\_alto.prj*.

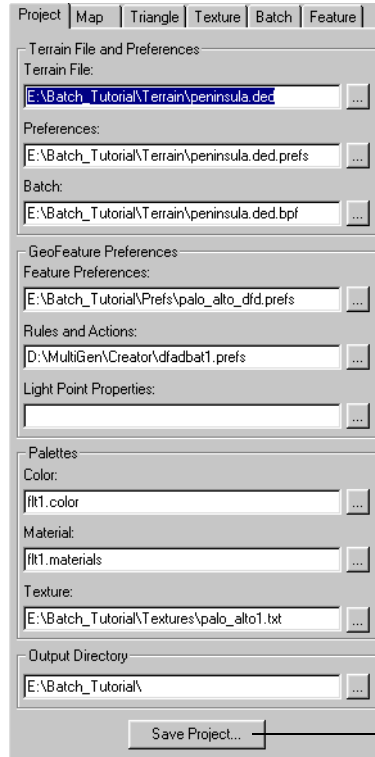

*Click to save your settings  
in a project file (\*.prj)*

## Generating the Terrain

You have completed all of the preparation work, and now you are ready to generate your new terrain and features.

As MultiGen Creator processes each area block, the area block highlights in the display. Processing is complete when the cursor returns to its normal state (an arrow), and the *Terrain* window disappears.

To generate terrain:

- Step 1** Click **OK** or **Apply** in the *Terrain* window to generate the new terrain. If you click the **Apply** button, the *Terrain* window stays open after the new terrain database is created, and you can later make any adjustments to your selections. If you click the **OK** button, the *Terrain* window automatically closes when the new terrain database is created.

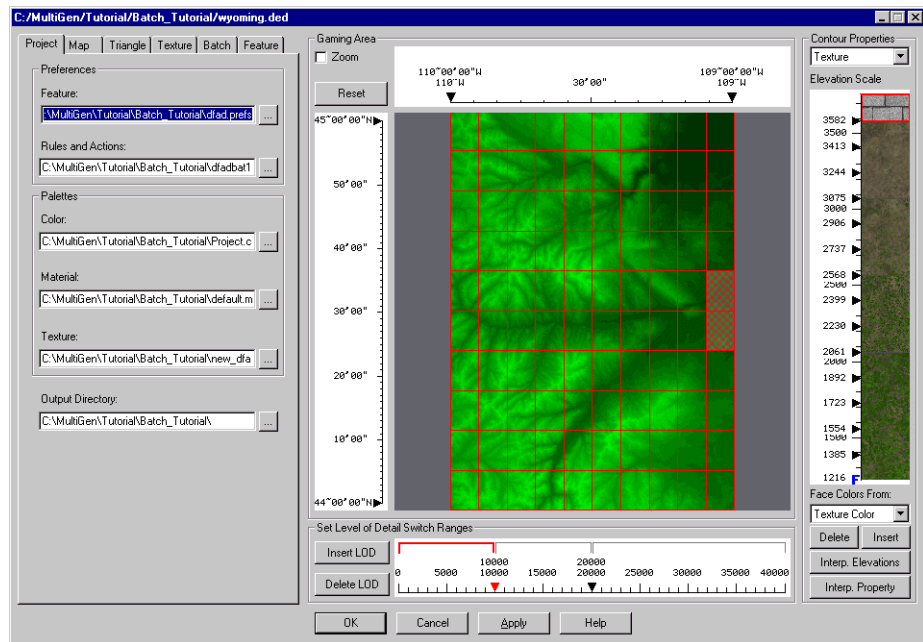

---

**Note**

When working on terrain, it is a good idea to close any large applications currently running on your system. Terrain data can be large and place demand on your system's memory capacity.

---

## Open the Master File

Behind the scenes, each area block is stored to disk as a separate flight file, for example, *PaloAlto1.flt*. A master flight file, such as *peninsula.flt*, is created and named after the original DED file. The master file contains external references to all area block files that make up the database. To see your new database, open the master file in the main *Creator* window.

To open the master file:

- Step 1** Choose File/Open in the main *Creator* window.
- Step 2** Select the master file *peninsula.flt* from the output directory, and click Open. The database appears in the *Creator* window.
- Step 3** If the terrain only partially displays, you must maximize the far clipping plane value by choosing View/Viewing Volume and sliding the Far Clipping Plane slider completely to the right in the *Viewing Volume* window.

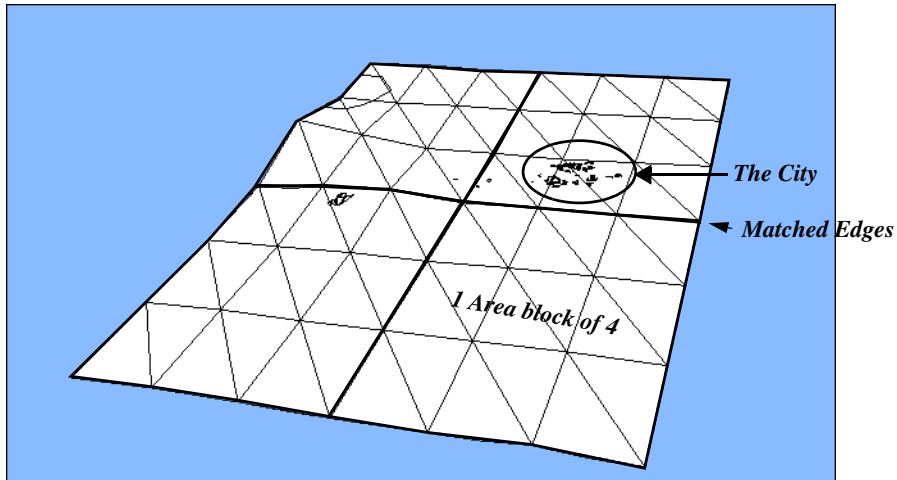

---

**Note**

If the city does not appear, try resetting the path for the DFD file in the Feature panel as described in “Load Feature Data to Project” on page 223.

---

**View the Low Resolution City**

For many high altitude or long-distance views in a database, flat features without textures can be used in less important areas. When you view the terrain at the lowest resolution LOD, all features are projected flat.

To view the low resolution city:

- Step 1** In the *Creator* window, choose LOD/Least Detail (Ctrl+Shift+L) to set your view of the terrain to the lowest resolution LOD.
- Step 2** Choose Face (Shft+F) in the toolbar to switch to Face mode, and press the Z key to turn on Z buffering if a Z is not already displayed in the top-left corner of the *Creator* window.
- Step 3** Select a feature in the city area.
- Step 4** Press the V key to zoom in, and press Shft+Right mouse to adjust your view to a comfortable distance.



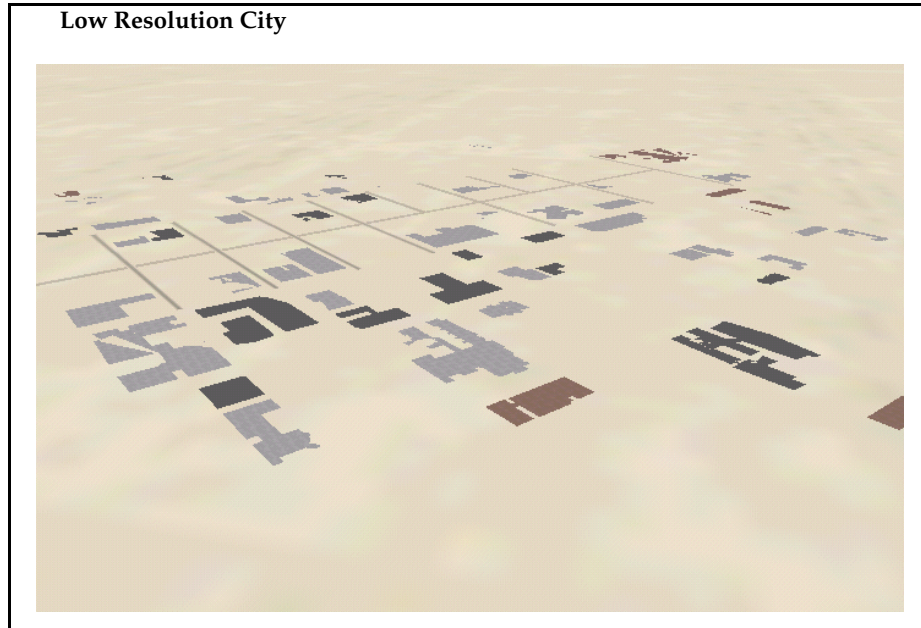

*From a high altitude, the low resolution, flat features appear normal.*

## **View the High Resolution City**

If your simulation is low flying over non-target terrain, basic visual cues are important. When you view the terrain at the highest resolution LOD and turn on textures, you can see large block buildings and areal forest blocks become textured according to their DFAD feature ID. Detailed substitution models are also visible, including individual point feature trees.

To view the high resolution city:

- Step 1** Choose LOD/Most Detail (Ctrl+Shift+M) to switch to the maximum LOD resolution.
- Step 2** Press the T key to turn on textures.

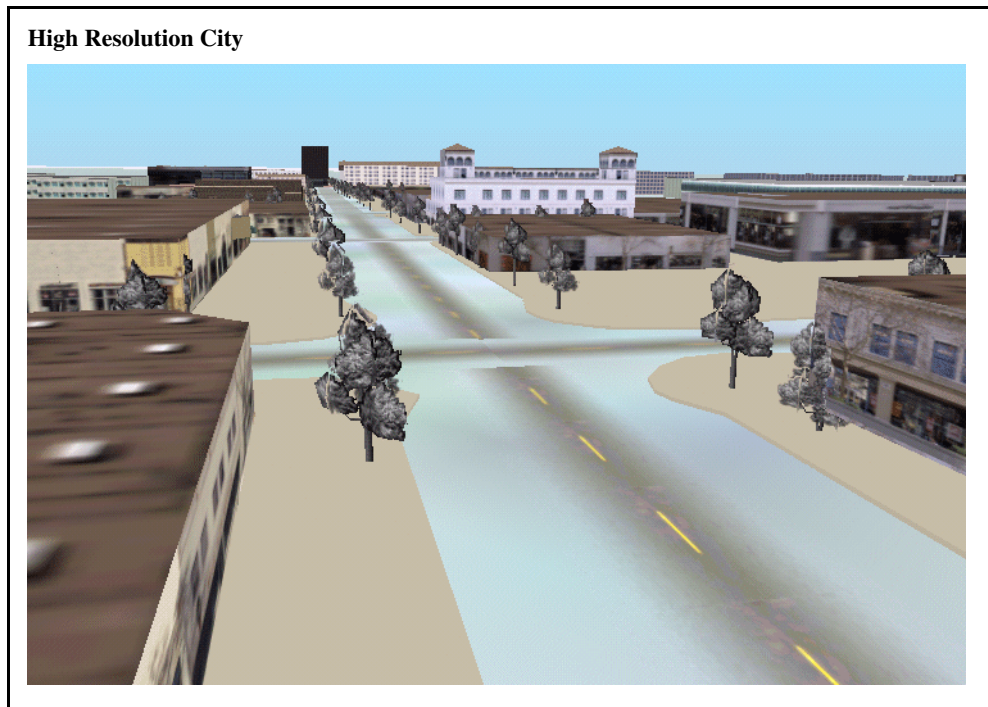

*From a low altitude, the high resolution, detailed features appear normal.*

## **Admire Your Work!**

You have now completed creating a terrain skin with projected features in one process using the batch processing option. For more information about batch processing, see *Creating Terrain for Simulations* or the online help.



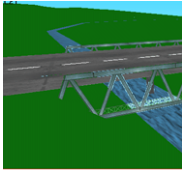

## Exploring TCT

### Introduction

The Terrain Culture Triangulation (TCT) terrain algorithm projects culture features directly to the elevation source data before terrain polygons are generated in batch mode. TCT stitches the terrain skin around the features so that features are correctly aligned with the finished terrain. This algorithm is useful for ensuring that roads and rivers are level while accurately following the elevation data and buildings lie flat without penetrating the terrain skin, for example. TCT also automatically places bridges where roads and railroad tracks cross bodies of water and creates intersections where roads cross each other.

This tutorial guides you through the process of importing an elevation file of an area in Wyoming with feature data and projecting a batch terrain with features to produce a complete OpenFlight database. The files that you will be using are in the Batch Tutorial directory that is also used in Chapter 11, “Creating Batch Terrain with Features.” Steps in this tutorial are described in more detail in Chapter 11.

<b>WHAT IS TCT?</b>	260
Terrain Tessellation	260
How TCT Works in Batch	260

<b>GENERATING A TCT DATABASE WITH CULTURE FEATURES</b>	262
Import the Terrain Data	262
Load Preference and Palette Files	264
Set Triangle Panel Preferences	265
Set Batch Area Block Preferences	266
Associate LOD Rules and Actions	267
View Rules and Actions	268
Generate the Terrain	269
Explore!	270

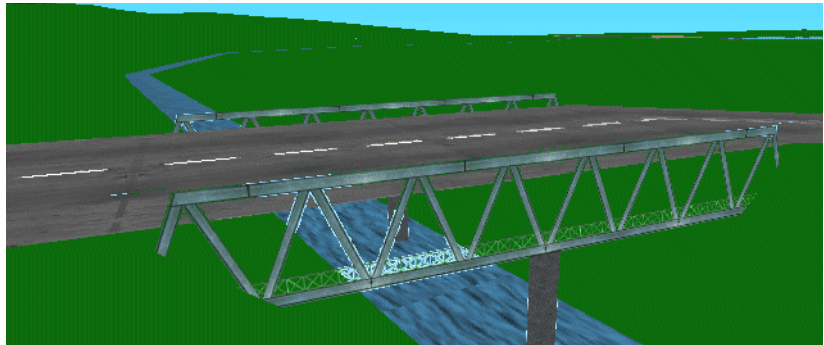

### What is TCT?

Terrain Culture Triangulation (TCT) uses a modified Delauney triangulation method. The Delauney method creates a terrain database with irregularly sized polygons to match the terrain surface they represent. Culture features such as lakes and valleys are drawn with higher accuracy than the terrain to maximize efficiency at runtime. TCT has the added feature of automatically generating intersections for overlapping objects. If a road is projected onto a river, for example, a bridge is placed where the road and river intersect.

Culture such as roads, rivers, lakes, and streams become a part of the terrain skin instead of lying on top of the terrain. With other types of triangulation methods, such as Polymesh and basic Delauney, features are post-projected after terrain is processed. TCT pre-projects features before creating the terrain skin, and both features and terrain are sewn together in efficient t-strips when the polygon database is created.

### Terrain Tessellation

The terrain is “stitched” between the pre-projected features and refined until the polygon budget or the error tolerance is reached. The terrain tessellation creates efficient terrain skin by using only the vertices of the constraints and terrain edges. If there is any remaining room in the polygon budget, vertices and additional polygons are added until either the error tolerance or polygon budget is met.

### How TCT Works in Batch

You select the TCT triangulation method in the Terrain window after you import a DED file into Creator. TCT works only in Batch mode. The Batch option processes individual terrain cells using rules and actions to give you full control over feature projection. *Actions* let you



control the projection of each DFAD feature ID (FID)/surface material code (SMC) combination; *Rules* are collections of actions applied together for automated feature processing.

The TCT process can be summarized in this way:

- **Features, including points, linears, and areals, are pre-projected using the DED file for elevation and accuracy in the order that you set in the rules and actions. TCT evaluates linear and areal culture to find intersections as well as overlapping or crossing culture and automatically resolves them.**
- **Terrain is stitched around pre-projected features.**
- **After the terrain is processed with pre-projected features, additional features can be post-projected onto the terrain using actions to control their order and placement.**

## Generating a TCT Database with Culture Features

The *peninsula.ded* file that you will import contains elevation data. You will also import feature files to integrate with the elevation data. After you choose the TCT conversion algorithm in the Terrain window and generate the terrain, you will notice that features are aligned correctly with the terrain and bridges are created where roads and rivers intersect.

To create a TCT terrain database triangulated with features:

### Import the Terrain Data

**Step 1** Choose Terrain/New Project. The *Open Terrain File* dialog box appears.

---

#### Note

If you created a project file in the Batch terrain exercise, choose Terrain/Open Project and open the *peninsula.prj* project file. All the files associated with the project will be automatically loaded. Skip to “Set Triangle Panel Preferences” on page 251.

---



# Exploring TCT

## Generating a TCT Database with Culture Features

**Step 2** Locate the *peninsula.ded* file in the `\Program Files\Multigen-Paradigm\resources\tutorials\creator\DesktopTutor\Batch_Tutorial\Terrain (Windows)` or the `usr/local/MultiGen-Paradigm/resources/tutorials/creator/DesktopTutor/Batch_Tutorial/Terrain (IRIX)` directory, and click Open. The *Terrain* window appears and displays the terrain that is in the DED file.

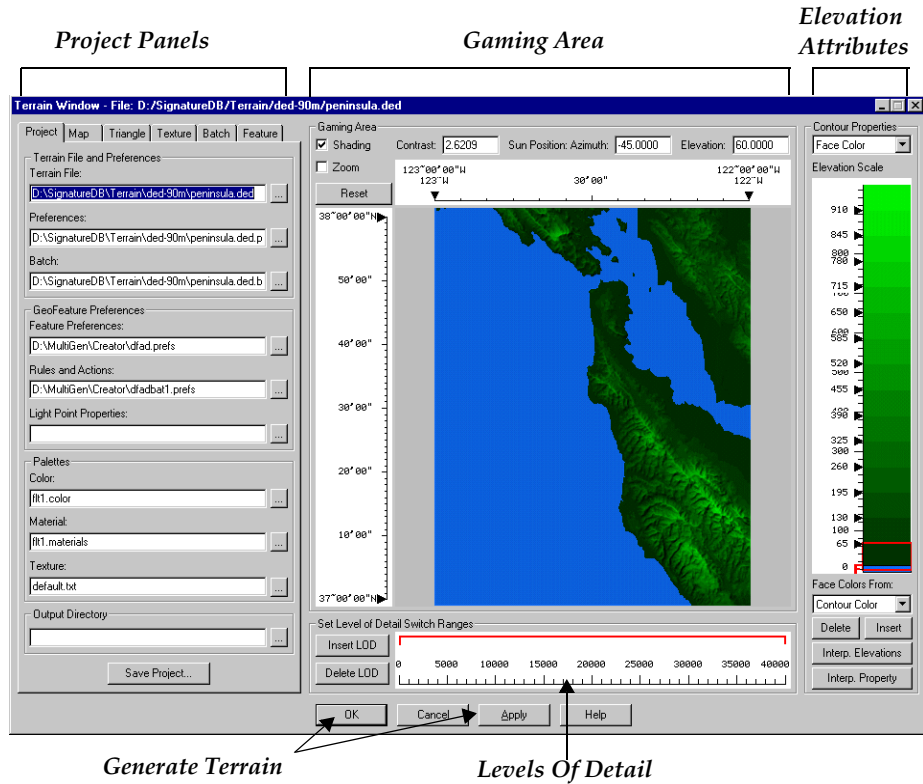

## Load Preference and Palette Files

**Step 1** Select the Project tab to display the Project panel.

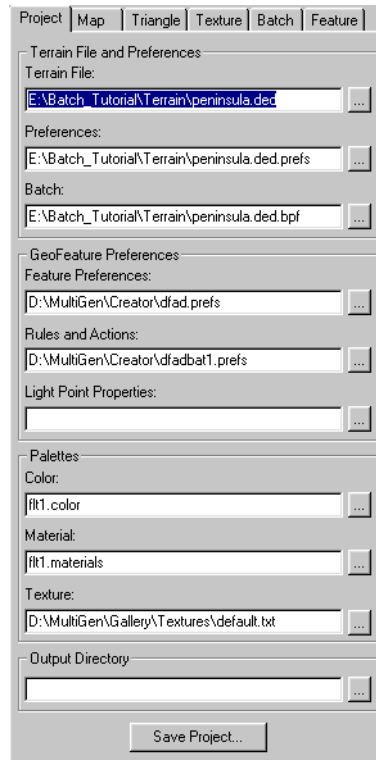

**Step 2** Set the path to the location of the feature preference file for features (`palo_alto_dfd.prefs`) in the Preferences region. This file is located in the `\Program Files\Multigen-Paradigm\resources\tutorials\creator\DesktopTutor\Batch_Tutorial\Prefs` (Windows) or the `/usr/local/MultiGen-Paradigm/creator/Tutorial_Files/Desktop_Tutor/Batch_Tutorial/Prefs` (IRIX) directory.

**Step 3** Set the path to the location of the preference file for rules and actions (`tutorial_rule.prefs`) in the Preferences region.

In the *Choose DEAD Batch Preferences* file window, change the value in the Files of type field to *All Files* to locate this file in the directory specified in Step 2..

**Step 4** Set the path to the location of the texture palette in the Palettes section. This file is located in the `\Program Files\Multigen-Paradigm\resources\tutorials\creator\DesktopTutor\Batch_Tu`



*tutorial\Textures (Windows) or the /usr/local/MultiGen-Paradigm/resources/tutorials/creator/DesktopTutor/ Batch\_Tutorial/Textures (IRIX) directory. For this exercise, we will use default color and material palettes.*

**Step 5** In the Output Directory section, enter the directory that you want the generated terrain files to be placed in. For this exercise, set the output directory to the *Batch\_Tutorial* directory.

## Set Triangle Panel Preferences

**Step 1** Click the Triangle tab to display the Triangle panel.

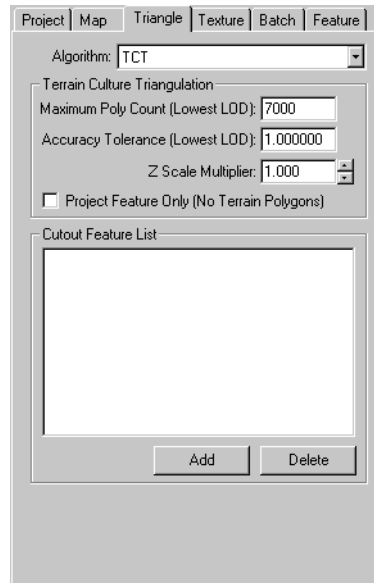

**Step 2** Choose *TCT* in the Algorithm field.

**Step 3** In the Terrain Culture Triangulation region, you can either set the maximum polygon count in the Maximum Poly Count (Lowest LOD) field and set the accuracy tolerance in the Accuracy Tolerance field, or leave the default settings.

*Maximum polygon count* sets the total number of polygons across the terrain surface. Polygons are added after the cultural features are processed until the maximum polygon count is reached.

*Accuracy tolerance* calculates the Z distance (for elevation) to all posts above and below a triangle. If the distance is greater than the accuracy tolerance value, the polygon is broken up

into more polygons to create a more accurate terrain skin. If the distance is less than the accuracy tolerance value, Creator stops triangulating.

## Set Batch Area Block Preferences

**Step 1** Click the Batch tab to display the Batch panel.

**Step 2** Check the Show Grid check box to display the grid in the Gaming Area.

**Step 3** Check that Area Block Size is 120 for both X and Y. This should already be set.

**Step 4** In the Area Block File Naming region, select a naming convention option for the new terrain databases.

Terrain databases can be named with the following conventions:

- The lower left latitude and longitude of the area block
- A prefix name that you specify
- A prefix of the area block row and column number
- A prefix of the area block column and row number.



## Associate LOD Rules and Actions

**Step 5** In the Gaming Area in the Creator Terrain window, leave the area block that should already be selected and shaded red. This area block contains a small section of downtown Palo Alto and the surrounding area.

**Step 1** In the LOD section of the Terrain window, click *Delete LOD* to delete any existing LODs. TCT only processes one LOD.

**Step 2** Click the Feature tab to display the Feature panel.

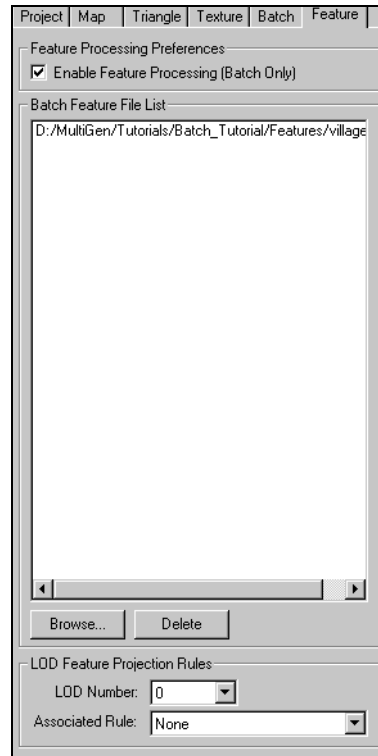

**Step 3** Ensure that the **Enable Feature Processing (Batch Only)** check box is checked. Feature processing only works in batch mode in Creator.

**Step 4** In the Batch Feature File List region, delete any files in the list by selecting them and clicking Delete.

**Step 5** Click **Browse** and choose *village.dfd* in the *\Program Files\Multigen-Paradigm\resources\tutorials\creator\DesktopTutor\Batch\_Tutorial\Features (Windows)* or the */usr/local/MultiGen-*

*Paradigm/resources/tutorials/creator/DesktopTutor/*  
*Batch\_Tutorial/Features (IRIX) directory. Feature data will be*  
**extracted from this file.**

**Step 6** In the LOD Feature Projection Rules section, choose *0* for the LOD number in the LOD Number field. TCT can only be used for one LOD at a time.

**Step 7** Select *TCT\_Rule* in the Associated Rule field to apply to the LOD.

## View Rules and Actions

To view the rules and actions associated with the LOD:

**Step 1** Drag the Terrain window down far enough that you can access the application window menu bar.

**Step 1** In the Creator menu, choose *GeoFeature/Rules and Actions/Rule List* to open the *LOD Rule List* window. This window lists all the rules defined in the Rules and Actions file (*tutorial\_rule.prefs*).

**Step 2** Select *TCT\_Rule* to display all the actions associated with it.

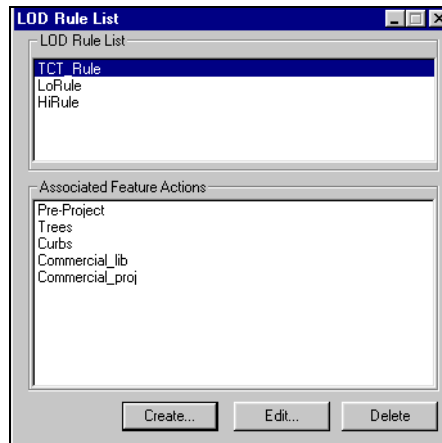

**Step 3** Choose *GeoFeature/Rules and Actions/Feature Actions* to open the *Action List* window.

**Step 4** Click the action *Pre Project* and then click *Edit* to open the *Action Modify* dialog box.



**Step 5** In the Feature Projection Settings for TCT, set the Project to Terrain Data checkbox, and set Raise Flat Features to Follow Terrain. By setting these options, Creator will pre-project any features that satisfy the search parameters (in this case, 240 roads) and then build the terrain around the features.

**Step 6** Leave Project Linears Using Pathfinder unset. Setting this option creates roads that are drivable using the Road/Drive Road feature. However, because it also creates more polygons, it should only be used when your simulation requires a drivable road.

**Step 7** Click OK to close the *Action Modify* dialog box. Close the *Action List* window and the *LOD Rule List* window.

## Generate the Terrain

**Step 1** At the bottom of the Terrain window, click OK to process the terrain and close the Terrain window, or Apply to process the terrain and leave the Terrain window open.

A master file `peninsula.flt` (or `peninsulav1.flt`, if you already generated terrain in the batch exercise) is created that references all of the terrain tiles processed in batch mode.

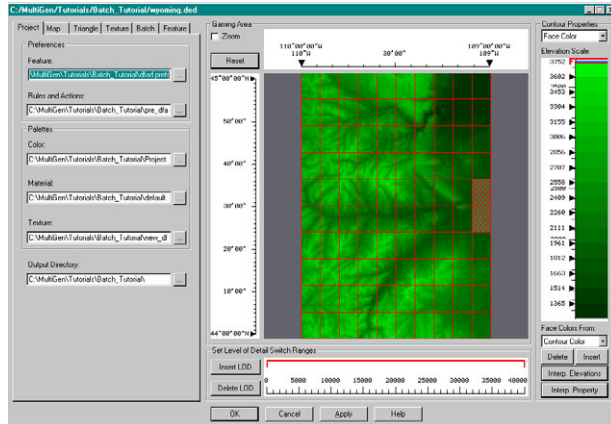

**Step 2** Choose File/Open in the main *Creator* window.

**Step 3** Select the master file `peninsula.flt` (or `peninsulav1.flt`), and click Open. The database appears in the *Creator* window.

**Step 4** Press the T key to turn on textures.

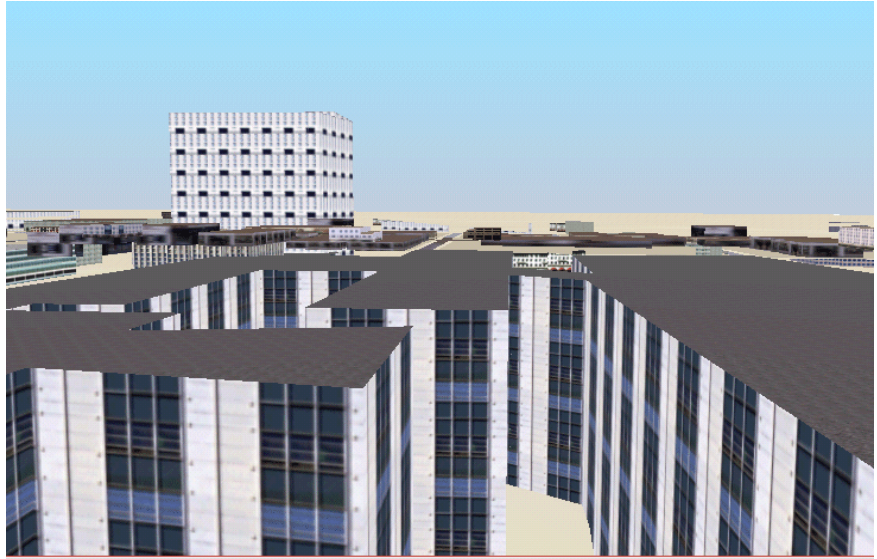

### **Explore!**

Take a look at different features, such as streets and buildings, around the database. It is easy to see how terrain databases can be made with carefully defined rules and actions to process features with TCT. For more information about the TCT algorithm, see *Creating Terrain for Simulations* or the online help.

